

Virginia Aviation Board
Meeting Agenda
Thursday, June 17, 2021

The Virginia Aviation Board will hold a meeting at 10:00 a.m., Thursday, June 17, 2021 at the Virginia Department of Aviation, Passenger Terminal Hangar, 5702 Gulfstream Road, Richmond, VA 23250. The meeting is available through webex: <https://covaconf.webex.com/covaconf/onstage/g.php?MTID=e9e94cc0479c40fb9099ec5dc6a90c1d4> or by calling 1-517-466-2023 with access code: 161 060 5356

Following CDC guidelines and the Governor's guidance, individuals considered fully vaccinated are not required to wear face coverings. Face coverings are required for those not considered fully vaccinated.

- | | | |
|--|---|--------------|
| 1. Call to Order | Rod Hall, Chairman | (5 minutes) |
| 2. Review and approve March 18, 2021 minutes | Rod Hall, Chairman | (5 minutes) |
| 3. Recognition of Outgoing Board Member-Jack Kennedy | Rod Hall, Chairman | (5 minutes) |
| A. Jack Kennedy – Region 1 Board Member | | |
| B. Barbara Haxter – Accomack County Airport Manager | | |
| 4. Updates and Announcements: | | |
| A. Danville Airport Presentation | Marc Adelman,
Transportation
Services Director,
Danville | (15 minutes) |
| B. Civil Air Patrol & VABA Update | Col. Elizabeth
Sydow/CAP
Bud Oakey/VABA | (15 minutes) |
| C. DOAV Update | Mark Flynn
DOAV | (15 minutes) |
| 1. Advanced Air Mobility | | |
| 2. Sustainable Aviation Fuel | | |
| D. FAA-FSDO Update | Maury Dacey
FAA | (10 minutes) |
| E. VAOC Update | Keith Holt
VAOC | (10 minutes) |
| 5. Old Business | | |
| A. <i>Airport Program Manual</i> | Cliff Burnette/
Susan Simmers
DOAV | (30 minutes) |
| B. Airport Licensing Issues – Falwell Airport | Vernon Carter
DOAV | (5 minutes) |
| C. Commonwealth Aviation Fund Status | Cliff Burnette
DOAV | (5 minutes) |

D. Aviation Special Fund Status	Mark Flynn DOAV	(5 minutes)
6. New Business		
A. Virginia Air Transportation System (VATS) Plan Update	Cliff Burnette DOAV	(10 minutes)
B. Project Prioritization Process – <i>Airport Program Manual</i>	Mike Swain DOAV	(15 minutes)
C. VRA - Airports Bond Defeasance	Mike Swain DOAV	(5 minutes)
D. Consideration of Amended FY21 Entitlement Utilization Plans	Mike Swain DOAV	(10 minutes)
1. Charlottesville-Albemarle Airport		
2. Lynchburg Regional Airport		
3. Newport News/Williamsburg International Airport		
4. Shenandoah Valley Regional Airport		
E. Virginia Aviation Board Review Tentative Allocations from the Commonwealth Aviation Fund	Mike Swain DOAV	(15 minutes)
7. Public Comment Period (3 minutes per person to address the board)	Rod Hall, Chairman	
8. Board Member Comments and Reports	Rod Hall, Chairman	(5 minutes)
9. Adjournment	Rod Hall, Chairman	



Virginia Aviation Board Meeting

DOAV Passenger Terminal Building

Richmond, VA

June 17, 2021

Review & Approve Minutes

**March 18, 2021
Meeting**



Recognition of Outgoing Board Member

Jack Kennedy – Region 1



Danville Regional Airport Update Virginia Aviation Board Meeting

JUNE 17, 2021

Danville Regional Airport Update Airport Promotional Video

Funding provided through a Virginia Department of Aviation Promotion Grant

Danville Regional Airport Promotional Video

Airport video can be viewed at www.danvilleregionalairport.com

Danville Regional Airport Update Background Information

- CLASS E airspace
- Primary Runway 02/20, 5900' by 100', HIRL
- Precision ILS Runway 02
- GPS Runway 02
- Crosswind Runway 13/31, 3911' by 100', MIRL
- Crosswind Runway Blast Pad 908' by 100'
- GPS, Nonprecision Runway 31



Non-Controlled Advisory
Tower

Danville Regional Airport Update Background Information – Fees

- T-hangars: 30 units, sliding and bi-fold doors (**\$150** and **\$175**)
- Box hangars: 2 units (**\$300** per unit - 55' x 51')
- Corporate Hangars: 4 hangars, sliding and bi-fold (**\$740** for 65' x 60' and **\$1040** for 80' x 80')
- Personal Property Tax Rate on Aircraft (Inventory Bluebook value x **\$.30 per hundred**)

Danville Regional Airport Update Operational Highlights

- **Averett University's Aeronautics Program: primary user of the field – 108 students, 15 flight instructors, 11 aircraft in fleet (Primary Aircraft - Piper Archer, III, TX)**
- **Total Annual jet aircraft operations: 450 average (Primary - NETJETS, FLEXJET, Wheels Up)**
- **Primary generator of jet aircraft operations: The Virginia International Raceway (VIR)**
- **March 2021: 22,000 gallons of jet fuel sold in one weekend for a VIR race**
- **June 2021: 32 unduplicated jets accessed field for a VIR race, 23,000 gallons sold in one weekend**
- **On average, aviation fuel purchased annually - 60% Jet A and 40% AVGAS**

Danville Regional Airport Update

Total Aviation Fuel Purchased thru May (11-month period)

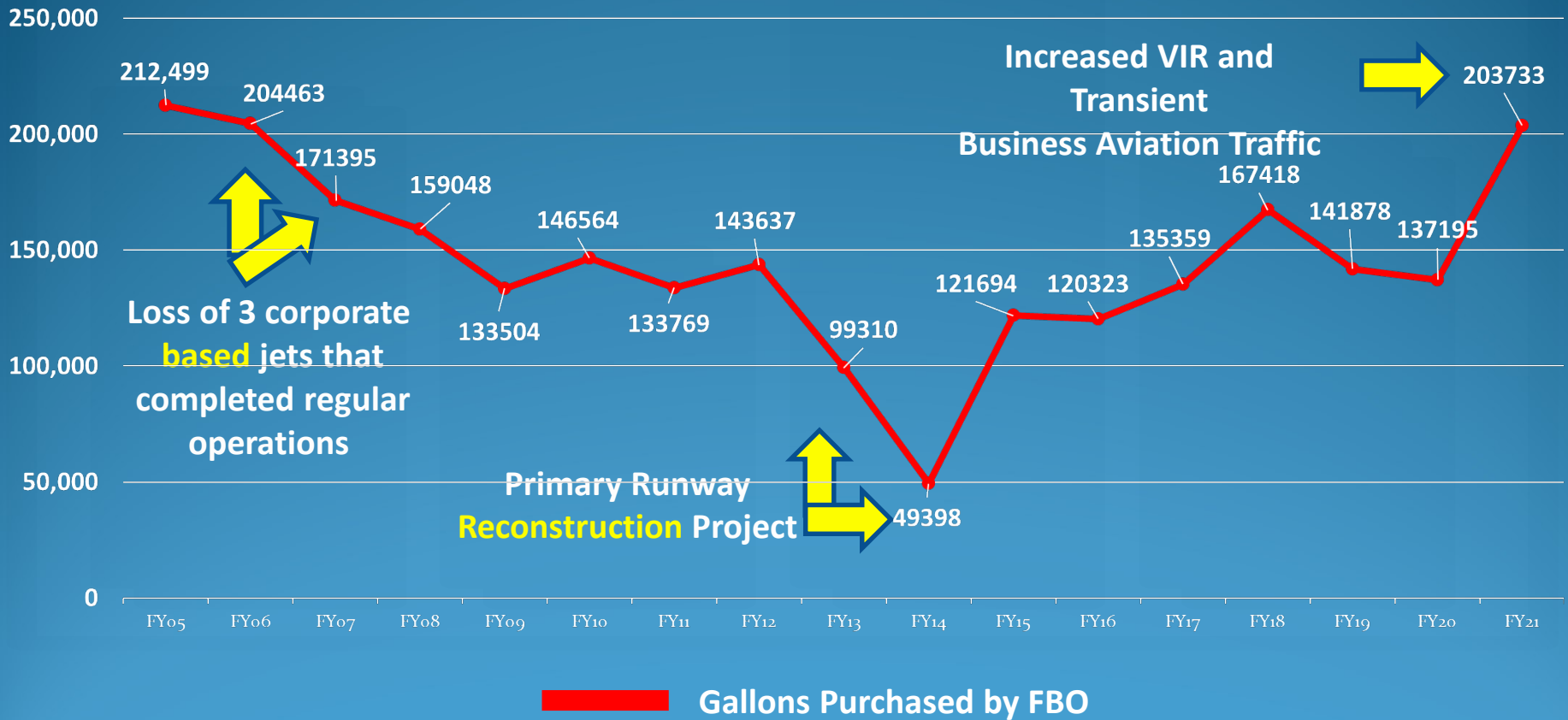

STATUS OF AIRPORT PROJECTS OVERVIEW – FY22 AND FY23

PROJECT 6

Fuel Farm Expansion

PROJECT 2

Terminal Building Renovations Architectural Services

Rehabilitate Runway 13/31 and Taxiway F

PROJECT 1

PROJECTS 3 & 4

Widen Taxiway H, Construct New Taxi-lane to support a new T-Hangar building and develop corporate aircraft ramp

PROJECT 5

Rehabilitate South Ramp and Taxiway Connections

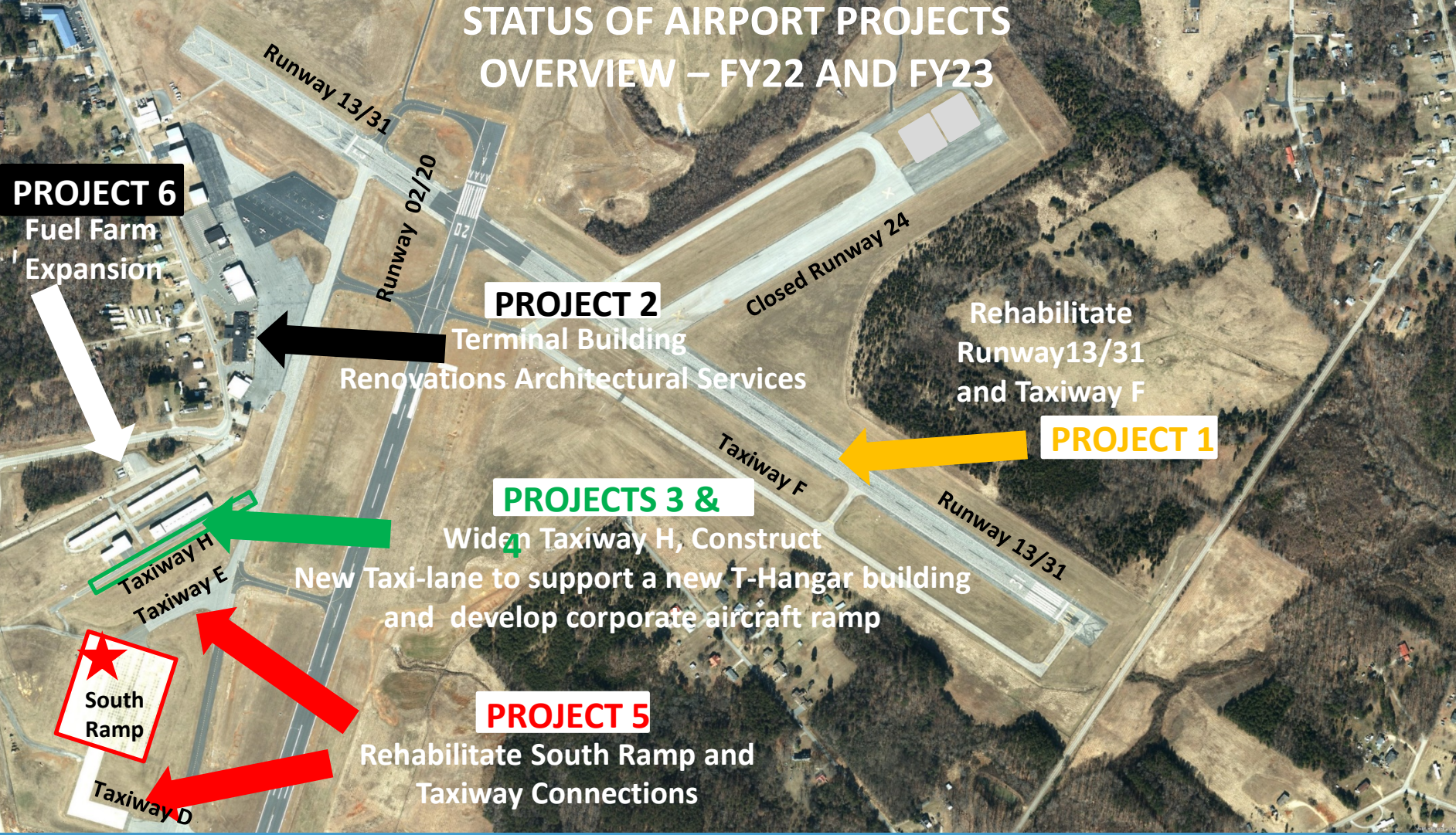

STATUS OF AIRPORT PROJECTS

PROJECT NUMBER	PROJECT NAME	PROJECT OBJECTIVE	PROJECT STATUS
1	REHABILITATE RUNWAY 13/31 AND TAXIWAY F – CONSTRUCTION	MILL 2”, INSTALL FABRIC AND PAVE – PRESERVE DANVILLE’S CROSSWIND RUNWAY	LOCALLY FUNDED PROJECT APPROVED FOR CITY’S FY22 BUDGET. CONSTRUCTION WORK IS EXPECTED TO BEGIN BY JULY 5, 2022
2	ARCHITECTURAL SERVICES TO RENOVATE TERMINAL BUILDING	IMPROVE ACCESS FROM AIRSIDE TO LANDSIDE AND EXPAND FACILITY AMENITIES FOR PILOTS AND PASSENGERS PROJECT WILL INCLUDE NEW FURNITURE FOR COMMON AREA AND PILOT’S LOUNGE	ARCHITECTURAL SERVICES CONTRACT HAS BEEN AWARDED. A KICKOFF MEETING WITH THE ARCHITECT AND REPRESENTATIVES OF THE AIRPORT COMMISSION AND AVERETT UNIVERSITY/NEW FBO WAS COMPLETED ON JUNE 8 TH PLANNED IMPROVEMENTS BASED ON REVIEW OF FBO FACILITIES LOCATED AT RDU.
3	WIDEN TAXIWAY H BY 25’ – CONSTRUCTION	WIDEN TAXIWAY TO SUPPORT CORPORATE JET AIRCRAFT OPERATIONS, CONSTRUCT TAXILANE AND SITE PREP FOR NEW T-HANGAR BUILDING	CONSTRUCTION WORK IS NOT EXPECTED TO BEGIN UNTIL SEPTEMBER 2021

STATUS OF AIRPORT CAPITAL PROJECTS

PROJECT NUMBER	PROJECT NAME	PROJECT OBJECTIVE	PROJECT STATUS
4	DESIGN SERVICES TO CONSTRUCT JET AIRCRAFT PARKING RAMP 375' X 23' AND AUTOMOBILE PARKING LOT	<p>COMPLETE DESIGN SERVICES TO BID PROJECT THIS FALL TO CONSTRUCT AIRCRAFT RAMP FOR JETS AND 39-SPACE AUTOMOBILE PARKING LOT</p> <p style="text-align: center;">SUPPORT DEVELOPMENT OF PUBLIC USE CORPORATE HANGARS</p>	GRANT APPLICATION SUBMITTED TO COMPLETE DESIGN SERVICES TO THE VIRGINIA DEPARTMENT OF AVIATION
5	DESIGN SERVICES TO REHAB TAXIWAY CONNECTIONS AND SOUTH RAMP	<p style="text-align: center;">ALLOW FOR USE OF SOUTH RAMP TO SUPPORT BUSINESS AVIATION DEVELOPMENT AND SUPPORT POSSIBLE SURPLUS AIRCRAFT PARKING NEEDS</p>	<p>FUNDING WAS APPROVED IN MAY 2021 BY THE FAA TO COMPLETE DESIGN SERVICES TO BID THE PROJECT</p> <p>BIDS WILL BE OPENED DURING THE SPRING OF 2022</p>
6	DESIGN SERVICES FOR FUEL FARM EXPANSION	<p style="text-align: center;">INCREASE FUEL SUPPLY TO SUPPORT JET AIRCRAFT OPERATIONS RELATED TO THE OPENING OF THE CAESAR'S CASINO</p>	GRANT APPLICATION TO BE SUBMITTED FOR NOVEMBER 2021 VIRGINIA AVIATION BOARD MEETING

PROJECT NAME	PROJECT OBJECTIVE	PROJECT STATUS
2021 AIRPORT OPEN HOUSE AND YOUNG EAGLES RALLY	IMPROVE AVIATION AWARENESS , AND THE PUBLIC'S UNDERSTANDING OF THE AIRPORT'S LINK WITH THE COMMUNITY	EVENT SCHEDULED FOR SEPTEMBER 11th WITH RAIN DATE PLANNED FOR OCTOBER 30, 2021

**AIRPORT OPEN HOUSE/ YOUNG EAGLES RALLY
EVENT ACTIVITIES**

- Free flights for children. Assistance provided by the Apex, North Carolina EAA 1114 Chapter and local pilots.
- Tours completed of Averett University's Flight Center Building, the Operations Advisory Tower and the Civil Air Patrol Building
- Danville Science Center Exhibit Activity
- Free Refreshments for the public (Pizza, Cookies)



STATUS OF AIRPORT PROJECTS

Taxiway H Widening Project

LEGEND

Black Text - Construction,
Approved Grant

Red Text - Design
Services, Grant
Requested and
*T-hangar building to be
constructed by 2022*

39-Space
Automobile
Parking Lot

13,000 square foot hangar
100' wide x 130' long

Retaining wall
required

[Hangar Development Video](#)

Taxiway
Widening

Jet Aircraft Parking

Aircraft Parking

New Taxi-lane

New T-Hangar Building

LEGEND	
TAXIWAY 'H' WIDENING (AIP)	
HANGAR APRON (NON-AIP)	
T-HANGAR TAXILANE (AIP)	
T-HANGAR APRON (NON-AIP)	
CORPORATE HANGAR, ACCESS RD & PARKING (NON-AIP)	

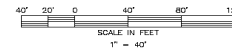

**PRELIMINARY
NOT RELEASED
FOR CONSTRUCTION**

**TALBERT, BRIGHT
& ELLINGTON**
ENGINEERING & PLANNING CONSULTANTS
3015 WHITEHALL PARK DRIVE, SUITE 100
CHARLOTTE, NORTH CAROLINA 28278
PHONE: 704-535-6819 FAX: 704-535-6888
OPOR 0407006503

DESIGNED BY:	PROJECT ENG. CBS	DATE	
DRAWN BY:	PROJECT NO.	REVISIONS	
CHECKED BY:	DRAWN BY: BBV	1	
DATE ISSUED: MAY 2020		2	
		3	
		4	
		5	

DANVILLE
—Regional—
DANVILLE REGIONAL AIRPORT

TAXIWAY 'H' WIDENING AND
HANGAR DEVELOPMENT
4 UNIT T-HANGAR AND 1 BOX HANGAR EXHIBIT
FILE NAME: SCALE: 1"=40'

SHT. **1**

STATUS OF AIRPORT PROJECTS

Current plans call for completing **design services** to rehab the south ramp by December 2021 and then complete construction activities to rehab at least half of the south ramp (Phase 1) during FY22 and then rehab the second half of the south ramp (Phase 2) during FY23 dependent upon available federal aid.

It is anticipated that the south ramp may be needed for surplus aircraft parking when major VIR race weekends **overlap** with casino traffic activity.

66,300
Square feet

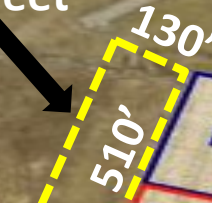

Asphalt buckling

Concrete cracking - ASR

Asphalt buckling

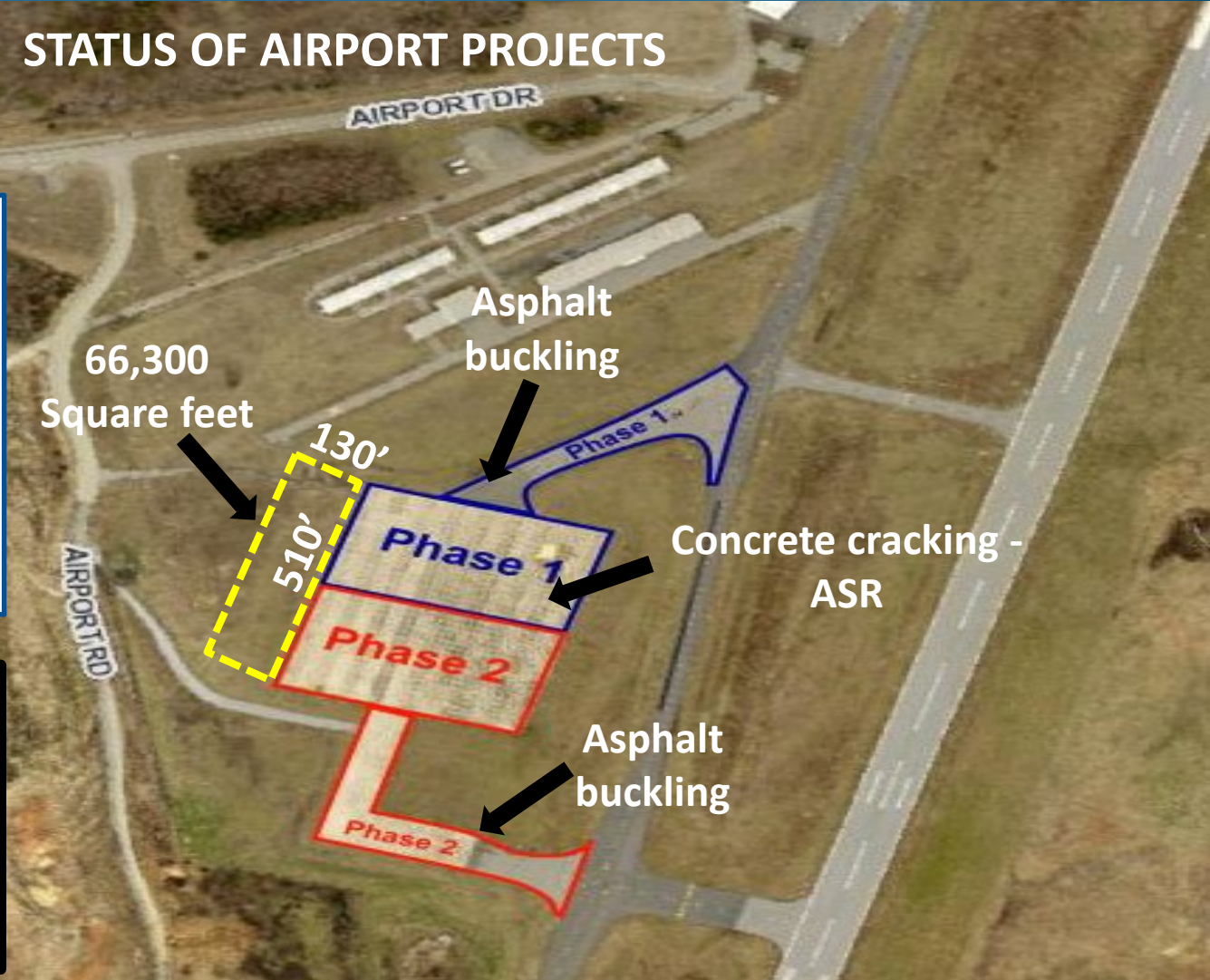

STATUS OF AIRPORT CAPITAL IMPROVEMENT PROJECTS

Terminal Building Renovations

LANDSIDE
Airport Drive

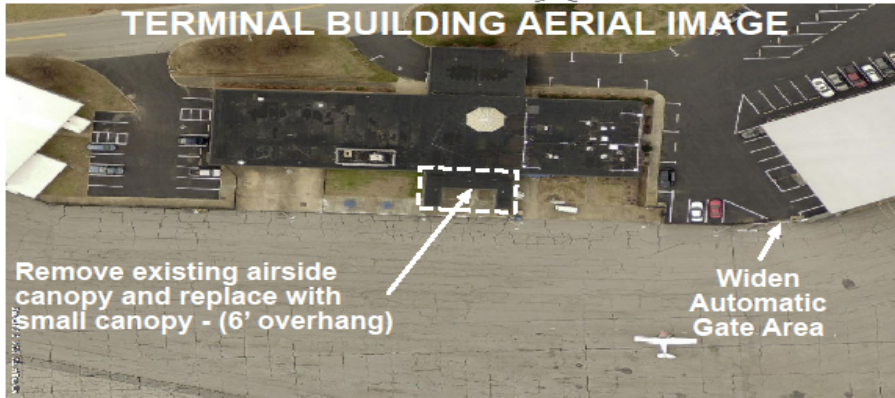
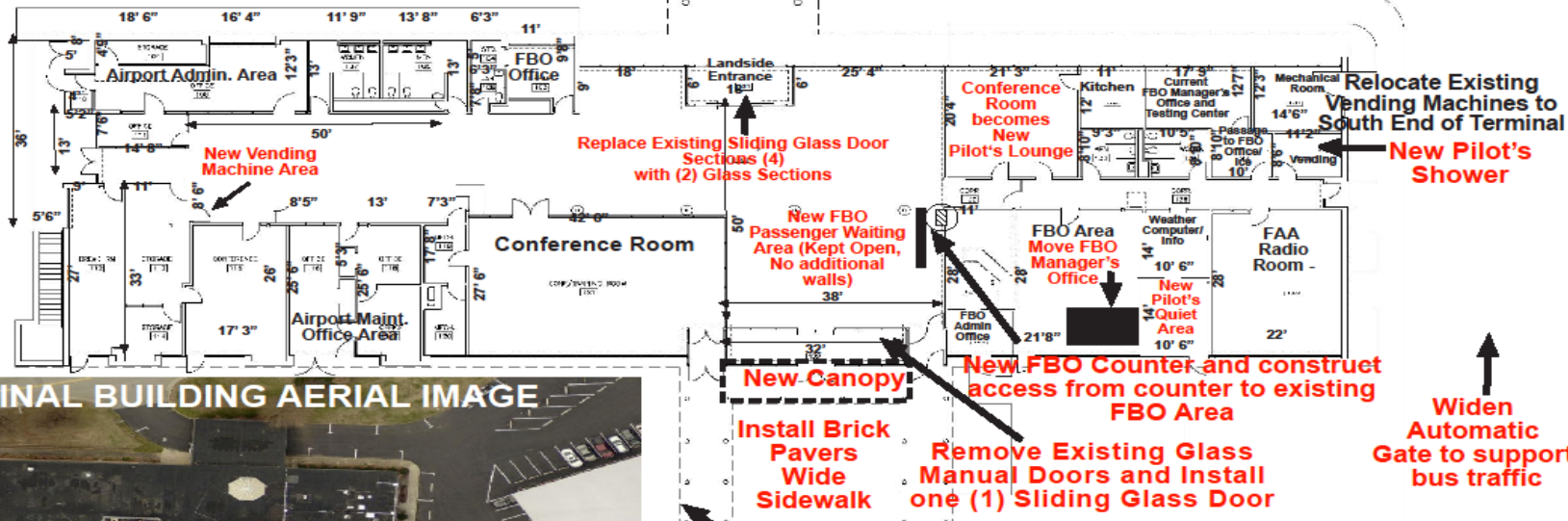

- New Ceiling Tile Grid and Light Fixtures Planned:**
- Existing FBO Area
 - Existing Conference Room/ New Pilot's Lounge
 - Existing Pilot's Lounge/New Quiet Area
 - Existing Vending Machine/ New Pilot's Shower
- New Furniture planned for New Passenger Waiting Area and New Pilot's Lounge**

AIRSIDE
Terminal Ramp

IMPROVE ACCESS FROM AIRSIDE TO TERMINAL



- Currently, all passengers and pilots enter the terminal from the ramp through the FBO door (blue awning). This door will be maintained for FBO employees.
- Customers will primarily use sliding glass door to enter terminal. **Existing canopy to be removed.**
- All concrete will be removed under the existing canopy and **brick pavers** will be installed in that area to **highlight new entrance** to terminal building. Signage to be installed to clarify new entrance.

COMPLETE INTERIOR MODIFICATIONS TO SUPPORT PASSENGER TRAFFIC FLOW TO LANDSIDE

CONSTRUCT DOOR TO EXISTING FBO AREA



REMOVE DOOR



INSTALL COUNTERTOP



REPLACE WITH SLIDING GLASS DOORS



REPLACE AND **RELOCATE FURNITURE AWAY** FROM SLIDING GLASS DOOR AREA



SIGNATURE FBO COUNTER AREA



**EXISTING CONFERENCE ROOM
BECOMES NEW PILOT'S LOUNGE**

**REPLACE CEILING TILES, VERTICAL BLINDS
AND LIGHT FIXTURES**

**ACCESS
TO EXISTING
KITCHEN**



**EXISTING KITCHEN LOCATED
ADJACENT TO CONFERENCE ROOM**

**REMOVE CONFERENCE
ROOM TABLE AND CHAIRS
AND **REPLACE** WITH
RECLINERS**

**EXISTING PILOT'S LOUNGE
BECOMES QUIET AREA
FOR PILOTS**

**RELOCATE
COMPUTER AND
WEATHER KIOSK TO
NEW PILOT'S
LOUNGE**

**NEW CEILING TILE GRID,
LIGHTS, BLACKOUT
SHADES**

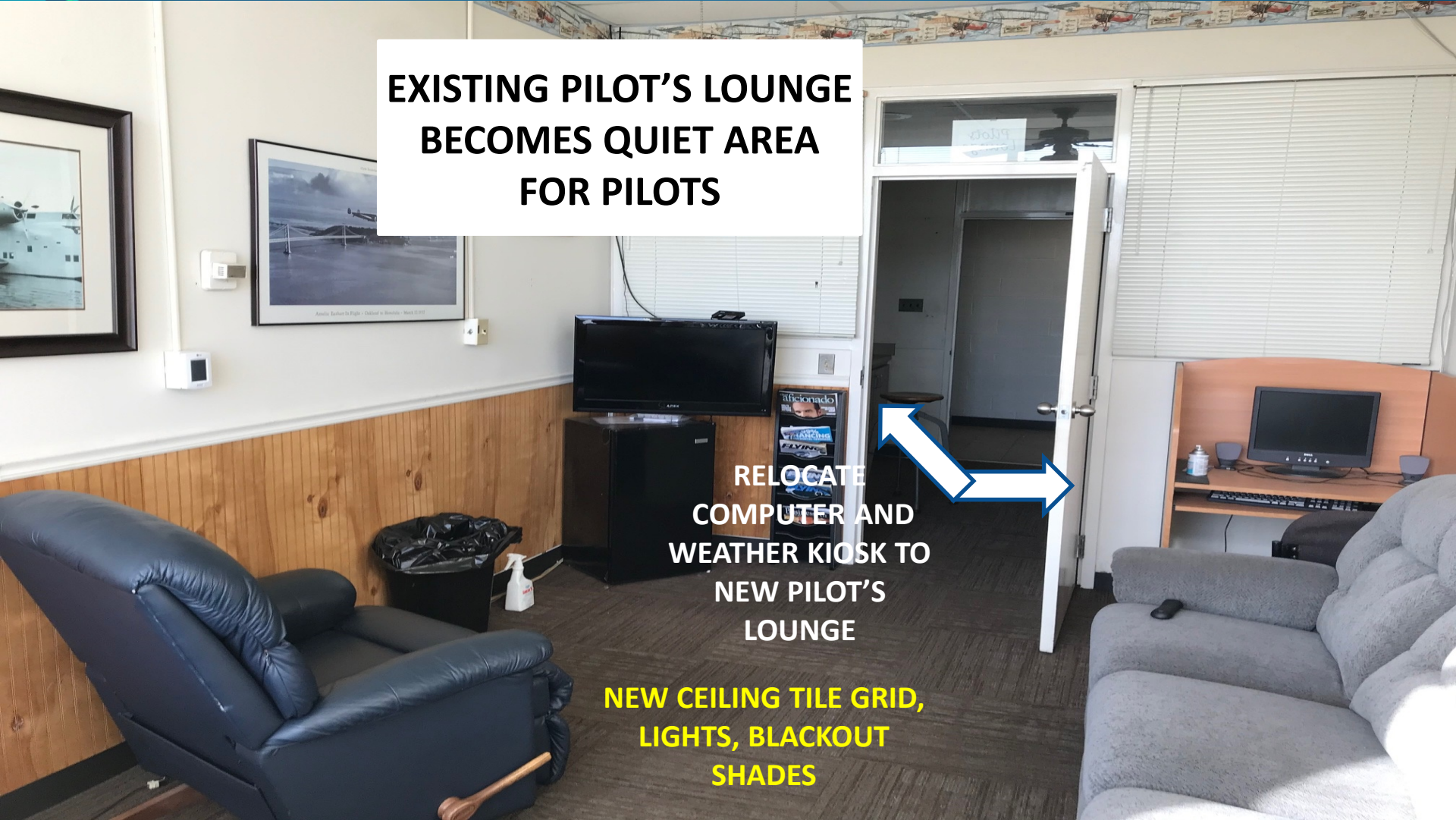

**CONVERT EXISTING VENDING MACHINE
AREA FOR USE AS A PILOT SHOWER**



**PILOT SHOWER
Raleigh Durham Airport FBO**



**VENDING
MACHINE
AREA**

**RELOCATE VENDING MACHINES TO SOUTH SIDE
OF TERMINAL BUILDING, RENOVATE
BATHROOMS AND REMOVE WALLPAPER AND
PAINT WALLS**

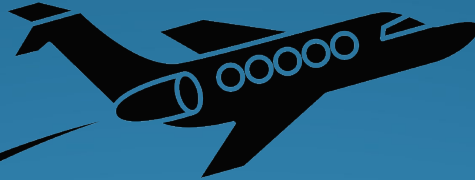

DANVILLE

REGIONAL AIRPORT

www.danvilleregionalairport.com

434-799-5110



VABA Update & Civil Air Patrol

Bud Oakey, VABA

Col. Elizabeth Sydow, CAP

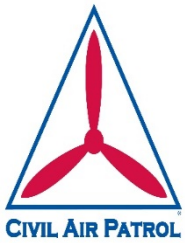

Virginia Wing Civil Air Patrol



CITIZENS SERVING COMMUNITIES

WWW.GOCIVILAIRPATROL.COM

WWW.VAWG.CAP.GOV

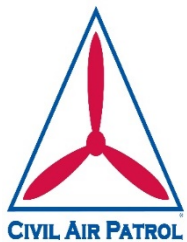

Civil Air Patrol / USAF Aux History



Formed December 1, 1941

- Congressionally chartered, nonprofit corporation
- United States Air Force Auxiliary, Civil Air Patrol

Today - Citizens Serving Communities

- Over 55,000 volunteer Airmen
- Aerospace Education
 - Leading K-12 youth and STEM organization
- Cadet Program
 - Over 21,800 cadets
- Emergency Services
 - Search and Rescue/Disaster Relief
 - 82 saved lives so far in FY 2021



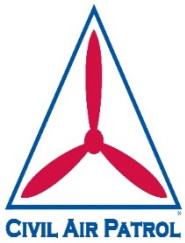

Virginia Wing

Members	1,780
Senior Members	935
Cadets	845
Powered Aircraft	12
Glider	1
Vehicles	31

Mission Bases	Group
Chesterfield	4
Culpeper	3
Winchester	3
Danville	1
Langley (pending)	2

Function	#
Mission Pilots	41
VFR Pilots	71
Ground Team Ldrs	50
Ground Team Mbrs	167
Comm Operators	158

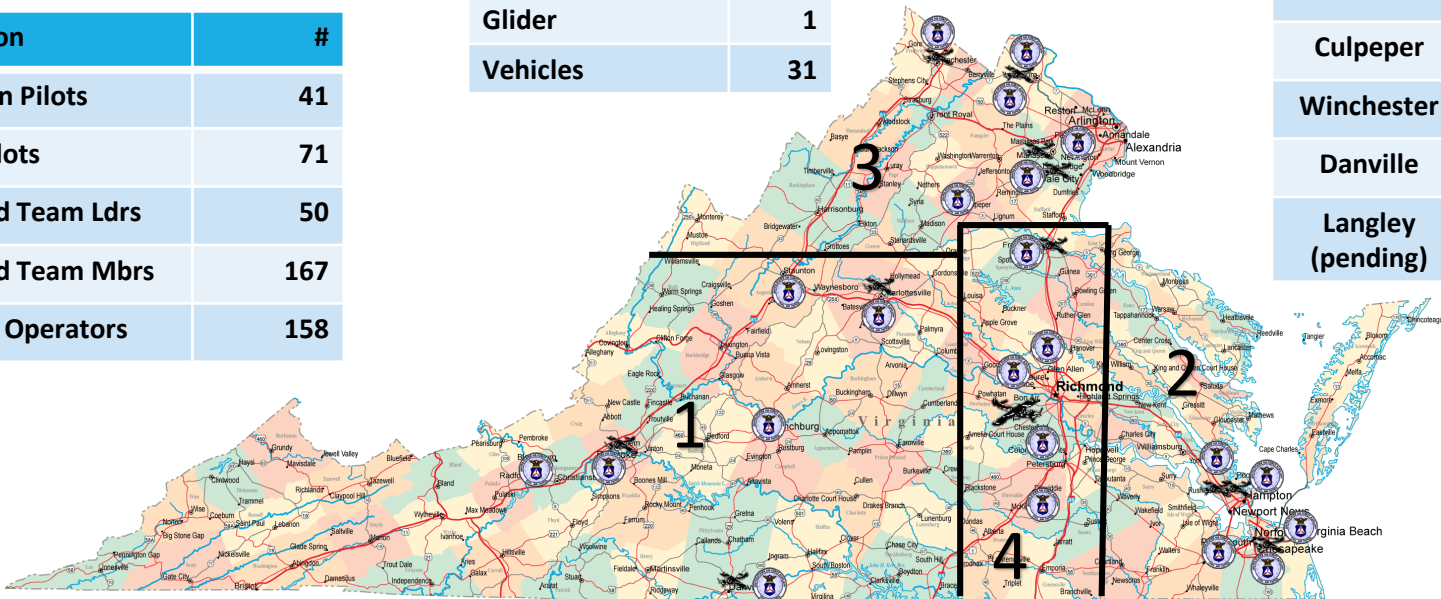

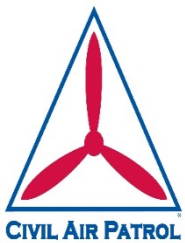

Aerospace/STEM Education



Aerospace Education Member (AEM)

- AEM available to K-12 & youth program educators
- Over 40 products available to STEM Teachers
- 20 FREE STEM kits: select one-at-a-time to use, evaluate, keep!
- Can earn Aerospace Education Excellence (AEX) Award
- Aligned w/ National Academic Standards, Pre K-12
- Teacher Orientation (TOP) Flight in a CAP airplane

Aerospace Connections in Education (ACE)

- Aerospace theme to promote academics (STEM-centric)
- Standards-based curriculum guide
- 21 lessons per grade level
- Grade-level class set of educational manipulatives



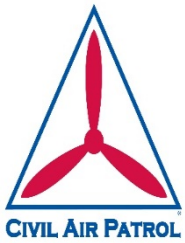

Virginia Wing AE/STEM Education



2020

- Worked with 3 new school districts for AEM membership
 - First-in-country COVID adaptation for STEM kit
- Limited TOP Flights (COVID-19)
- Increasing outreach to Home School
- Cyberpatriot and StellarXplorers

2021 (so far)

- Old Donation School Aviation Art project
- High Altitude Balloon Challenge (9 Virginia-based units)
- Region AE Brewer Lifetime Achievement Award
- Cubes in Space (6 of 80 experiments)
- Integrating AEM at Franklin Military Academy
- Restarting CAP TOP Flights for Teachers

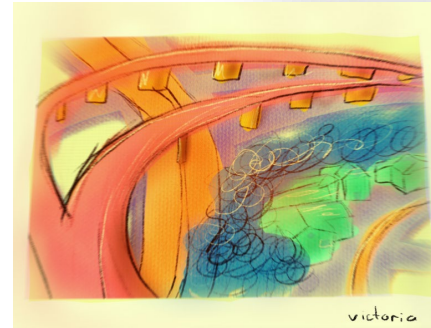

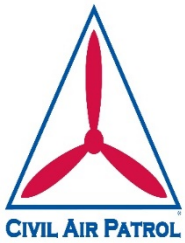

Cadet Programs



Citizen Program for Youth (Age 12-20)

- Develop leadership skills while exploring aviation and STEM careers
- Orientation Flights - eligible for 5 free powered flights and 5 free glider flights
 - 602 flights in Virginia since 1 Oct 2020 (498 powered, 104 glider)
 - Top glider program in CAP in 2021 (number of sorties)
- Scholarship Opportunities: Academic and Flight
- Flight Training
 - 17 Virginia cadets so far in 2021 (scholarships and self-funded)
 - National funding for proficiency once earn PPL



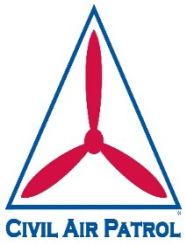

Emergency Services/Operations



- CAP's area of responsibility is border-to-border and coast-to-coast within the CONUS, plus Alaska, Hawaii, Puerto Rico, and the U.S. Virgin Islands
- CAP flies about 100,000 hours annually
 - 70% Mission Support
 - 30% Training
 - additional capacity is available to support customer needs
- Developing sUAS capability for ES missions



Gippsland GA-8 (16/1)



Cessna 182 (308/8)



Cessna 172 (187/3)

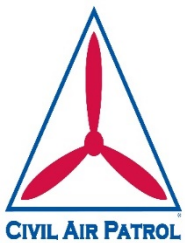

Virginia Emergency Services



Inland Search and Rescue, Disaster Relief, and State-Wide Communications

- **COVID-19 Support Missions**
 - Test kit transportation, Food distribution, Vaccine site support
- **Hurricane Isaias (USCG, USACOE, NWS, VDEM)**
 - Pre- and post-storm surveillance of coastline and channels into Norfolk Harbor
 - Aerial Photography of tornado sites and flew the VDEM Region Coordinator
 - “Fastest VDEM has ever been able to declare a disaster area”
- **Aerial Photography/Route Survey Disaster Assessment of Interstates & Virginia State Highways**



Fertile Keynote Air Defense Exercises

AFROTC & AFJROTC Orientation Flights

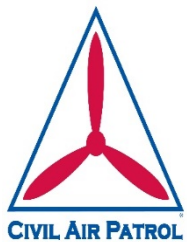

Communications

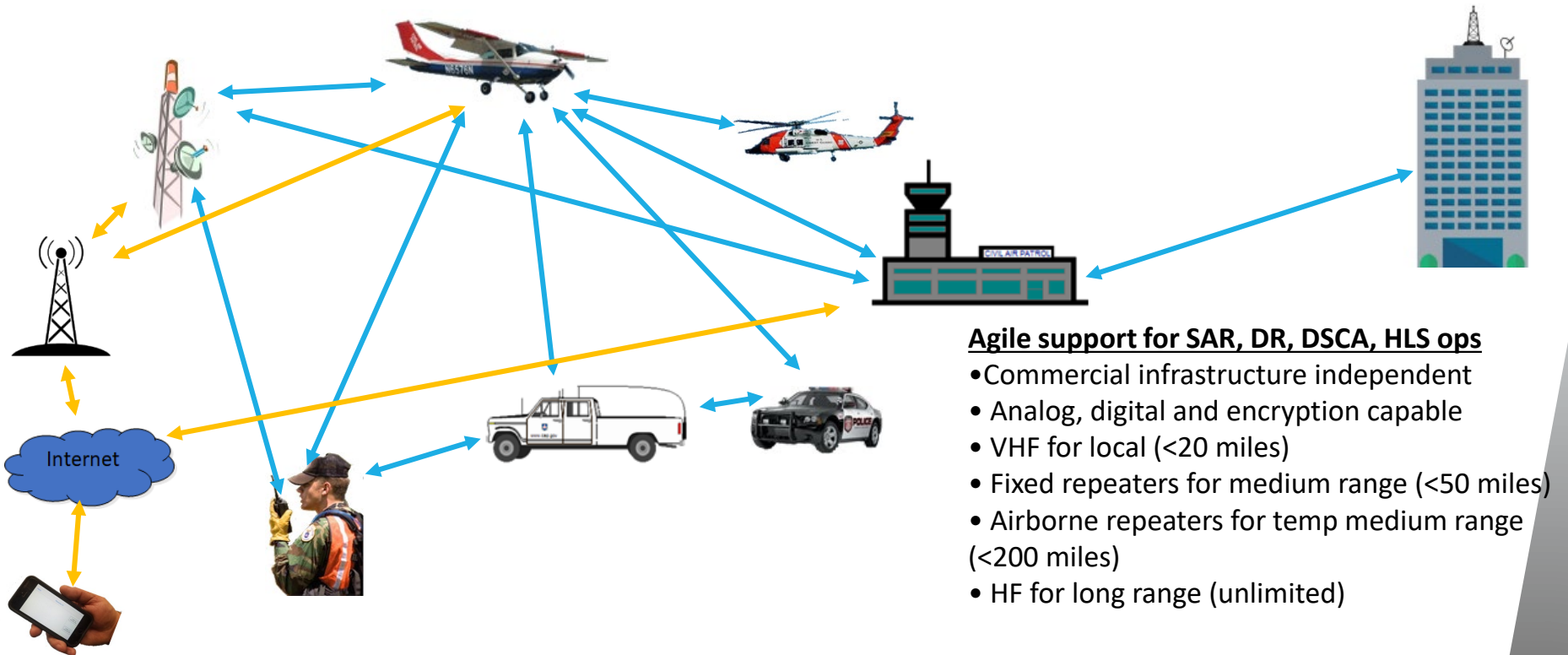

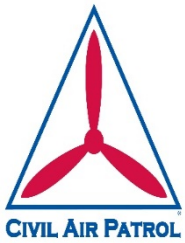

Virginia Wing Communications



VIRGINIA REPEATER SYSTEM Voice Repeater Site Listing by Name and Designator

Select Repeater by site "name".
Repeaters outside of Virginia can be selected by
R** for Analog or R**P for Digital Mode



MOUNT WEATHER - R14
MT WX P-R14P

VIEWTREE - R59
VIEW P - R59P

SKYLINE - R16
SKY P - R16P



Repeater
Network

HF-Network

VHF-FM
Network

Mobile
Radios

Airborne
Repeaters

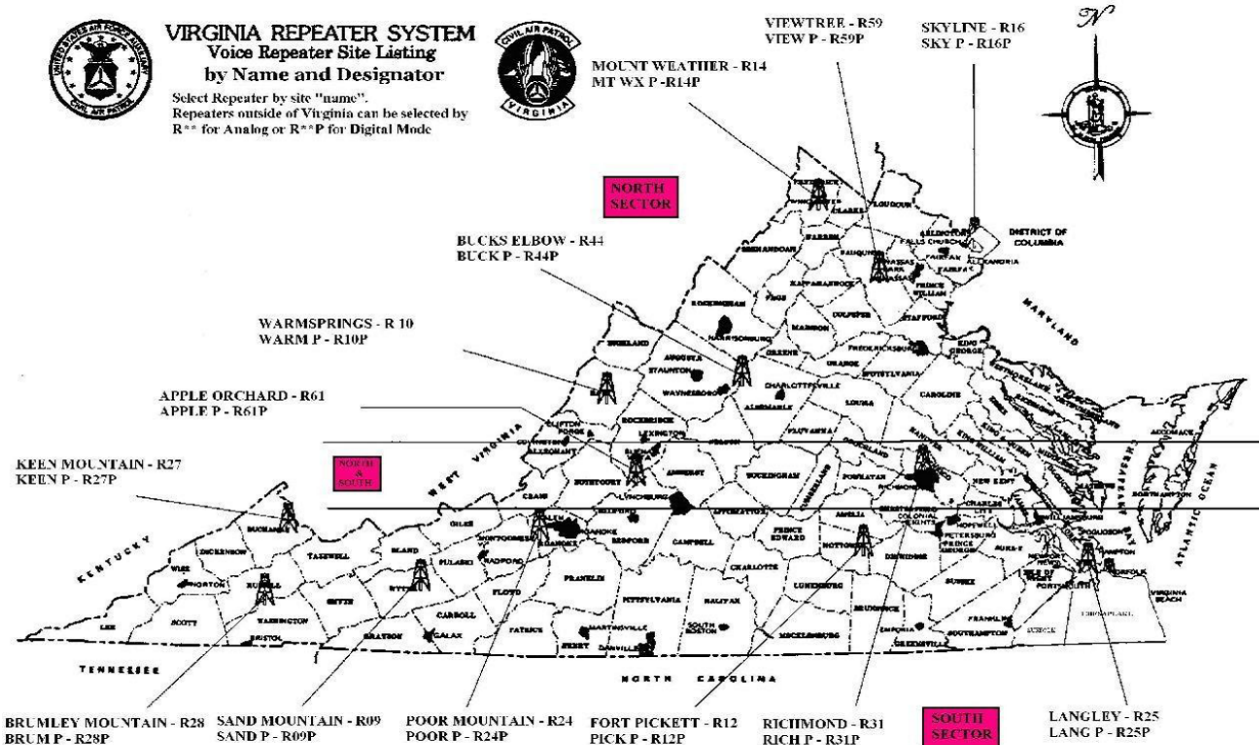

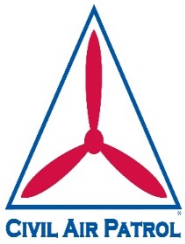

Contact	Email
Col Liz Sydow, CC, Virginia Wing	elizabeth.sydow@vawg.cap.gov
Lt Col Tim Day, CV, Virginia Wing	timothy.day@vawg.cap.gov
Lt Col Daniel "Bud" Oakey, CC, VA999	daniel.oakey@vawg.cap.gov
Lt Col Daniel Ciesla, VA999	daniel.ciesla@vawg.cap.gov
Maj Bob Thomas, CD, VA999	robert.thomas@vawg.cap.gov



Department Update

Mark Flynn

Director



Communications and Education Update

John Campbell, Director

Communications and Education



FAA-FSDO Update

Maury Dacey

VAOC Update

June 17, 2021 Virginia Aviation Board Meeting

Keith Holt, President, VAOC



VAOC ACTIVITIES

- We are formulating our Legislative Priorities for the upcoming session.
 - There has been discussion about VAOC looking to raise awareness and advocate for additional aviation funding.
 - Continued emphasis on airport's role in economic development
 - Post-pandemic recovery for airports and infrastructure



COVID-19 Impacts at Airports

- Some more recent positive numbers for passenger traffic
- We have achieved a better availability of access for vaccines for airport workers who want one
- Still working with federal mask mandates (Executive Order 13998) and educating the public on the mask requirements on airplanes and inside airports



Upcoming Programs

- Spring Workshop – Delayed (looking at November 2021)
- Virginia Aviation Conference – Norfolk, VA – August 17-19

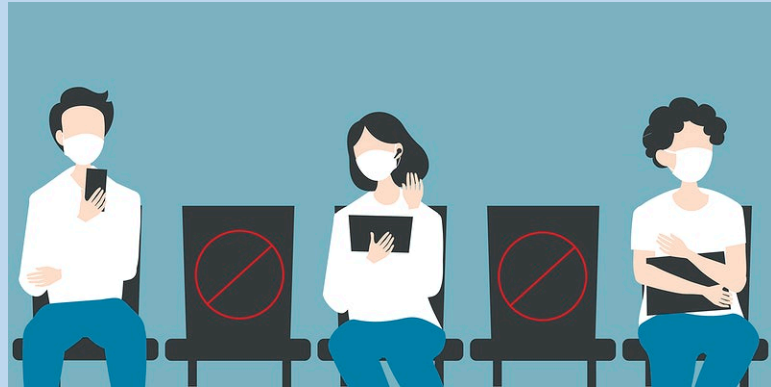



Keith Holt, C.M.
Airport Director
Virginia Tech/Montgomery Executive Airport
1601 Research Center Drive
Blacksburg, VA 24060
Phone: (540) 231-4444
Fax: (540) 231-7805
mgr@vtbcb.com





Review and Consideration of Proposed Changes to the *Airport Program Manual*

Cliff Burnette & Susan Simmers

Airport Services Division

June 17, 2021



Falwell Airport

Airport License
Renewal



Falwell Airport





Falwell Airport





INSTALLED WARNING SIGN



PROPOSED TWY CLOSURE MARKING



INSTALLED WARNING SIGN

PROPOSED TWY "HOLD POSITION MARKING"

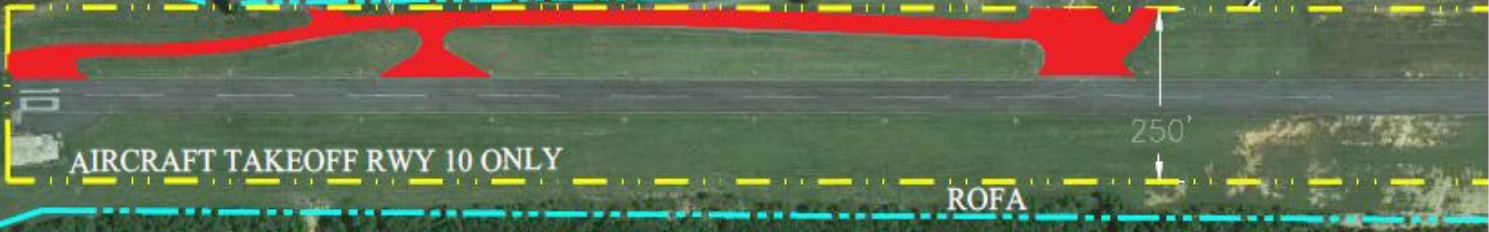

500 ft

Falwell Airport



W24 Airport Licensing Recommendation

- Extension of their Standard with waiver license till Sept. 1, 2021, (current license expires on 8/18/21).





Questions / Comments



Status of FY 2021 Commonwealth Aviation Fund

**Presented to:
Virginia Aviation Board**

**By;
Cliff Burnette
Director
Airport Services Division**

VDOT CAF Revenue Estimate Compared to CAF Revenues Received

Month	FY2021 VDOT-CAF Estimate	FY2021 VDOT-CAF Running Total	FY2021 CAF Revenue Received	FY2021 CAF Revenue Running Total	Running Difference VDOT-CAF Estimate & CAF Revenue Received
July	\$2,048,989	\$2,048,989	\$1,750,685	\$1,750,685	-14.6%
August	\$2,048,989	\$4,097,978	\$2,029,742	\$3,780,427	-7.7%
September	\$2,048,989	\$6,146,967	\$2,860,302	\$6,640,729	8.0%
Qtr. Interest	\$31,251	\$6,178,218	\$46,699	\$6,687,428	8.2%
1st. Qtr. Total	\$6,178,218		\$6,687,428		8.2%
October	\$2,048,989	\$8,227,207	\$1,749,068	\$8,436,496	2.5%
November	\$2,048,989	\$10,276,196	\$1,995,701	\$10,432,197	1.5%
December	\$2,048,989	\$12,325,185	\$2,435,076	\$12,867,273	4.4%
Qtr. Interest	\$31,251	\$12,356,436	\$31,190	\$12,898,462	4.4%
2nd Qtr. Total	\$6,178,218		\$6,211,035		0.5%
January	\$2,048,989	\$14,374,174	\$2,080,763	\$14,979,226	4.2%
February	\$2,048,989	\$16,423,163	\$2,327,690	\$17,306,916	5.4%
March	\$2,048,989	\$18,472,152	\$2,265,802	\$19,572,718	6.0%
Qtr. Interest	\$31,251	\$18,503,403	\$28,078	\$19,600,795	5.9%
3rd Qtr. Total	\$6,178,218		\$6,702,332		8.5%
April	\$2,048,989	\$20,521,141	\$2,335,098	\$21,935,893	6.9%
May	\$2,048,989	\$22,570,130	\$2,340,358	\$24,276,251	7.6%
June	\$2,048,989	\$24,619,119			
Qtr. Interest	\$31,251	\$26,668,108			
4th. Qtr. Total	\$6,178,218		\$4,675,456		
FY2021 Total	\$24,712,872		\$24,276,251		

Source:
my.cardinal.
Virginia.gov

4th Qtr.
revenue
trending
above
forecast

Total
revenue
collected
to date



Questions / Discussion

For Additional Information Contact:

Cliff Burnette

Director,

Airport Services Division

Office: 804/236-3646

Email: cliff.burnette@doav.virginia.gov



Aviation Special Fund Status

**Mark Flynn, Director
DOAV
June 17, 2021**



VRA – Airports Bond Defeasance

**Mike Swain
DOAV
June 17, 2021**





presentation to the
Virginia Aviation Board

June 17, 2021

What is a statewide aviation system plan?

- Roadmap for airport development across the system
- Evaluate airport system performance
- Evaluate state agency performance
- Other purposes, based on state resources, responsibilities, and authority, to address funding, programming, etc.

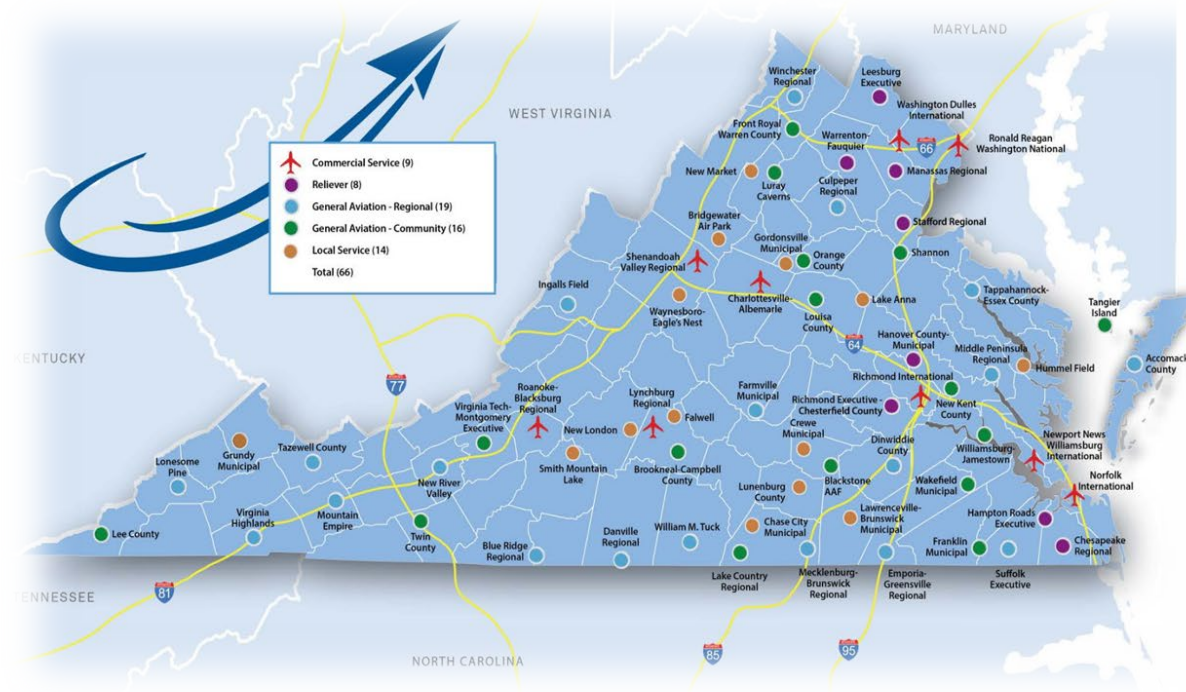

Virginia has conducted system planning for 72 years

- Original plan “*Aviation in Virginia*” was published in November 1949.
- The original *Virginia Air Transportation System Plan* (VATSP) was published in 1975.
- Updates to the VATSP were published in:
 - 1981
 - 1990
 - 1996
 - 2003
 - 2016
- The VATSP is updated every 5-10 years. Examples that cause an update include: trends in statewide economic and aviation growth, new facility and technology requirements, and availability of state and federal funding.

FAA supports system planning and provides guidance

- **Guided by FAA's AC 150/5070-7, Chg. 1**

The Airport System Planning Process

"...determine the type, extent, location, timing, and cost of the airport development needed in a state or metropolitan area to establish a viable system of airports."

- **Necessary to maintain federal funds**

Figure 1: Integrated Airport System Planning

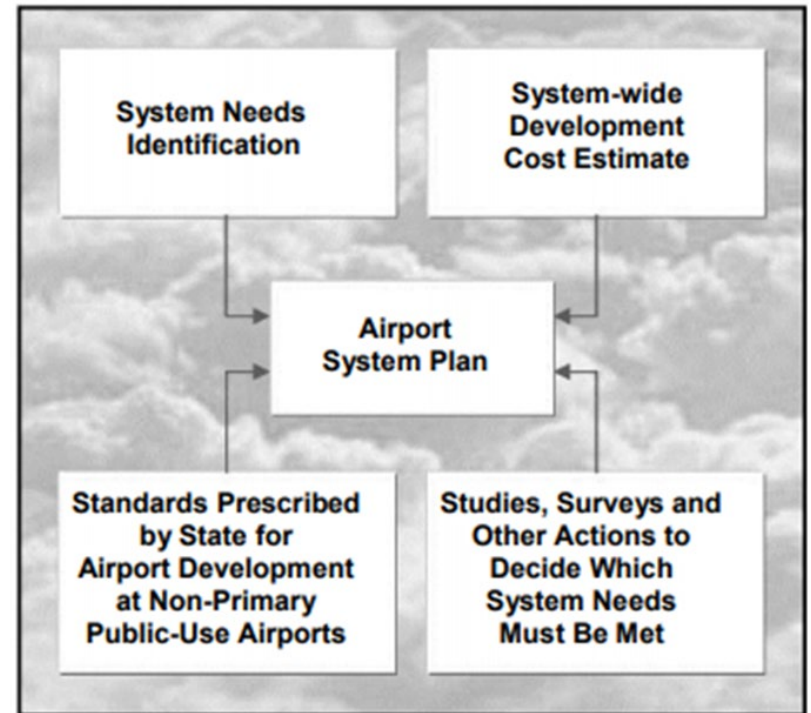

What will the VATSP update study provide Virginia?

- **Project Management and Goals/Objectives Analysis**
- **Task 1 – Inventory/Peer Review**
- **Task 2 – Forecasts of Activity**
- Task 3 – Facility Requirements
- Task 4 – Cost Evaluation
- Task 5 – Alternatives
- Task 6 – Funding Analysis
- Task 7 – Recommendations
- Task 8 – Implementation Plan
- Task 9 – Final Deliverables (Technical Report and Executive Summary)
- **Task 10 – Public Involvement**

VATSP update study will be completed in 12-15 months

VAB will receive updates at board meetings

Role of the Study Advisory Group (SAG)

- **Be ambassadors of the VATSP**
- Provide input into the study
- Bring perspectives from airport/industry
- Provide a conduit for communication
- Engage in the process
- 8 meetings, at key milestones during the study period



SAG membership is well represented by Virginia airport professionals

- **Virginia Department of Aviation**
 - Mark Flynn
 - Cliff Burnette
 - Rusty Harrington
- **VAB Members**
 - Dak Hardwick
 - Vicki Cox
- **Air Carrier Airports**
 - Charles Braden (ORF)
 - Greg Campbell (SHD)
 - Perry Miller (RIC)
 - Andrew Ndolo (MWAA)
- **GA Airports**
 - Jason Davis (MTV)
 - Scott Coffman (JYO)
 - Keith Holt (BCB)
 - Debbie Kendall (GVE)
 - Chris Schrantz (CPK)
 - Donnie Rose (LNP)

Highly qualified and experienced study team



Prime Consultant

Mead&Hunt

Sub-Consultant



Questions – Comments welcomed



- Department of Aviation
 - Rusty Harrington
Project Manager
 - Rusty.Harrington@doav.virginia.gov
 - 804-236-3522
- Mead & Hunt
 - Stephanie Ward
Project Manager
 - Stephanie.ward@meadhunt.com
 - 517-908-3121

Project Prioritization Process – *Airport Program Manual*

**Cliff Burnette
DOAV
June 17, 2021**



Project Priority System

presentation to the

Virginia Aviation Board

June 17, 2021



Discussion Topics

- ❖ Review of Project Approval Process
- ❖ History of the Project Priority System
- ❖ Purpose of the Project Priority System
- ❖ Operation of the Project Priority System
- ❖ Questions/Discussion



Project Approval Process

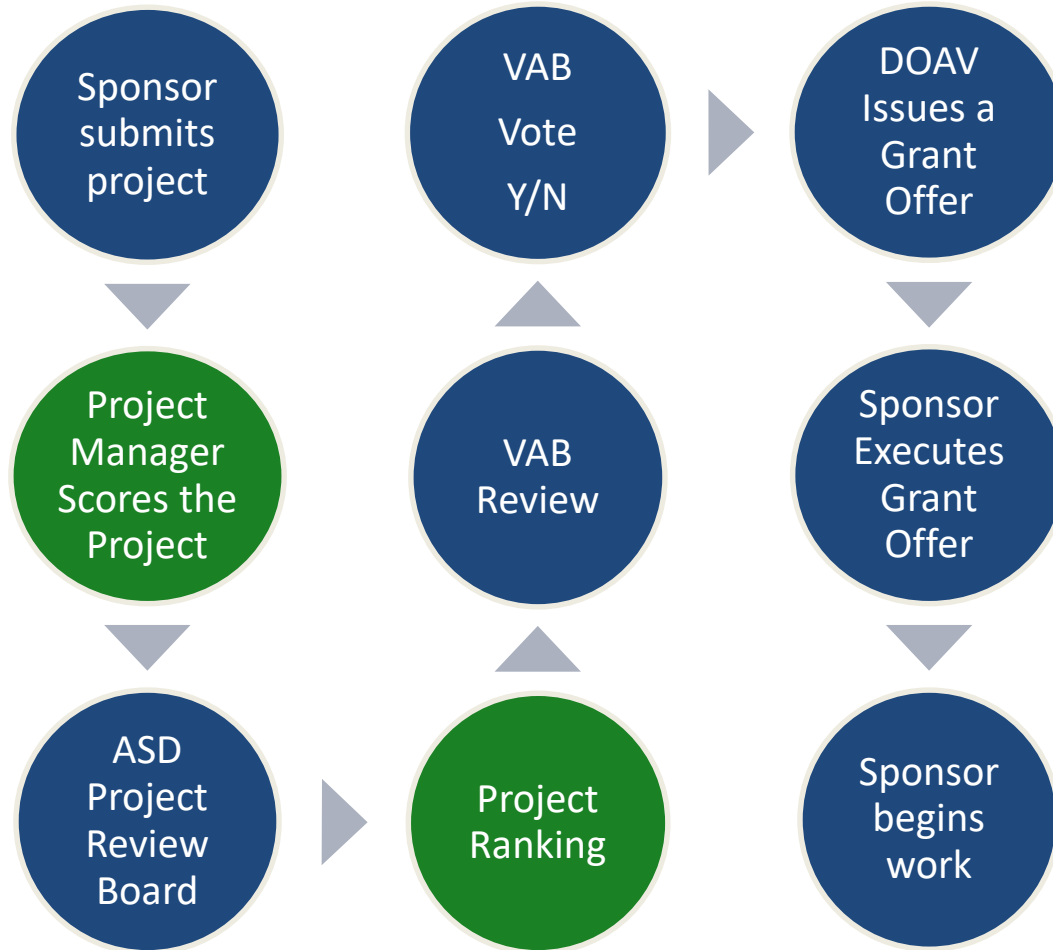

History of the Project Priority System

- ❖ The Project Priority Model was designed with the input of a working group represented by the VAB, VDOT, airport sponsors, and the Department.
- ❖ The Project Priority Model has been used by the VAB and the Department since 1987.
- ❖ While several new variables have been added, point values for the original variables have remained unchanged since the origination of the model.



Purpose of the Project Priority System

- ❖ The Project Priority System is a resource allocation model that uses objective criteria to rank projects.
- ❖ The project ranking is used by the VAB to consider the allocation of constrained discretionary Commonwealth Aviation Funds (CAF).
- ❖ The intent of the Project Priority Model is to assure that projects that will have the greatest impact will be funded.



Sources of Commonwealth Aviation Fund Discretionary Funds

Commonwealth Aviation Fund (CAF) Discretionary Projects are funded from three different funding sources:

- ❖ Air Carrier and Reliever Airport Discretionary Fund.
- ❖ General Aviation Airport Discretionary Fund.
- ❖ Combined Discretionary Fund (second half of fiscal year)



Projects are evaluated within the following four categories

- ❖ *Category 1* – Project Merit description (0-55)
- ❖ *Category 2* – Situational Considerations

Special Project Considerations

- Phased project (0 or 50)
- Mandated; Federal or State Law (0 or 25)
- VAB Policy (0 or 10)



❖ *Category 2* – Situational Considerations

Special Project Considerations (cont'd)

- Economic Development Potential (0 or 10)
- Discretionary Considerations
 - Local Funding Exceeding Minimum, 1 point for each percent exceeding
- FAA Funding Availability (0 or 20)
- Retains/Attracts Commercial Service (0 or 10)



- ❖ *Category 3 – Operational Considerations*
 - Minimum Safety Standards (0, 10, or 25)
 - Airport Safety Zoning (0 or 10)
 - Airport Maintenance (0 or -10)
 - Service Role; Reliever (0 or 10)
 - Secure Airport Certification (0 or 15)
 - IT Security Training Certification (0 or 15)



- ❖ *Category 4 – Airport Activity Category*
 - Based Aircraft (5, 10, 15, 20, or 25)
 - Aircraft Operations (10, 15, 20, or 25)
 - Enplanements (air carrier airports) (0, 10, 15, 20, or 25)
 - Reliever Airport (0 or 10)



Range of Points

<u>Airport</u>	<u>Min.</u>	<u>Max.</u>
G.A.	11	250
Reliever	21	260
Air Carrier	11	270



Operation of the Project Priority System

Example 1 – Apron Expansion (Design)

	<u>EMV</u>	<u>OKV</u>
Project	17	17
Based aircraft	10	25
Aircraft operations	10	25
Height restrictive zoning	10	10
Minimum safety standards	25	25
Secure airport certification	15	15
IT security training certification	15	15
Total	102	132



Operation of the Project Priority System

Example 2 -

EMV – Obstruction Removal (Part 77) (Design) vs.

OKV – Terminal Building Expansion (Design)

	<u>EMV</u>	<u>OKV</u>
Project	52	12
Based aircraft	10	25
Aircraft operations	10	25
Height restrictive zoning	10	10
Minimum safety standards	25	25
Secure airport certification	15	15
<u>IT security training certification</u>	<u>15</u>	<u>15</u>
Total	137	127



Questions/Discussion



Consideration of Amended FY21 Entitlement Utilization Plans

**Mike Swain
DOAV
June 17, 2021**



Virginia Aviation Board Review Tentative Allocations from the Commonwealth Aviation Fund

**Mike Swain
DOAV
June 17, 2021**



Public Comment Period



Board Member Comments and Reports





Virginia Aviation Board

June 2021

Board Package

Virginia Aviation Board Meeting Agenda Thursday, June 17, 2021

The Virginia Aviation Board will hold a meeting at 10:00 a.m., Thursday, June 17, 2021 at the Virginia Department of Aviation, Passenger Terminal Hangar, 5702 Gulfstream Road, Richmond, VA 23250. The meeting is available through webex: <https://covaconf.webex.com/covaconf/onstage/g.php?MTID=e9e94cc0479c40fb9099ec5dc6a90c1d4> or by calling 1-517-466-2023 with access code: 161 060 5356

Following CDC guidelines and the Governor's guidance, individuals considered fully vaccinated are not required to wear face coverings. Face coverings are required for those not considered fully vaccinated.

- | | | |
|--|---|--------------|
| 1. Call to Order | Rod Hall, Chairman | (5 minutes) |
| 2. Review and approve March 18, 2021 minutes | Rod Hall, Chairman | (5 minutes) |
| 3. Recognition of Outgoing Board Member-Jack Kennedy | Rod Hall, Chairman | (5 minutes) |
| 4. Updates and Announcements: | | |
| A. Danville Airport Presentation | Marc Adelman,
Transportation
Services Director,
Danville | (15 minutes) |
| B. DOAV Update | Mark Flynn
DOAV | (15 minutes) |
| 1. Advanced Air Mobility | | |
| 2. Sustainable Aviation Fuel | | (5 minutes) |
| Communications & Education Update | John Campbell
DOAV | |
| C. FAA-FSDO Update | Maury Dacey
FAA | (10 minutes) |
| D. VAOC Update | Keith Holt
VAOC | (10 minutes) |
| E. Civil Air Patrol & VABA Update | Bud Oakey
VABA | (10 minutes) |
| 5. Old Business | | |
| A. <i>Airport Program Manual</i> | Cliff Burnette/
Susan Simmers
DOAV | (30 minutes) |
| B. Airport Licensing Issues – Falwell Airport | Vernon Carter
DOAV | (5 minutes) |
| C. Commonwealth Aviation Fund Status | Cliff Burnette
DOAV | (5 minutes) |
| D. Aviation Special Fund Status | Mark Flynn
DOAV | (5 minutes) |

- | | | |
|---|------------------------|--------------|
| 6. New Business | | |
| A. Virginia Air Transportation System Plan (VATSP) Update | Cliff Burnette
DOAV | (10 minutes) |
| B. Project Prioritization Process – <i>Airport Program Manual</i> | Cliff Burnette
DOAV | (15 minutes) |
| C. VRA - Airports Bond Defeasance | Mike Swain
DOAV | (5 minutes) |
| D. Consideration of Amended FY21 Entitlement Utilization Plans | Mike Swain
DOAV | (10 minutes) |
| 1. Charlottesville-Albemarle Airport | | |
| 2. Lynchburg Regional Airport | | |
| 3. Newport News/Williamsburg International Airport | | |
| 4. Shenandoah Valley Regional Airport | | |
| E. Virginia Aviation Board Review
Tentative Allocations from the Commonwealth Aviation
Fund | Mike Swain
DOAV | (15 minutes) |
| | Rod Hall, Chairman | |
| 7. Public Comment Period
(3 minutes per person to address the board) | Rod Hall, Chairman | (5 minutes) |
| 8. Board Member Comments and Reports | Rod Hall, Chairman | |
| 9. Adjournment | | |



Virginia Aviation Board
Meeting Minutes

A meeting of the Virginia Aviation Board was held on Thursday, March 18, 2021, at the Virginia Department of Aviation, Passenger Terminal Hangar, 5702 Gulfstream Road, Richmond, VA 23250. The meeting was also available by electronic media and was audio recorded. The audio recording, meeting documents, and presentation materials are available on the Virginia Department of Aviation's website, www.doav.virginia.gov.

MEMBERS

Roderick D. Hall, Chairman	Present
J. Jack Kennedy, Jr., Region 1	Present
Victoria Cox, Region 2	Present
Derek M. Hardwick, Region 3	Present
Alan C. Abbott, Region 4	Present
Maggie Ragon, Region 5	Present
TBD, Region 6	N/A
Vanessa Christie, Region 7	Present

OTHER ATTENDEES

	Office of the Attorney General
Mark K. Flynn, Director	Virginia Department of Aviation

DOAV staff, state government representatives, federal government representatives, airport sponsors and managers, consultants, engineers, business owners, and city and county representatives were also present.

1. Call to Order Dak Hardwick,
Vice-Chairman

The chairman called the meeting to order at 10:12 a.m.

2. Review and approve January 14, 2021 minutes Dak Hardwick,
Vice-Chairman

Motion to approve: Kennedy

Second: Abbott

Vote: Aye: Kennedy, Cox, Abbott, Ragon, Christie; Nay: none

3. Update and Announcements:

A. DOAV Update	Mark Flynn, DOAV
----------------	------------------

Director Flynn provided an update on DOAV activities and the Advanced Air Mobility (AAM) program. Mr. Kennedy commented on Florida's efforts to attract and develop AAM activity. Board members expressed great interest in pursuing the tools and policies to incorporate AAM into Virginia's aviation system. Mr. Hardwick requested AAM updates be added as a stated agenda item for future meetings.

Communications & Education Update

John Campbell, DOAV

Mr. Campbell provided an update on the department's communications and education activities.

B. FAA-FSDO Report

Maury Dacey, FAA

Mr. Dacey provided an updated on FAA-FSDO activities.

C. VAOC Report

Keith Holt, VAOC

Mr. Holt provided an updated on VAOC activities.

D. VABA Report

Bud Oakey, VABA

Mr. Oakey provided an update on VABA activities.

4. Old Business

A. Airport Program Manual

Mark Flynn, DOAV

Director Flynn provided noted that as a result of committee recommendations, revised language was being presented to the board for their review and consideration for approval. After a great deal of discussion between board members, airport representatives and DOAV staff, Mr. Hardwick made a motion to approve the *Airport Program Manual* revisions, with the exception of Section 2.4.10. He recommended Section 2.4.10 be discussed, revised, and submitted for board consideration at the next meeting. Mr. Flynn stated DOAV will work with VAOC on the outstanding issue.

Motion to approve: Hardwick

Second: Kennedy

Vote: Aye: Kennedy, Cox, Hardwick, Abbott, Ragon, Christie; Nay: none

B. Airport Licensing Issues

Vernon Carter
DOAV

1. Falwell Airport

Mr. Carter provided additional information regarding sponsor proposed safety recommendations. While the license was extended for up to six months, the department will work with the sponsor to implement the proposed safety recommendations and present an update to the board once completed.

2. William M. Tuck Airport

Mr. Carter provided obstruction information regarding the turf runway and the timeline of events and communications. Staff recommended that the public-use license for the turf runway be revoked.

Motion to approve: Ragon

Second: Christie

Vote: Aye: Kennedy, Cox, Hardwick, Abbott, Ragon, Christie; Nay: none

- C. Commonwealth Aviation Fund Status Cliff Burnette
DOAV

Mr. Burnette provided an updated on the status of the Commonwealth Aviation Fund.

- D. Aviation Special Fund Status Mark Flynn
DOAV

Mr. Flynn provided an updated on the status of the Aviation Special Fund.

5. New Business

- A. VRA Loan Applications Mike Swain, DOAV

Mr. Swain presented the following Virginia Resources Authority (VRA) loan requests. Staff recommended endorsement of the requests for the Charlottesville-Albemarle Airport and Louisa County Airport. Staff recommended the conditional endorsement of the request for the Roanoke-Blacksburg Regional Airport awaiting the receipt of the environmental determination from FAA.

Airport	Project	Amount
Charlottesville-Albemarle Airport	Economy Parking Lot Expansion-Refinancing	\$1,949,031.00
Louisa County Airport	Box Hangar Construction	\$400,000.00
Roanoke-Blacksburg Regional Airport	Land Acquisition - Future Development	\$3,200,000.00

Motion to approve: Cox

Second: Ragon

Vote: Aye: Kennedy, Cox, Hardwick, Abbott, Ragon, Christie; Nay: none

- B. Consideration of Amended FY21 Entitlement Utilization Plans Mike Swain, DOAV

Mr. Swain presented revisions to FY21 Entitlement Utilization Plans for Norfolk International Airport and Shenandoah Valley Regional Airport. Staff recommended approval of the amended plans.

Motion to approve: Hardwick

Second: Christie

Vote: Aye: Kennedy, Cox, Hardwick, Abbott, Ragon, Christie; Nay: none

- C. Virginia Aviation Allocations Review Mike Swain, DOAV
Tentative Allocations from the Commonwealth Airport Fund

1. Impact of Federal Relief Funds

As federal legislation is moving forward with 100 percent funding for AIP projects, staff recommended

- If a sponsor receives a tentative allocation from the Virginia Aviation Board, and then receives an FAA AIP grant offer for 100% of the project costs, the tentative allocation shall be automatically revoked, and the Department is directed to withdraw the tentative allocation.
- If a sponsor executes a state grant offer, and then receives an FAA AIP grant offer for 100% of the project costs, the sponsor must repay the Department of Aviation for any reimbursements previously received, and the Department of Aviation will close the state grant.

Motion to approve: Kennedy

Second: Hardwick

Vote: Aye: Kennedy, Cox, Hardwick, Abbott, Ragon, Christie; Nay: none

2. Review of Tentative Allocations

Mr. Swain presented the project requests and staff recommendations. The board actions are summarized below. These results are available at www.doav.virginia.gov.

For Region 1, staff recommended the following:

Airport	Project Description	VAB Action	Amount
Blue Ridge Regional Airport	Land Acquisition Services Runway 13 RPZ/Part 77 - BRIDGE LOAN	Approve	\$33,947.00
Lonesome Pine Airport	Runway 6-24 Rehabilitation (Construction)	Approve	\$480,000.00
New River Valley Airport	Master Plan Update	Approve	\$40,000.00
	Parking Lot Rehabilitation (Design/Construction)	Approve	\$86,882.00
	Taxiway Crack Seal (Construction)	Approve	\$2,960.00
Tazewell County Airport	T-Hangar Site Preparation (Construction)	Approve	\$400,000.00
Twin County Airport	Box Hangar Site Preparation (Environmental Reimbursement & Design)	Approve	\$48,000.00
Virginia Highlands Airport	Runway 6-24 Extension - Phase 5 (Embankment Season 3) (Construction)	Approve	\$334,000.00
Virginia Tech - Montgomery Executive Airport	Additional Security Cameras	Approve	\$3,442.00
	Runway 12-30 Extension - Land Acquisition - Phase 3	Approve	\$57,777.00
	Runway 12-30 Extension - Phase 2 (Construction) - INCREASE	Approve	\$81,517.53

Motion to approve: Kennedy

Second: Hardwick

Vote: Aye: Kennedy, Cox, Hardwick, Abbott, Ragon, Christie; Nay: none

For Region 2, staff recommended the following:

Airport	Project Description	VAB Action	Amount
Bridgewater Air Park	Runway/Taxiways Crackseal, Sealcoat, and Re-Marking (Design)	Approve	\$16,800.00
Front Royal-Warren County Airport	Terminal Roof Replacement (Design)	Approve	\$3,198.00
Gordonsville Municipal Airport	Runway, Taxiway & Apron Rehabilitation (Construction)	Approve	\$1,056,101.00
Luray Caverns Airport	Terminal Building (Design)	Approve	\$144,000.00
	Terminal Site Preparation (Design)	Approve	\$60,000.00

Motion to approve: Cox

Second: Kennedy

Vote: Aye: Kennedy, Cox, Hardwick, Abbott, Ragon, Christie; Nay: none

For Region 3, staff recommended the following:

Airport	Project Description	VAB Action	Amount
---------	---------------------	------------	--------

Culpeper Regional Airport	Stormwater Pollution Prevention Plan & Spill Prevention Control & Countermeasures Plan Updates	Approve	\$15,936.38
Manassas Regional Airport	Access Roads/Parking Lot - Pavement Mill/Replace/Restripe	Approve	\$85,186.00
	Master Plan Update	Approve	\$48,000.00
Stafford Regional Airport	Runway Extension - Phase 2 (Construction)	Approve	\$464,000.00
Winchester Regional Airport	Terminal Area Site Preparation - Phase 2 (Design)	Approve	\$195,200.00
	Terminal Building (Design)	Approve	\$231,000.00

Motion to approve: Hardwick

Second: Ragon

Vote: Aye: Kennedy, Cox, Hardwick, Abbott, Ragon, Christie; Nay: none

For Region 4, staff recommended the following:

Airport	Project Description	VAB Action	Amount
Hanover County Municipal Airport	Runway 16 Remarking	Approve	\$8,400.00
	Runway 16/34 Rehabilitation (Design)	Approve	\$32,000.00
	Spill Prevention Control & Countermeasures Plan Update	Disapprove	N/A
Richmond Executive-Chesterfield County Airport	Airfield Drive Rehabilitation (Design)	Approve	\$80,800.00
	Fueling System (Demolition) and Fueling Truck Parking Area (Construction)	Approve	\$200,000.00
	Southeast Hangar Apron (Design)	Disapprove	N/A

Motion to approve: Abbott

Second: Christie

Vote: Aye: Kennedy, Cox, Hardwick, Abbott, Ragon, Christie; Nay: none

For Region 5, staff recommended the following:

Airport	Project Description	VAB Action	Amount
Crewe Municipal Airport	Terminal Building Roof Repairs	Approve	\$5,980.00
Danville Regional Airport	Taxiway 'H' Widening and Hangar Site Development (Construction)	Approve	\$1,122,101.00
	Terminal Building Renovation (Design)	Approve	\$55,922.00
Dinwiddie County Airport	Runway Crack Seal	Approve	\$18,644.00
Farmville Regional Airport	Maintenance Equipment Storage Building - Replacement (Construction)	Approve	\$88,476.00

Motion to approve: Ragon

Second: Abbott

Vote: Aye: Kennedy, Cox, Hardwick, Abbott, Ragon, Christie; Nay: none

For Region 6, staff recommended the following:

Airport	Project Description	VAB Action	Amount
---------	---------------------	------------	--------

Lake Country Regional Airport	Runway Rehabilitation & RSA Grading (Construction) - Phase 3	Approve	\$872,000.00
-------------------------------	--	---------	--------------

Motion to approve: Hardwick

Second: Ragon

Vote: Aye: Kennedy, Cox, Hardwick, Abbott, Ragon, Christie; Nay: none

For Region 7, staff recommended the following:

Airport	Project Description	VAB Action	Amount
Accomack County Airport	Fuel Truck Containment Area - Environmental Coordination (CatEx)	Approve	\$12,800.00
	Runway 21 Turnaround (Design)	Approve	\$6,000.00
	Wetland Credits Reallocation - Runway 21 Turnaround (Design)	Approve	N/A (scope change)
Hampton Roads Executive Airport	Taxiway Asphalt Repair (Patching, Milling, Crack Fill)	Approve	\$15,447.00
	West Apron Taxiways Rehabilitation (Construction)	Approve	\$40,000.00
Hummel Field	Airport Layout Plan Update	Approve	\$35,990.00
	Environmental Impact Review	Disapprove	N/A
Middle Peninsula Regional Airport	Access Road & Box Hangar Site Preparation (Environmental)	Disapprove	N/A
	Pavement Repair (Runway, Taxiway, Fuel Farm, Apron, Parking Lot, and Hangar)	Approve	\$24,035.00
	Transient Apron Security Lighting (Design)	Disapprove	N/A
Williamsburg-Jamestown Airport	T-Hangar #2 Site Preparation (Design)	Approve	\$36,800.00

Motion to approve: Christie

Second: Ragon

Vote: Aye: Kennedy, Cox, Hardwick, Abbott, Ragon, Christie; Nay: none

6. Public Comment Period Rod Hall, Chairman

No public comments were offered.

7. Board Member Comments and Reports Rod Hall, Chairman

Region 1: Mr. Kennedy stated it was good to be back in person.

Region 2: Ms. Cox announced that the Economic Development Strategic Planning Committee reconvened on March 11. There was a lot of discussion on the revenue-producing funding. She was glad to hear that the Department did not oppose revenue-generating projects but budget discourages the change. She noted that DOAV is looking at a request for funds for economic development related to aeronautics.

Region 3: Mr. Hardwick thanked DOAV, VAOC, and Ms. Ragon for the work on the *Airport Program Manual* updates and is looking forward to work going forward and the relationship with VAOC. He recognized the outstanding efforts with regard to setup to hold the meetings in the hangar.

Region 4: No report

Region 5: Ms. Ragon echoed Mr. Hardwick's remarks on the setup and *Airport Program Manual*. She thanked John Campbell for agreeing to speak to her Rotary Club in April.

Region 6: N/A

Region 7: Ms. Christie thanked everyone for the efforts in Region 7 as there has been a log of engagement. She also concurred with Mr. Hardwick's comments on setup for the meetings.

Director: No report

Chairman: The Chairman echoed Mr. Hardwick's comments. He thanked John Campbell for his assistance in the coordination with a school in his area with respect to careers in aviation. He congratulated sponsors across the Commonwealth on the passage of the economic recovery act, including one billion dollars for airport and airport concessionaires.

8. Adjournment

Rod Hall, Chairman

The Chairman entertained a motion to adjourn at 1:20 pm.

Motion to approve: Hardwick

Second: Cox

Vote: Aye: Kennedy, Cox, Hardwick, Abbott, Ragon, Christie; Nay: none

DRAFT

AMENDED ENTITLEMENT UTILIZATION PLANS			
SUMMARY OF NEW / AMENDED PROJECTS			
6/10/2021			
<u>AIRPORT / PROJECT</u>	<u>ENTITLEMENT AMOUNT</u>	<u>AMENDED FY2021 PLAN DOAV RECOMMENDATION</u>	<u>COMMENTS</u>
Charlottesville-Albemarle			
Modular Gate Area	\$160,000	Approve	
Lynchburg Regional			
North GA Development - Alternate 2 (Construction)	\$1,234,026	Approve	
North GA Development - Bid Additive 1 (Construction)	\$372,704	Approve	
North GA Development - Bid Additive 2 (Construction)	\$553,272	Approve	
North GA Development - Construction Management / Inspection	\$496,000	Approve	
North GA Development - Parking Lot / Access Road (Con)	\$1,280,000	Approve	
Portable Water-Filled Barricades	\$12,000	Approve	
Newport News/Williamsburg Int'l			
Fueling System Upgrade	\$33,000	Approve	
Mower - Boom Cutter Attachment	\$56,000	Approve	
Flight Information Display System (FIDS)	\$40,000	Approve	
Access Control System Replacement	\$40,000	Approve	
ARFF Station Expansion Joint Repairs	\$24,000	Approve	
GA Ramp Rehabilitation - (EA and Design)	\$160,000	Approve	
Shenandoah Valley Regional			
Air Carrier Terminal Building Boiler Replacement	\$24,975	Approve	
Runway Partial Remarketing	\$16,000	Approve	

Commonwealth Airport Fund
Entitlement Utilization Report and Plan

Sponsor: Charlottesville-Albemarle Airport Authority

Airport: Charlottesville-Albemarle Airport

Part 1 - Entitlement Utilization Report: FY2020

A. Entitlement Funds Available for Expenditure and Commitment

Funds Available for Commitment from FY2019	\$14,254,289.12
Entitlement Funds Received in FY2020	\$2,000,000.00
Interest Earned in FY2020	\$121,865.48
Subtotal Entitlement Resources Available FY2020	\$16,376,154.60

B. Reimbursement of State Entitlement Funds - PFC's; Bridge Loans; Other: FY2020

Project Description	Funding Sources with Final Costs					Total Project Cost	State Funding Percentage	Reimbursement
	Federal	State Entitlement	State Discretionary	PFC	Local			
Reimburse prorated share of Hangar Purchase in FY14 (was on last amended EUR)		\$72,356.00				\$ 72,356.00		
						-		
						-		
Subtotal PFCs Used to Reimburse State Entitlement Funds		\$72,356.00				\$ -		

Total Funds Available \$16,448,510.60

C. Funding Expenditures for Projects Closed: FY2020

Project Description	Funding Sources with Final Costs					Total Project Cost	State Funding Percentage	Estimated PFCs to Reimburse Entitlements
	Federal	State Entitlement	State Discretionary	PFC	Local			
RY19 Eligible Maint & Repair Projects (Unanticipated) Kaba Repair - \$21,455 less the \$14,210		\$ 5,796.00			\$ 1,449.00	\$ 7,245.00	80%	
AIP Air Carrier Ramp-North Expand & Lighting Upgrade Design	\$ 442,776.00	\$ 49,198.00			\$ -	\$ 491,974.00	10%	
Flight Information Display System Upgrade and Expansion/Public Announcement (PA) System Upgrade and Expansion (listed separately in FY18)		\$ 308,198.00			\$ 201,122.00	\$ 509,320.00	61%	
Charging Stations at Gate 5 Seating Area/and Gates 1-4 (listed separately in FY18)		\$ 303,999.00			\$ 76,000.00	\$ 379,999.00	80%	
FAA Reimbursable for MALSR Adjustments		\$ 74,939.00			\$ 18,735.00	\$ 93,674.00	80%	
De-ice tank for snow removal (6,000 gal)		\$ 44,835.00			\$ 11,209.00	\$ 56,044.00	80%	
Lower Level Business Center and Modify Gate 1 Security Exit		\$ 75,034.00			\$ 18,758.00	\$ 93,792.00	80%	
Business Center Phase II		\$ 60,852.00			\$ 15,213.00	\$ 76,065.00	80%	
Review of Terminal Structural Integrity and Utility Capacity		\$ 44,422.00			\$ 12,529.00	\$ 56,951.00	78%	
Vehicle Gate Installation at FBO		\$ 25,500.00			\$ 6,375.00	\$ 31,875.00	80%	
Friction Tester for Airfield		\$ 47,788.00			\$ 11,947.00	\$ 59,735.00	80%	
FY20 Eligible Repair & Maintenance (Unanticipated)		\$ 22,357.36			\$ 5,589.34	\$ 27,946.70	80%	
FY20 Escalator Repair & Maintenance 80/20		\$ 24,212.34			\$ 6,053.09	\$ 30,265.43	80%	
FY20 HVAC Repair & Maintenance 78/22		\$ 190,397.47			\$ 53,701.85	\$ 244,099.32	78%	

Commonwealth Airport Fund
Entitlement Utilization Report and Plan

FY20 Elevator Repair & Maintenance 80/20		\$ 40,554.73			\$ 10,138.68	\$ 50,693.41	80%	
FY20 Access Control Services 80/20		\$ 28,674.22			\$ 7,168.55	\$ 35,842.77	80%	
FY20 Rubber Removal/Ramp TW Repairs/Joint Seal, Markings		\$ 34,575.86			\$ 8,643.96	\$ 43,219.82	80%	
FY20 ARFF/Tractor/Snow removal/FOD Equipment (blades., wafer, tire replacement etc.)		\$ 51,437.52			\$ 12,859.38	\$ 64,296.90	80%	
Lift replacement Terminal		\$ 38,800.00			\$ 9,700.00	\$ 48,500.00	80%	

Subtotal Expenditures for Projects Completed: FY2020 \$1,471,570.50

Unexpended Funds Available for Commitment \$14,976,940.10

**Commonwealth Airport Fund
Entitlement Utilization Report and Plan**

Funding Commitments for Ongoing Projects

Project Description	Estimated Fiscal Year of Completion	Funding Sources with Estimated Costs					Estimated Total Project Cost	Estimated State Funding Percentage	Estimated PFCs to Reimburse Entitlements
		Federal	State Entitlement	State Discretionary	PFC	Local			
Terminal Expansion Project (project complete, need financial closeout)	2020		\$1,172,205.00	\$2,697,582.00	\$73,504.00	\$380,493.00	\$ 4,323,784.00	89.5%	\$1,172,205.00
Terminal Expansion Project costs overrun awaiting approval	2020		\$652,112.00			\$76,505.00	\$ 728,617.00	89.5%	\$652,112.00
RW 3-21 Overlay Construction	2020	\$11,872,035.00	\$1,319,116.00				\$ 13,191,151.00	10.0%	\$1,319,116.00
AIP Air Carrier Ramp - North & Ramp Lighting Upgrade Construction (and ALP Update)	2021	\$3,690,181.00	\$410,020.00			\$0.00	\$ 4,100,201.00	10.0%	\$410,020.00
Non-AIP Air Carrier Ramp - North & Ramp Light Upgrade Const	2021		\$3,806,383.00			\$951,596.00	\$ 4,757,979.00	80.0%	\$3,806,383.00
Escalators Replacement at Gate 5	2021		\$640,000.00			\$160,000.00	\$ 800,000.00	80.0%	\$640,000.00
Gutter Replacement ARFF building	2020		\$12,800.00			\$3,200.00	\$ 16,000.00	80.0%	\$12,800.00
Escalators Replacement at Gate 1A	2021		\$640,000.00			\$160,000.00	\$ 800,000.00	80.0%	\$640,000.00
Terminal & Landside Wayfinding & passenger amenities	2021		\$160,000.00			\$40,000.00	\$ 200,000.00	80.0%	\$160,000.00
Green Initiative - Window energy tinting/modifications	2020		\$80,000.00			\$20,000.00	\$ 100,000.00	80.0%	\$80,000.00
Security System Update Phase 2	2020		\$80,000.00			\$20,000.00	\$ 100,000.00	80.0%	\$80,000.00
Air Carrier Ramp Passenger Walkways	2020	\$1,980,000.00	\$620,000.00			\$100,000.00	\$ 2,700,000.00	23.0%	\$620,000.00
Emergency Generator Phase 1	2020		\$320,000.00			\$80,000.00	\$ 400,000.00	80.0%	\$320,000.00
Terminal Technology upgrade (PY 2 line items)	2020		\$152,000.00			\$38,000.00	\$ 190,000.00	80.0%	\$152,000.00
GA Ramp Improvements	2021		\$400,000.00			\$100,000.00	\$ 500,000.00	80.0%	\$400,000.00
Inbound Bag Belt Replacement (Baggage Claim)	2020		\$400,000.00			\$100,000.00	\$ 500,000.00	80.0%	\$400,000.00
MALSR Engineering Design and Repair Fees	2020		\$326,400.00		\$81,600.00		\$ 408,000.00	80.0%	\$326,400.00
Upgrade Lighting	2020		\$7,800.00			\$1,950.00	\$ 9,750.00	80.0%	\$7,800.00
Radio update - CHO's portion of Region-wide project	2021		\$276,480.00		\$69,120.00		\$ 345,600.00	80.0%	\$276,480.00
Terminal Expansion Design	2021		\$640,000.00		\$160,000.00		\$ 800,000.00	80.0%	\$640,000.00
Big Fans for terminal concourse	2020		\$72,000.00			\$18,000.00	\$ 90,000.00	80.0%	\$72,000.00
Entrance Door Replacements (3 sets)	2020		\$120,000.00		\$30,000.00		\$ 150,000.00	80.0%	\$120,000.00
Air Carrier Ramp Remarketing Project (Design/ Eradication/Re-marking/Inspections)	2021		\$160,000.00			\$40,000.00	\$ 200,000.00	80.0%	\$160,000.00
Fence Improvements	2020		\$32,000.00			\$8,000.00	\$ 40,000.00	80.0%	\$32,000.00
Obstruction Removal as identified by FAA	2020		\$160,000.00			\$40,000.00	\$ 200,000.00	80.0%	\$160,000.00
Snow Removal Equipment Storage Shop Improvements	2020		\$240,000.00			\$60,000.00	\$ 300,000.00	80.0%	\$240,000.00
Remote Control Steep Slope Mower	2020		\$64,000.00			\$16,000.00	\$ 80,000.00	80.0%	\$64,000.00
Rehab Public Elevator at Gate 5	2020		\$20,000.00			\$5,000.00	\$ 25,000.00	80%	\$20,000.00
Out Bound Baggage Belt	2020		\$160,000.00		\$40,000.00		\$ 200,000.00	80%	\$160,000.00
Repayment of 3 VDOA Bridge Loans (Lad, EA, Obstructions)	2021	\$685,339.00	\$76,149.00				\$ 761,488.00	10%	\$76,149.00
Purchase 2 airfield Ventrac Mowers	2020		\$52,000.00			\$13,000.00	\$ 65,000.00	80%	\$52,000.00
Terminal Technology to inc IT room modification	2021		\$160,000.00			\$40,000.00	\$ 200,000.00	80%	\$160,000.00
Paint Interior of Terminal	2020		\$80,000.00			\$20,000.00	\$ 100,000.00	80%	\$80,000.00
Clean and recaulk exterior of terminal	2020		\$78,000.00			\$22,000.00	\$ 100,000.00	78%	\$78,000.00

**Commonwealth Airport Fund
Entitlement Utilization Report and Plan**

Airfield Pre&Post Emergent Application	2020		\$32,000.00			\$8,000.00	\$ 40,000.00	80%	\$32,000.00
Paint Exterior of ARFF Building	2020		\$32,000.00			\$8,000.00	\$ 40,000.00	80%	\$32,000.00
Terminal Gutter Installation	2020		\$39,000.00			\$11,000.00	\$ 50,000.00	78%	\$39,000.00
800 MHZ Radio System Emergency Response - equipment upgrade	2020		\$60,000.00			\$15,000.00	\$ 75,000.00	80%	\$60,000.00
Airport-Wide Security Upgrade Phase 1 - requires letter from TSA 1542	2021	\$800,000.00	\$100,000.00				\$ 900,000.00	11%	\$100,000.00
SRE Storage Structure	2020		\$240,000.00			\$60,000.00	\$ 300,000.00	80%	\$240,000.00
Bucket Truck	2020		\$88,000.00			\$22,000.00	\$ 110,000.00	80%	\$88,000.00
Land Acquisition for Runway Protection	2021		\$720,000.00			\$180,000.00	\$ 900,000.00	80%	\$720,000.00
Mechanic Equipment Lift	2020		\$40,000.00			\$10,000.00	\$ 50,000.00	80%	\$40,000.00
Replace ARFF Roof	2021		\$160,000.00			\$40,000.00	\$ 200,000.00	80%	\$160,000.00
ARFF Building Rehab Phase 1	2021		\$160,000.00			\$40,000.00	\$ 200,000.00	80%	\$160,000.00
FY21 Unanticipated eligible repair & maint	2021		\$80,000.00			\$20,000.00	\$ 100,000.00	80.0%	\$80,000.00
FY 21 Escalator Maint/repair	2021		\$16,000.00			\$4,000.00	\$ 20,000.00	80.0%	\$16,000.00
FY 21 HVAC Maintenance & Repairs	2021		\$117,000.00			\$33,000.00	\$ 150,000.00	78.0%	\$117,000.00
FY21 Elevator Maintenance & Repairs	2021		\$20,000.00			\$5,000.00	\$ 25,000.00	80.0%	\$20,000.00
FY21 Access Control Maintenance & Repairs	2021		\$32,000.00			\$8,000.00	\$ 40,000.00	80.0%	\$32,000.00
FY 21 Rubber removal/ Ramp Joint Seal/Airfield Marking/pavement repair/ nav aid maint projects and airfield signage repair/replacement as identified by Part 139 inspection	2021		\$64,000.00			\$16,000.00	\$ 80,000.00	80.0%	\$64,000.00
FY21 KABA Exit Lane System and Automated Doors Maintenance & Repairs	2021		\$60,000.00			\$15,000.00	\$ 75,000.00	80.0%	\$60,000.00
FY21 ARFF/Tractors/Snow Removal Equipment - blades, wafer, tire replacement, etc.	2021		\$64,000.00			\$16,000.00	\$ 80,000.00	80.0%	\$64,000.00
FY21 Generator Maintenance & Repairs	2021		\$19,500.00			\$5,500.00	\$ 25,000.00	78.0%	\$19,500.00
FY21 Plumbing System Repairs & Maintenance	2021		\$19,500.00			\$5,500.00	\$ 25,000.00	78.0%	\$19,500.00
FY21 Fire Control System Maintenance & Repairs	2021		\$19,500.00			\$5,500.00	\$ 25,000.00	78.0%	\$19,500.00
FY21 Jet bridge and Mobile Passenger Ramps Maintenance & Repairs	2021		\$32,000.00			\$8,000.00	\$ 40,000.00	80.0%	\$32,000.00
Terminal Ceiling Tile Replacement - material only / labor provided in-house	2021		\$25,000.00			\$0.00	\$ 25,000.00	100.0%	\$25,000.00
ARFF Building Phase 2- Rehab/Mitigation	2021		\$160,000.00			\$40,000.00	\$ 200,000.00	80.0%	\$160,000.00
Install Guard Rail Along Bowen Loop near Basin	2021		\$20,000.00			\$5,000.00	\$ 25,000.00	80.0%	\$20,000.00
Recondition Terrazzo	2021		\$120,000.00			\$30,000.00	\$ 150,000.00	80.0%	\$120,000.00
Replace 1990 Airfield Bush hog & Tractor	2021		\$64,000.00			\$16,000.00	\$ 80,000.00	80.0%	\$64,000.00
Terminal Technology	2021		\$40,000.00			\$10,000.00	\$ 50,000.00	80.0%	\$40,000.00
Rehab Bricks and Concrete on Curbside	2021		\$80,000.00			\$20,000.00	\$ 100,000.00	80.0%	\$80,000.00
Asphalt Crack Seal Equipment	2021		\$68,000.00			\$17,000.00	\$ 85,000.00	80.0%	\$68,000.00
SRE Mechanical Equipment Lift	2021		\$40,000.00			\$10,000.00	\$ 50,000.00	80.0%	\$40,000.00
Replace 1986 Runway/Taxiway De-icer	2021	\$ 180,000.00	\$20,000.00				\$ 200,000.00	10.0%	\$20,000.00
Terminal Area Plan (for expense incurred after approval date of EUR)	2021		\$350,000.00		\$ 350,000.00		\$ 700,000.00	50.0%	\$350,000.00

\$16,790,965.00

Subtotal Funding Commitments for Ongoing Projects

\$16,790,965.00

Commonwealth Airport Fund
Entitlement Utilization Report and Plan

Anticipated FY2021 Entitlement Funds (use last year's amount) \$2,000,000.00

Funds Available \$185,975.10

Part 2 - Entitlement Utilization Plan: FY2021

Project Listing

EUP #	Project Description	6-Year Plan Y / N	Estimated Start Date (Fiscal Year)	Funding Sources with Estimated Costs					Estimated Total Project Cost	Estimated State Funding Percentage	Estimated PFCs to Reimburse Entitlements	
				Federal	State Entitlement	State Discretionary	PFC	Local				
1	Modular Gate Area	Y	2022		\$160,000.00			\$40,000.00	\$200,000.00	0.8	\$160,000.00	
2	Replace 1986 Runway/Taxiway De-icer	Y	2022	-180000	-\$20,000.00				-\$200,000.00	0.1	-\$20,000.00	
Total Planned Commitments for Future Projects				\$140,000.00								

Funds Available \$45,975.10

**Commonwealth Airport Fund
Entitlement Utilization Report and Plan**

Project Narratives

EUP #	Narrative
1	Modular Gate Area -During the Escalator Replacement project, we will need to relocate the American Airline passengers from the second floor Gate 5 to a modular gate area (25'x75") to be located on the ramp near Gate 1
2	Replace 1986 Runway/Taxiway De-icer - FAA is funding the project at 100% participation

Part 3 - Certification

As the Executive Director on behalf of the sponsor, I certify that the information provided above is accurate and complete to the best of my knowledge.

Melinda C Crawford
Signature

Melinda C. Crawford
Printed Name

5-17-2021
Date

As the Chief Financial Officer on behalf of the sponsor, I certify that the information provided above is accurate and complete to the best of my knowledge.

Penny Shifflett
Signature

Penny Shifflett
Printed Name

5-17-2021
Date



**Commonwealth Airport Fund
Entitlement Utilization Report and Plan**

Sponsor: City of Lynchburg

Airport: Lynchburg Regional Airport

Part 1 - Entitlement Utilization Report: FY2020

A. Entitlement Funds Available for Expenditure and Commitment

Total Funds Available for Commitment from FY2019	\$4,569,190.82
Entitlement Funds Received in FY2020	\$1,703,932.09
Interest Earned in FY2020	\$37,650.41
 Subtotal Entitlement Resources Available FY2020	 \$6,310,773.32

B. Reimbursement of State Entitlement Funds - PFC's; Bridge Loans; Other: FY2020

Project Description	AIP Project Number	DOAV Project Number	PFC Project Number	Funding Sources with Final Costs					Total Project Cost	State Funding Percentage	Reimbursement
				Federal	State Entitlement	State Discretionary	PFC	Local			
no activity in FY2020									\$ -		
									\$ -		

Subtotal Reimbursement of State Entitlement Funds \$0.00

Total Funds Available \$6,310,773.32 (Entitlement Resources Available FY2020 + Reimbursement State Entitlement Funds)

C. Funding Expenditures for Projects Closed: FY2020

Project Description	AIP Project Number	DOAV Project Number	PFC Project Number	Funding Sources with Final Costs					Total Project Cost	State Funding Percentage	Estimated PFCs to Reimburse Entitlements
				Federal	State Entitlement	State Discretionary	PFC	Local			
Air Traffic Control Tower (new) Reimbursable Agreements	3-51-0029-038			\$23,410.00	\$58,156.82				\$ 581,566.82	10%	
Rehabilitate Perimeter Road		EUR18-008			\$35,780.00			\$8,945.00	\$ 44,725.00	80%	
Rehabilitate T-hangar Taxi-lane		EUP18-009			\$15,988.00			\$3,997.00	\$ 19,985.00	80%	
Asphalt Patch & Apron tie-in (approved as bucket item)		EUP18-014			\$5,108.00			\$1,277.00	\$ 6,385.00	80%	
Air Carrier Apron Parking Position Pavement Evaluation		EUP19-017			\$17,968.93			\$4,492.23	\$ 22,461.16	80%	
Articulated Boom Lift		EUP20-001			\$57,599.00			\$14,399.83	\$ 71,998.83	80%	
Terminal Public Address System Upgrade		EUP20-003			\$26,048.30			\$6,512.07	\$ 32,560.37	80%	
MUFIDS Service Agreement (annual)		EUP20-004			\$5,745.60			\$1,436.40	\$ 7,182.00	80%	
Mower Replacement		EUP20-005			\$24,990.40			\$6,247.60	\$ 31,238.00	80%	
MidField GA Ramp Lighting		EUP20-007			\$22,000.00			\$5,500.00	\$ 27,500.00	80%	
Terminal Interior Lighting Upgrade to LED		EUP20-009			\$40,895.42			\$10,223.86	\$ 51,119.28	80%	
Terminal HVAC Vents Replacement		EUP20-012			\$832.32			\$208.08	\$ 1,040.40	80%	
Security Pedestrian Gate MidField Ramp		EUP20-013			\$716.00			\$179.00	\$ 895.00	80%	
Terminal Utility Service Upgrade (55% public space)		EUP20-014			\$4,119.42			\$3,370.43	\$ 7,489.85	55%	
Generator Service Agreements (annual)		EUP20-016			\$4,176.61			\$1,044.15	\$ 5,220.76	80%	
HVAC Service Agreement (55% public space, annual)		EUP20-017			\$8,025.60			\$6,566.40	\$ 14,592.00	55%	
Elevator/Escalator Service Agreement (annual)		EUP20-018			\$5,635.20			\$1,408.80	\$ 7,044.00	80%	
ATCT Equipment Service Agreements (annual)		EUP20-019			\$20,777.13			\$5,194.29	\$ 25,971.42	80%	
Security Technology/Perimeter (various) item 1 - replace main terminal camera		EUP20-020			\$2,934.16			\$733.54	\$ 3,667.70	80%	
Security Technology/Perimeter (various) item 2 - replace security computer		EUP20-020			\$494.59			\$123.64	\$ 618.23	80%	
Security Technology/Perimeter (various) item 3 - update security computer software		EUP20-020			\$800.00			\$200.00	\$ 1,000.00	80%	
Security Technology/Perimeter (various) item 4 - install new security computer		EUP20-020			\$380.00			\$95.00	\$ 475.00	80%	
Security Technology/Perimeter (various) item 5 - install 4 new ATCT rooftop cameras		EUP20-020			\$17,446.06			\$4,361.52	\$ 21,807.58	80%	
Facility Maintenance (various) 1 item - ARFF bldg replace controllers/sensors		EUP20-022			\$7,160.00			\$1,790.00	\$ 8,950.00	80%	
Water Bottle Filling Station		EUP20-029			\$2,358.34			\$589.58	\$ 2,947.92	80%	

Subtotal Expenditures for Projects Completed: FY2020 \$386,135.90 (State Entitlement Funds)

Unexpended Funds Available for Commitment \$5,924,637.42 (Total Funds Available - Expenditures for Completed Projects)

**Commonwealth Airport Fund
Entitlement Utilization Report and Plan**

D. Funding Commitments for Ongoing Projects

Project Description	Estimated Fiscal Year of Completion	AIP Project Number	DOAV Project Number	PFC Project Number	Funding Sources with Estimated Costs					Estimated Total Project Cost	Estimated State Funding Percentage	Estimated PFCs to Reimburse Entitlements
					Federal	State Entitlement	State Discretionary	PFC	Local			
North General Aviation (GA) Dev. Area Ph1 Sitework (AIP eligible)	FY21	3-51-0029-040	EUP18-013		\$517,950.00	\$57,550.00				\$ 575,500.00	10%	
North General Aviation (GA) Dev. Area Ph1 Sitework (non AIP)	FY21		EUP18-013			\$219,600.00			\$54,900.00	\$ 274,500.00	80%	
Hangar 6 Apron Concrete Slab Rehabilitation	FY21		EUP18-019			\$7,200.00			\$1,800.00	\$ 9,000.00	80%	
Detention Pond Drainage Structure Repair	FY21		EUP18-023			\$14,400.00			\$3,600.00	\$ 18,000.00	80%	
Passenger Terminal Boarding Bridge (revised Feb 2020)	FY21	3-51-0029-041	EUP18-025		\$540,000.00	\$60,000.00				\$ 600,000.00	10%	
Passenger Terminal Restroom Renovation	FY21		EUP19-011			\$80,000.00			\$20,000.00	\$ 100,000.00	80%	
Aircraft Self-Service AVGAS Fueling Facility (33.3% - \$75k max)	FY21		EUP19-014			\$75,000.00			\$150,000.00	\$ 225,000.00	(\$75k max)	
Business Center	FY21		EUP19-015			\$80,000.00			\$20,000.00	\$ 100,000.00	80%	
Rehab Mid-Field Apron & Portion of Taxiway G (100% Fed - DELETE)	FY21	3-51-0029-042	EUP19-019		\$2,000,000.00	\$0.00				\$ 2,000,000.00	0%	
Terminal Drive & Crosswalks crackseal/sealcoat	FY21		EUP20-002			\$16,000.00			\$4,000.00	\$ 20,000.00	80%	
Passenger Terminal Landscaping / Tree Replacement	FY21		EUP20-006			\$40,000.00			\$10,000.00	\$ 50,000.00	80%	
Terminal Exit Lane Modification	FY21		EUP20-010			\$1,200,000.00				\$ 1,200,000.00	100%	
TSA Baggage Screening Counter Modifications	FY21		EUP20-015			\$120,000.00			\$30,000.00	\$ 150,000.00	80%	
Air Carrier Apron Parking Position Hardstands	FY21		EUP20-026			\$40,000.00			\$10,000.00	\$ 50,000.00	80%	
N. General Aviation (GA) Dev. Area Ph2, Design (100% Fed - DELETE)	FY21	3-51-0029-042	EUP20-027		\$350,000.00	\$0.00				\$ 350,000.00	0%	
Passenger Terminal Boarding Bridge (non-AIP) additional	FY21	3-51-0029-041	EUP20-028		\$203,992.00	\$161,008.00			\$35,000.00	\$ 400,000.00	varies	
SWPPP, SPCC, & ODC Plan updated	FY21		EUP20-030			\$16,000.00			\$4,000.00	\$ 20,000.00	80%	
Equipment Maintenance/Repair (annual bucket) (REDUCED)	FY21		EUP21-001			\$8,000.00			\$2,000.00	\$ 10,000.00	80%	
Equipment Purchases (annual bucket) DELETED												
Facility Maintenance/Repair (annual bucket) (REDUCED)	FY21		EUP21-003			\$8,000.00			\$2,000.00	\$ 10,000.00	80%	
Pavements Repair/Rehabilitation (annual bucket) (REDUCED)	FY21		EUP21-004			\$20,000.00			\$5,000.00	\$ 25,000.00	80%	
Pavement Markings (annual bucket) (REDUCED)	FY21		EUP21-005			\$8,000.00			\$2,000.00	\$ 10,000.00	80%	
ATCT Equipment Service Agreements/Maintenance	FY21		EUP21-006			\$24,000.00			\$6,000.00	\$ 30,000.00	80%	
MUFIDS Annual Service Agreement	FY21		EUP21-007			\$6,000.00			\$1,500.00	\$ 7,500.00	80%	
Riding Slope Mower	FY21		EUP21-008			\$48,000.00			\$12,000.00	\$ 60,000.00	80%	
Cyberlock Security System	FY21		EUP21-009			\$40,000.00			\$10,000.00	\$ 50,000.00	80%	
Terminal Exit Lane Modification (increase to \$2,000,000)	FY21		EUP21-010			\$800,000.00				\$ 800,000.00	100%	
Amendment - Project added Dec 2020 VAB meeting approved												
Aircraft Parking Position Hardstands (increase to EUP20-026)	FY21		EUP21-011			\$140,000.00			\$35,000.00	\$ 175,000.00	80%	
										\$ -		

Subtotal Funding Commitments for Ongoing Projects	\$3,288,758.00	(State Entitlement Funds)
Anticipated FY2021 Entitlement Funds (received YTD FY2021)	\$1,470,268.01	
Funds Available	\$4,106,147.43	(Unexpended Funds Available for Commitment - Funding Commitments for Ongoing Projects + Anticipated FY2021 Entitlement Funds)

**Commonwealth Airport Fund
Entitlement Utilization Report and Plan**

Part 2 - Entitlement Utilization Plan: FY2021

A. Project Listing

EUP #	Project Description	6-Year Plan Y / N	Estimated Start Date (Fiscal Year)	AIP Project Number	DOAV Project Number	PFC Project Number	Funding Sources with Estimated Costs					Estimated Total Project Cost	Estimated State Funding Percentage	Estimated PFCs to Reimburse Entitlements	
							Federal	State Entitlement	State Discretionary	PFC	Local				
12a	No.GA Devel. Area Ph2, Construction (Alternate 2)	Y	FY21	pending			\$3,082,588.00	\$0.00				\$ 3,082,588.00	0%		
12b	No.GA Devel. Area Ph2, Constr (Alt 2 - Insufficient AIP)	Y	FY21					\$1,234,026.00				\$308,506.00	\$ 1,542,532.00	80%	
12c	No.GA Devel. Area Ph2, Constr (Bid Add1 non-AIP 50')	Y	FY21					\$372,704.00				\$93,176.00	\$ 465,880.00	80%	
12d	No.GA Devel. Area Ph2, Constr (Bid Add2 non-AIP 150')	Y	FY21					\$553,272.00				\$138,318.00	\$ 691,590.00	80%	
12e	No.GA Devel. Area Ph2, Constr (Admin/Inspections)	Y	FY21					\$496,000.00				\$124,000.00	\$ 620,000.00	80%	
12f	No.GA Devel. Area Ph2, Constr (Parking/Access non-AIP)	Y	FY22					\$1,280,000.00				\$320,000.00	\$ 1,600,000.00	80%	
13	Water Barricades	N	FY21					\$12,000.00				\$3,000.00	\$ 15,000.00	80%	
												\$ -			
												\$ -			
												\$ -			
												\$ -			
												\$ -			

Total Planned Commitments for Future Projects \$3,948,002.00 (State Entitlement Funds)

Funds Available \$158,145.43

B. Project Narratives

EUP #	Narrative
12a	Project 12 includes construction/admin/inspection of an approximately 100,000 sf apron in the "North GA Development Area" with a connecting taxiway and relocation of a portion of the airport service road. Project 12a assumes only an estimated \$3,082,588 in Federal AIP funding will be available for this project at 100% funding (for AIP grants funded in federal FY 2021). This does not include the first 50' of pavement strip from the hangar site.
12b	Project 12b will complete the "Insufficient AIP funding" for project 12a/b with 80% state and 20% local funding. Total apparent low bid for Alternate #2 is \$4,625,120.
12c	Project 12c (Bid Additive 1) is the portion of the apron that extends 50' from the hangar site (non-AIP eligible).
12d	Project 12d (Bid Additive 2) would extend the apron area by 150' to the north of the AIP-eligible apron area.
12e	Project 12e (Construction Admin/Inspections) would provide for on-site engineering oversight of the construction to ensure quality standards are met
12f	Project 12f includes landside development of public parking (approx. 75 spaces) and access roads to the site
13	Low profile Water Barricades would be used for a variety of upcoming projects as well as special events. Estimated cost of 50 6' units with flags and lighting and shipping is estimated at \$15,000.

Commonwealth Airport Fund
Entitlement Utilization Report and Plan

Part 3 - Certification

As the Executive Director on behalf of the sponsor, I certify that the information provided above is accurate and complete to the best of my knowledge.

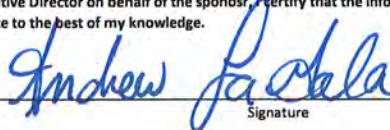

Signature

Andrew LaGala, Airport Director
Printed Name

"May 17, 2021 (revised)"
Date

As the Chief Financial Officer on behalf of the sponsor, I certify that the information provided above is accurate and complete to the best of my knowledge.



Signature

Catherine C. Vance, Assistant Airport Director, Finance & Administration
Printed Name

"May 17, 2021 (revised)"
Date

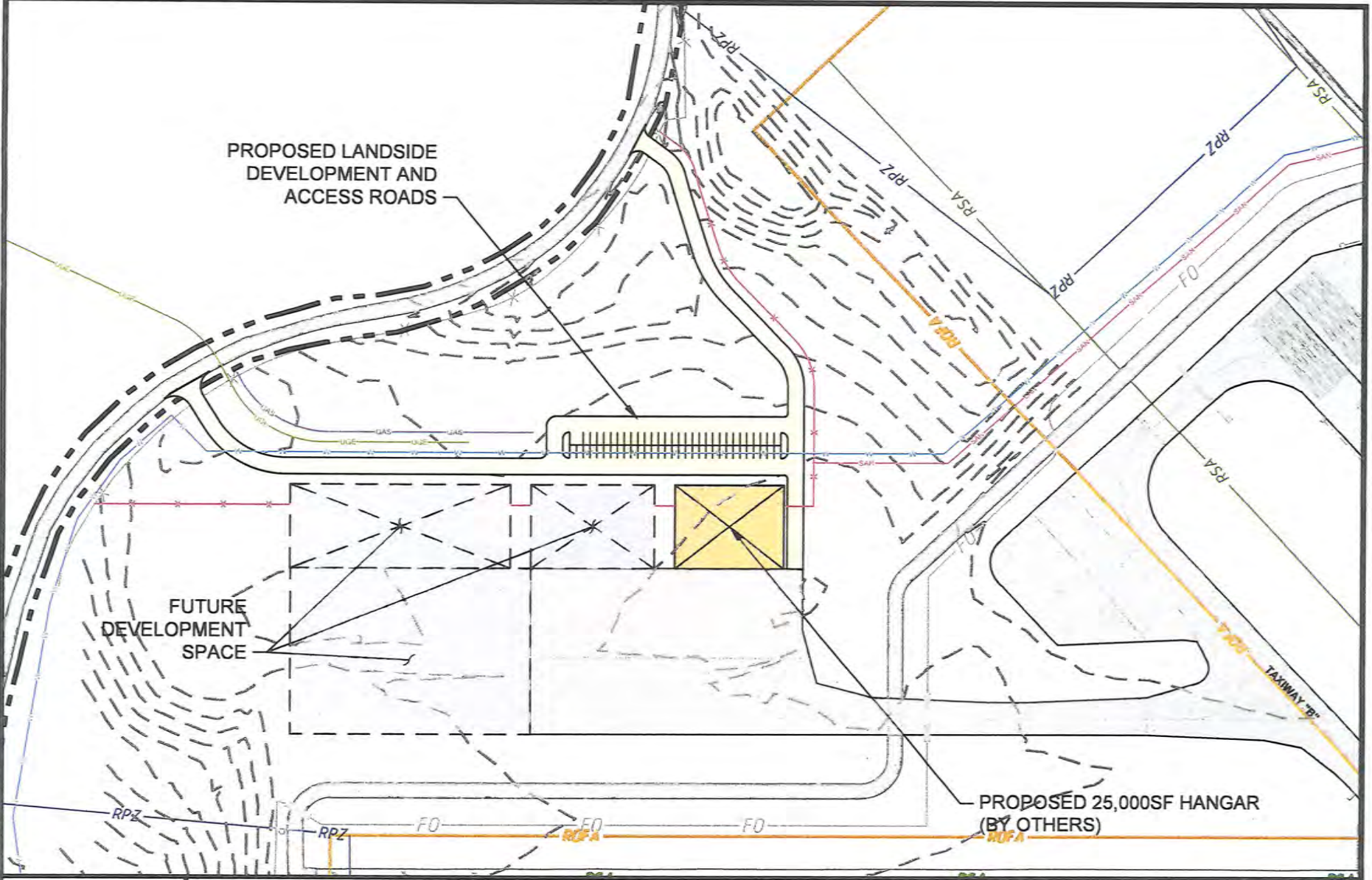

Exhibit 12F, page 2

 <p>www.deltaairport.com</p>	<p>PROPOSED NORTH GA LANDSIDE DEVELOPMENT LYNCHBURG REGIONAL AIRPORT</p>				<p>EXHIBIT 12F</p>		
DRAWN BY:	TLB	CHECKED BY:	TLB	SCALE:	1" = 200'	DATE:	MARCH 2021



**Commonwealth Airport Fund
Entitlement Utilization Report and Plan**

Sponsor: Peninsula Airport Commission

Airport: Newport News/Williamsburg International Airport

Part 1 - Entitlement Utilization Report: FY2020

A. Entitlement Funds Available for Expenditure and Commitment

Total Funds Available for Commitment from FY2019	\$6,312,064.55
Entitlement Funds Received in FY2020	\$2,000,000.00
Interest Earned in FY2020	\$30,409.99
 Subtotal Entitlement Resources Available FY2020	 \$8,342,474.54

B. Reimbursement of State Entitlement Funds - PFC's; Bridge Loans; Other: FY2020

Project Description	AIP Project Number	DOAV Project Number	PFC Project Number	Funding Sources with Final Costs					Total Project Cost	State Funding Percentage	Reimbursement
				Federal	State Entitlement	State Discretionary	PFC	Local			
None									\$ -		

Subtotal Reimbursement of State Entitlement Funds \$0.00

Total Funds Available \$8,342,474.54 (Entitlement Resources Available FY2020 + Reimbursement State Entitlement Funds)

C. Funding Expenditures for Projects Closed: FY2020

Project Description	AIP Project Number	DOAV Project Number	PFC Project Number	Funding Sources with Final Costs					Total Project Cost	State Funding Percentage	Estimated PFCs to Reimburse Entitlements
				Federal	State Entitlement	State Discretionary	PFC	Local			
Air Handler Reheat Coil - AHU #3					\$2,668.80			\$4,003.20	\$ 6,672.00	40%	
Boiler Pump & Motor					\$2,768.62				\$ 2,768.62	100%	
Airfield Lighting Vault HVAC					\$1,046.82			\$261.70	\$ 1,308.52	80%	
Airfield Lighting, Globes, Gaskets, Signage Panels, Windssocks					\$2,539.41			\$579.42	\$ 3,118.83	81%	
Airfield Paint and Glass Beads					\$11,493.78				\$ 11,493.78	100%	
Airfield PAPI, Gaskets, Filters					\$1,704.03				\$ 1,704.03	100%	
Airfield Sign Panels					\$10,201.61			\$2,550.40	\$ 12,752.01	80%	
Airfield Signs LED Upgrade					\$774.56				\$ 774.56	100%	
Airport Beacon Replacement					\$66,600.00			\$16,650.00	\$ 83,250.00	80%	
Annual Maintenance and Inspection of Boilers/Chillers/Cooling Towers					\$4,257.60			\$6,386.40	\$ 10,644.00	40%	
Awning Repair					\$1,987.90			\$2,981.85	\$ 4,969.75	40%	
Bag Claim #2 Upper and Lower Wheel Replacement					\$5,801.07			\$1,450.27	\$ 7,251.34	80%	
Bobcat Track Replacement					\$2,708.76				\$ 2,708.76	100%	
Bond Debt South Corporate					\$154,552.60				\$ 154,552.60	100%	
Capacitor Bank for RWY 2/20					\$854.06				\$ 854.06	100%	
Cooling Tower Waterline Replacement					\$4,670.50			\$7,005.75	\$ 11,676.25	40%	
Elevator Conc A Power Supply					\$592.40			\$888.60	\$ 1,481.00	40%	

**Commonwealth Airport Fund
Entitlement Utilization Report and Plan**

EQ #55 Mower Deck Clutch					\$1,311.45				\$ 1,311.45	100%	
EQ#19 Replace Univ Joint					\$949.59				\$ 949.59	100%	
Escalator and Elevator Inspection and Maintenance					\$5,070.00			\$1,267.50	\$ 6,337.50	80%	
Firehouse Rooftop HVAC					\$1,584.00			\$396.00	\$ 1,980.00	80%	
Incoming Baggage Roll-up Door					\$1,760.00			\$440.00	\$ 2,200.00	80%	
JD #5 Flexwing Gear Case					\$1,304.30				\$ 1,304.30	100%	
John Deere 1545 Blower & Plow					\$32,972.02			\$8,243.00	\$ 41,215.02	80%	
John Deere 6135 Airfield Tractor					\$59,565.51			\$14,891.38	\$ 74,456.89	80%	
Lighted X #2 Diesel Generator					\$1,618.18			\$404.54	\$ 2,022.72	80%	
Lighted X Actuator Replacement					\$1,398.40			\$349.60	\$ 1,748.00	80%	
Load Bank Airfield Generator					\$1,551.76			\$387.94	\$ 1,939.70	80%	
Main Terminal Roof Repair Phase 1					\$25,802.72			\$38,704.08	\$ 64,506.80	40%	
Main Terminal Roof Study					\$4,948.00			\$7,422.00	\$ 12,370.00	40%	
Mower Blades and Mower Deck					\$2,955.34				\$ 2,955.34	100%	
Perimeter Fence Post Repair					\$2,141.60			\$535.40	\$ 2,677.00	80%	
Perimeter Road Approach End Runway 2 and 7 Design	3-51-0035-050-2018			279,577.24	\$30,689.14			\$375.00	\$ 310,641.38	10%	
Qtrly Fire Sprinkler Suppression Tests & Inspections					\$1,824.00			\$2,736.00	\$ 4,560.00	40%	
R3 Water Pump					\$541.16				\$ 541.16	100%	
Repair Fire Alarm/Sprinkler System					\$4,652.31			\$6,978.48	\$ 11,630.79	40%	
Snow Plow vehicles and plows (2)					\$53,952.80			\$13,488.20	\$ 67,441.00	80%	
Sweepster Lighted X Marker Actuator					\$1,748.00				\$ 1,748.00	100%	
Tractor #66 PTO Repair					\$2,577.84			\$681.51	\$ 3,259.35	79%	

Subtotal Expenditures for Projects Completed: FY2020 \$516,140.64 (State Entitlement Funds)

Unexpended Funds Available for Commitment \$7,826,333.90 (Total Funds Available - Expenditures for Completed Projects)

D. Funding Commitments for Ongoing Projects

Project Description	Estimated Fiscal Year of Completion	AIP Project Number	DOAV Project Number	PFC Project Number	Funding Sources with Estimated Costs					Estimated Total Project Cost	Estimated State Funding Percentage	Estimated PFCs to Reimburse Entitlements
					Federal	State Entitlement	State Discretionary	PFC	Local			
10K Loader	2021					\$136,000.00			\$34,000.00	\$ 170,000.00	80%	
Airfield Lighting, Globes, Gaskets, Signage Panels, Windsocks	2021					\$16,000.00			\$4,000.00	\$ 20,000.00	80%	
Airfield paint removal, painting and crack sealing	2021					\$60,000.00			\$15,000.00	\$ 75,000.00	80%	
Annual and Quarterly Fire Sprinkler and Suppression Inspections	2021					\$2,024.00			\$3,036.00	\$ 5,060.00	40%	
Annual Maintenance and Inspection of Boilers/Chillers/Cooling Towers	2021					\$4,877.00			\$7,315.00	\$ 12,192.00	40%	
South Corp Apron Rehabilitation Design and Bidding	2021			6.1		\$180,000.00		\$45,000.00		\$ 225,000.00	80%	
ARFF Tires Rescue 1	2021					\$12,000.00			\$3,000.00	\$ 15,000.00	80%	
Bond Debt South Corporate	2021					\$155,000.00				\$ 155,000.00	100%	
Construction Txy A Lighting, Shoulders & Realignment of Txys B & C	2021				\$5,320,777.00					\$ 5,320,777.00	0%	
Design Baggage Claim Rehabilitation	2021			6.3		\$240,000.00		\$60,000.00		\$ 300,000.00	80%	
Drainage Repair G Avenue	2021					\$11,000.00				\$ 11,000.00	100%	
Escalator and Elevator Inspection and Maintenance	2021					\$8,400.00			\$2,100.00	\$ 10,500.00	80%	
Facility Infrastructure and Equipment Repairs and Maintenance	2021					\$160,000.00			\$40,000.00	\$ 200,000.00	80%	
Firehouse Generator	2021					\$60,000.00			\$15,000.00	\$ 75,000.00	80%	

**Commonwealth Airport Fund
Entitlement Utilization Report and Plan**

Firehouse Roof Repair Phase 2	2021					\$32,000.00			\$8,000.00	\$ 40,000.00	80%	
FOD Boss	2021					\$8,000.00			\$2,000.00	\$ 10,000.00	80%	
JLG or similar Lift	2021					\$20,000.00			\$5,000.00	\$ 25,000.00	80%	
Main Terminal Roof Repair Phase 1	2021					\$30,000.00			\$45,000.00	\$ 75,000.00	40%	
Obstruction Survey	2021					\$80,000.00			\$20,000.00	\$ 100,000.00	80%	
Perimeter Road Approach End Runway 2 and 7 Construction	2021	3-51-0035-051-2019				\$2,834,100.00				\$ 3,149,000.00	10%	
Replacement Incoming Bag Belt Systems Phase 1	2023				6.3	\$720,000.00		\$180,000.00		\$ 900,000.00	80%	
Replacement Incoming Bag Belt Systems Phase 2	2024				6.3	\$720,000.00		\$180,000.00		\$ 900,000.00	80%	
Security Camera Upgrades Phase 2	2021					\$40,000.00			\$10,000.00	\$ 50,000.00	80%	
South Corporate Development - Environmental Analysis	2021				6.1	\$200,000.00		\$50,000.00		\$ 250,000.00	80%	
South Corporate Development - Permitting and Mitigation	2021				6.1	\$120,000.00		\$30,000.00		\$ 150,000.00	80%	
South Corporate Pavement Analysis	2021				6.1	\$48,000.00		\$12,000.00		\$ 60,000.00	80%	
Terminal Window Replacement Phase 2	2021				6.5	\$40,000.00		\$60,000.00	\$0.00	\$ 100,000.00	40%	
Zero Turn Mower	2021					\$8,800.00			\$2,200.00	\$ 11,000.00	80%	
Design Taxiway A Lighting, Shoulders & Realignment Txys B & C	2021	3-51-0035-052-2019				302,400.00				\$ 336,000.00	10%	
Bond Debt South Corporate	2022					\$155,000.00				\$ 155,000.00	100%	
Bond Debt South Corporate	2023					\$155,000.00				\$ 155,000.00	100%	
AHU #1 Dampers 4 Each	2021					\$8,000.00			\$12,000.00	\$ 20,000.00	40%	
AHU #2 Dampers 4 Each	2021					\$8,000.00			\$12,000.00	\$ 20,000.00	40%	
ARFF Tires Rescue 3	2021					\$12,000.00			\$3,000.00	\$ 15,000.00	80%	
Backhoe	2021					\$100,000.00			\$25,000.00	\$ 125,000.00	80%	
Dump Truck with plow	2021					\$120,000.00			\$30,000.00	\$ 150,000.00	80%	
JLG or similar Lift	2021					\$28,000.00			\$7,000.00	\$ 35,000.00	80%	
Main Terminal Building Rehabilitation Design	2021				6.5	\$240,000.00		\$60,000.00		\$ 300,000.00	80%	
Main Terminal Roof Repair Phase 2 Brick Infiltration Mitigation	2021					\$200,000.00		\$0.00	\$300,000.00	\$ 500,000.00	40%	
MDP Over/Under voltage protection main power to terminal	2021					\$12,000.00			\$8,000.00	\$ 20,000.00	60%	
Old Terminal Design & Environmental Phase 1	2022					\$160,000.00			\$40,000.00	\$ 200,000.00	80%	
PA System Replacement	2021					\$44,414.00			\$66,620.00	\$ 111,034.00	40%	
panel on main level	2021					\$12,000.00			\$18,000.00	\$ 30,000.00	40%	
Security Cameras Phase 3	2021					\$40,000.00			\$10,000.00	\$ 50,000.00	80%	
SRE Facility	2022					\$2,400,000.00			\$600,000.00	\$ 3,000,000.00	80%	
SRE Facility Design Siting & Environmental	2022					\$400,000.00			\$100,000.00	\$ 500,000.00	80%	
Sweeper	2021					\$80,000.00			\$20,000.00	\$ 100,000.00	80%	
Wayfinding Study Phase 1	2021					\$20,000.00			\$30,000.00	\$ 50,000.00	40%	
Portable Trash/Water Pump 6"	2021					\$16,000.00			\$4,000.00	\$ 20,000.00	80%	
Bond Debt South Corporate	2024					\$155,000.00				\$ 155,000.00	100%	

Subtotal Funding Commitments for Ongoing Projects \$7,826,015.00 (State Entitlement Funds)

Anticipated FY2021 Entitlement Funds (use last year's amount) \$2,000,000.00

Commonwealth Airport Fund Entitlement Utilization Report and Plan

Funds Available

\$2,000,318.90

(Unexpended Funds Available for Commitment - Funding Commitments for Ongoing Projects + Anticipated FY2021 Entitlement Funds))

Part 2 - Entitlement Utilization Plan FY 2021

A. Project Listing

EUP #	Project Description	6-Year Plan Y / N	Estimated Start Date (Fiscal Year)	AIP Project Number	DOAV Project Number	PFC Project Number	Funding Sources with Estimated Costs					Estimated Total Project Cost	Estimated State Funding Percentage	Estimated PFCs to Reimburse Entitlements	
							Federal	State Entitlement	State Discretionary	PFC	Local				
1	Fuel farm upgrade		FY21					\$ 33,300.00				\$ 66,700.00	\$100,000.00	33.30%	
2	Purchase 22ft Winged Cutter	y	FY21					\$ 56,000.00				\$ 14,000.00	\$70,000.00	80%	
3	Flight information display system		FY21					\$ 40,000.00				\$ 10,000.00	\$50,000.00	80%	
4	Access control system		FY21					\$ 40,000.00				\$ 60,000.00	\$100,000.00	40%	
5	Repair expansion joints ARRF station		FY21					\$ 24,000.00				\$ 6,000.00	\$30,000.00	80%	
6	GA Ramp Rehab Environmental and Design		FY21			6.2		\$ 160,000.00			\$40,000.00		\$200,000.00	80%	
Total Planned Commitments for Future Projects			\$353,300.00	(State Entitlement Funds)											
Funds Available			\$1,647,018.90												

**Commonwealth Airport Fund
Entitlement Utilization Report and Plan**

B. Project Narratives

EUP #	Narrative
1	Fuel Farm upgarde is needed to meet NFPA and FAA guidleines along with Par 139 safety guidlines for Fuel Farm pumps to have overflow and bonding protection while filling fuel trucks. State entitlement 33.3% is for Fuel Farm only.
2	23 ft boomed winged cutter is needed to reach low lying areas on the airfield where a tractor and pull behind mower can not reach due to ditch sides being too steep
3	Flight information Display System is needed airport wide as current system is no longer able to be updated and recently the airport had main system shutdown, new servers, connection boxes, and new software are needed
4	Access Control system is over 15 years old and recently had system crash badging system failed and current system is unable to be updated due to age. Security door keypads to SIDA area are tied into the entire system and need to be upgraded
5	Repair expansion joints on entrance and exit pad/airside at ARRF station. Pad is over 30 years. During the years some joints are non-existent allowing water to infiltrate and freeze causing separation and lifting .Some joints have expanded to over two inches in some locations
6	Ga ramp is unsat in multiple areas. Approved part of PFC program repair. Design and environmental will be phase 1 and is PFC.6.2

Part 3 - Certification

As the Executive Director on behalf of the sponsor, I certify that the information provided above is accurate and complete to the best of my knowledge.

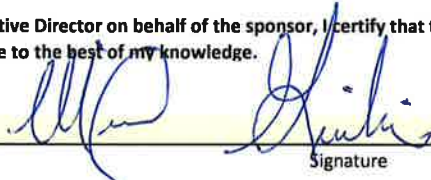

Signature

Michael Giardino, C.M.

Printed Name

5/18/2021

Date

As the Chief Financial Officer on behalf of the sponsor, I certify that the information provided above is accurate and complete to the best of my knowledge.



Signature

Robin Williams

Printed Name

5/18/2021

Date

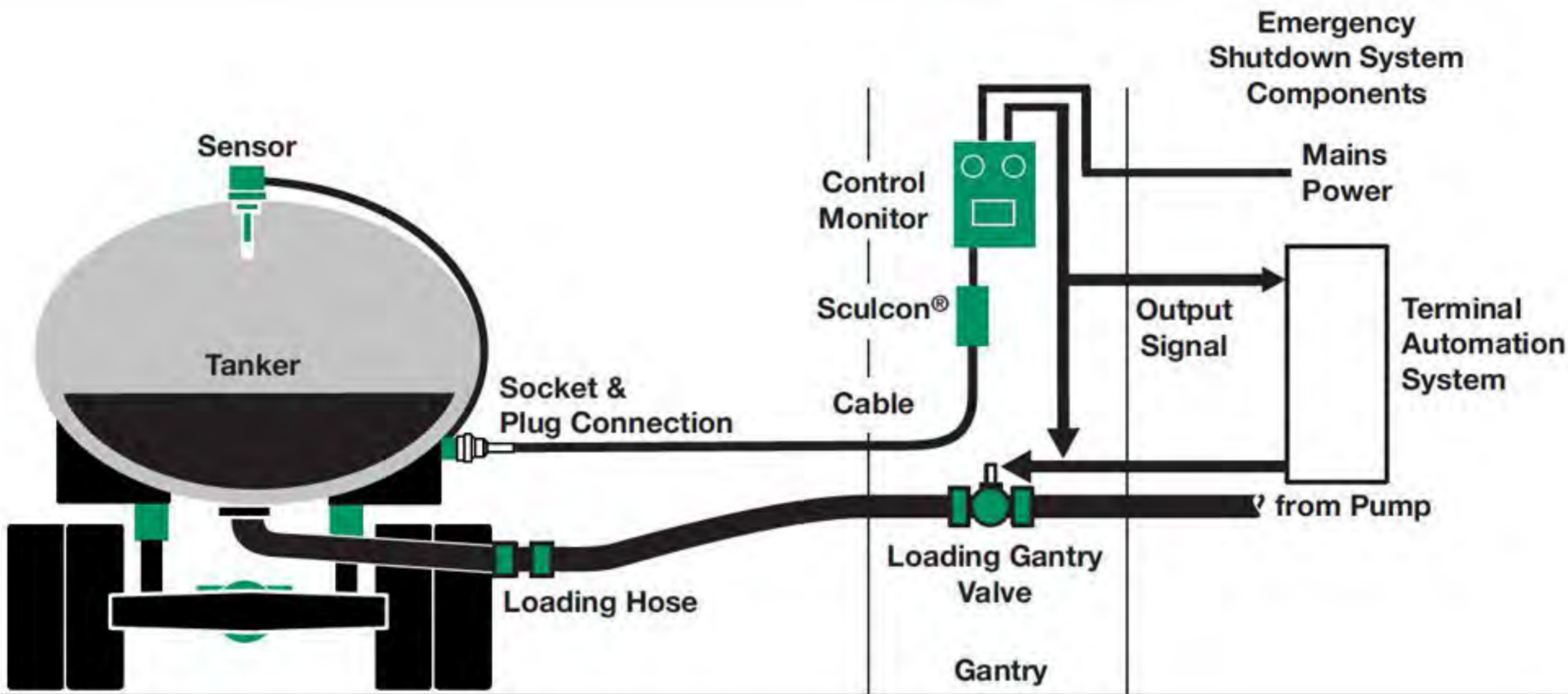



Time	Flight	Destination	Terminal	Gate	Transfer Counter	Remarks
1810	3K 131	Perth	1			
2115	JQ 117	Perth	1			
0500	RX 785	Dhaka	1	D35	C	Ask Airline
1855	FY 3516	Subang	1	D35	C	Re-timed
1900	TR 2952	Shenzhen	2	F51	C,D	Re-timed
1910	TR 2466	Kuala Lumpur	2	F52	E	Gate Closed
1915	MH 616	Kuala Lumpur	2	E24	E	Gate Closed
1915	SQ 424	Mumbai	2	F34	E	Gate Closed
1915	TR 2332	Ho Chi Minh	2	E11	A,B,E,F	Gate Closing
1920	BA 15	Sydney	2	E1	E	Gate Closing
1920	RI 807	Jakarta	1	C20	E	Gate Closing
1925	SQ 918	Manila	2	C20	C,D	Gate Closing
			2	F31	A,B,E,F	Cancelled
			2	F31	A,B,E,F	Gate Closed

Time	Flight	Destination	Terminal	Gate	Transfer Counter	Remarks
2000	MI 468	Kochi	2	F36	E,F	Gate Open
2000	MI 803	Darwin	2	E6	E,F	Gate Open
2000	TR 2656	Dhaka	2	F33	E	Gate Open
2005	NH 6419	Mumbai	3	A19	B	Last Call
2005	MI 478	Hyderabad	2	F58	E,F	Gate Open
2005	NH 6280	Bangalore	2	E4	A,B,E,F	Gate Open
2005	VF 205	Jakarta	1	D38	C	Gate Open
2225	PR 512	Manila	1	D40	D	Boarding
2100	CX 636	Hong Kong	1	D36	D	Re-timed
2015	SQ 221	Sydney	1	D36	D	Re-timed
2015	SQ 852	Guangzhou	3	A4	A,B	Gate Open
2015	SQ 852	Guangzhou	3	B9	A,B	Gate Open
2020	AB 4067	Abu Dhabi	2	E5	E	Gate Open

Time	Flight	Destination	Terminal	Gate	Transfer Counter	Remarks
040	FD 350	Bangkok-DMK	1	C24		
045	AK 718	Kuala Lumpur	1	C20		
045	SQ 452	Male	2	E28	A,B,E,F	
050	TG 410	Bangkok-BKK	1	D34	C,D	
050	TR 2638	Chennai	1	F30	E	
050	TR 2638	Chennai	1	C11		
055	QZ 269	Jakarta	1	D47	C	
100	JQ 8	Melbourne	3	B4	A,B	
100	SQ 227	Melbourne	2	E7	A,B,E,F	
100	VA 5534	Kolkata	1	C13	C	
105	MU 8443	Melbourne	1	D46		
105	QZ 509	Bali	3	A11	A,B	
110	LH 9766	Auckland	1	D46		

Time	Flight	Destination	Terminal	Gate	Transfer Counter	Remarks
145	TR 2982	Guangzhou	2	E3	E	
150	JL 36	Tokyo-HND	1	D41	C,D	
155	SQ 968	Jakarta	2	F30	A,B,E,F	
155	TR 2666	Tiruchirapali	2	F30	E	
200	QZ 271	Jakarta	1	C18		
205	GA 839	Jakarta	3	A12	A,B	
210	FD 352	Bangkok-DMK	1	D46		
210	TR 2652	Bangalore	2	E5	E	
215	NH 844	Tokyo-HND	1	E30	E,F	
215	RI 801	Jakarta	2	F35		
225	AF 257	Paris	1	D48	D	
225	TZ 6	Gold Coast	2	E12		

Time	Flight	Destination	Terminal	Gate	Transfer Counter	Remarks
1930	GA 855	Surabaya	3	A16	A,B	Last Call
1930	TR 2114	Bangkok-BKK	2	F56	E	Gate Closing
1935	3K 687	Kuala Lumpur	1	C17	C	Gate Closing
1935	NH 6417	New Delhi	3	B6	B	Gate Closing
1940	3K 677	Penang	1	C16	C	Gate Closing
2010	JT 151	Jakarta	3	A14	A,B	Gate Open
1945	ET 1321	Christchurch	3	A12	A,B	Last Call
1950	3K 551	Ho Chi Minh	1	C22	C	Gate Closing
1950	TR 2426	Penang	2	F32	E	Last Call
1955	BA 7406	Brisbane	1	C15	C	Last Call
1955	SQ 868	Hong Kong	3	B1	A,B	Last Call
2000	VA 5854	Kuala Lumpur	2	E24	E,F	Boarding

20 Jun 2014 19:20 Gate close 10 mins before departure No boarding calls will be made

Time	Flight	Destination	Terminal	Gate	Transfer Counter	Remarks
2020	GA 837	Jakarta	3	A9	A,B	Gate Open
2020	EK 5062	Sydney	1	C18	C	Gate Open
2025	9W 21	Chennai	3	B3	B	
2025	MI 448	Vishakhapatnam	2	E7	E,F	
2025	MI 5852	Chennai	2	E26	A,B,E,F	Gate Open
2025	TR 2476	Langkawi	2	F40	E	
2025	VN 658	Ho Chi Minh	3	B8	B	
2030	3K 537	Phuket	1	C1	C	
2030	TR 2468	Kuala Lumpur	2	E2	E	
2035	MI 458	Coimbatore	2	F54	E,F	
2035	BA 4192	Koh Samui	1	D40	D	
2035	SQ 446	Dhaka	2	F41	A,B,E,F	

20 Jun 2014 19:20 Gate close 10 mins before departure No boarding calls will be made

Time	Flight	Destination	Terminal	Gate	Transfer Counter	Remarks
115	MI 5710	Kuala Lumpur	2	F31	E	
115	VA 5663	Brisbane	3	A18	A,B	
120	AK 720	Kuala Lumpur	1	C17		
120	BI 424	Brunei	2	F59	E	
120	JT 159	Jakarta	3	A16	A,B	
120	QR 939	Doha	3	A20	A	
120	TR 2664	Tiruchirapali	2	E24	E	
125	EK 355	Dubai	1	C23	C,D	
125	RI 803	Jakarta	2	F32		
130	CX 711	Colombo	1	D42	D	
140	FY 3522	Subang	2	F51		
145	CI 751	Surabaya	1	D32	D	

20 Jun 2014 19:20 Gate close 10 mins before departure No boarding calls will be made

Time	Flight	Destination	Terminal	Gate	Transfer Counter	Remarks
230	AK 756	Penang	1	C25		
230	SQ 636	Tokyo-HND	2	B1	A,B	
235	KE 644	Seoul	1	E32	E,F	
240	EK 404	Melbourne	1	C22	C,D	
000	OZ 752	Seoul	3	B6	A	Re-timed
240	TR 2624	Hyderabad	2	F31	E	
245	MI 466	Kochi	2	E1	E	Cancelled
250	TR 2648	Kochi	2	E1	E	
255	BA 12	London	1	C1	C,D	
255	SQ 468	Colombo	2	E38	A,B,E,F	
300	AK 722	Kuala Lumpur	1	C23		
300	AK 9526	Kuala Lumpur	1	B35		

20 Jun 2014 19:20 Gate close 10 mins before departure No boarding calls will be made

PROJECT #5

900 Bland Blvd, Newport News, VA 23602: NNWB Airport Replace Expansion Joints Site Plan

Legend
National Car Rental

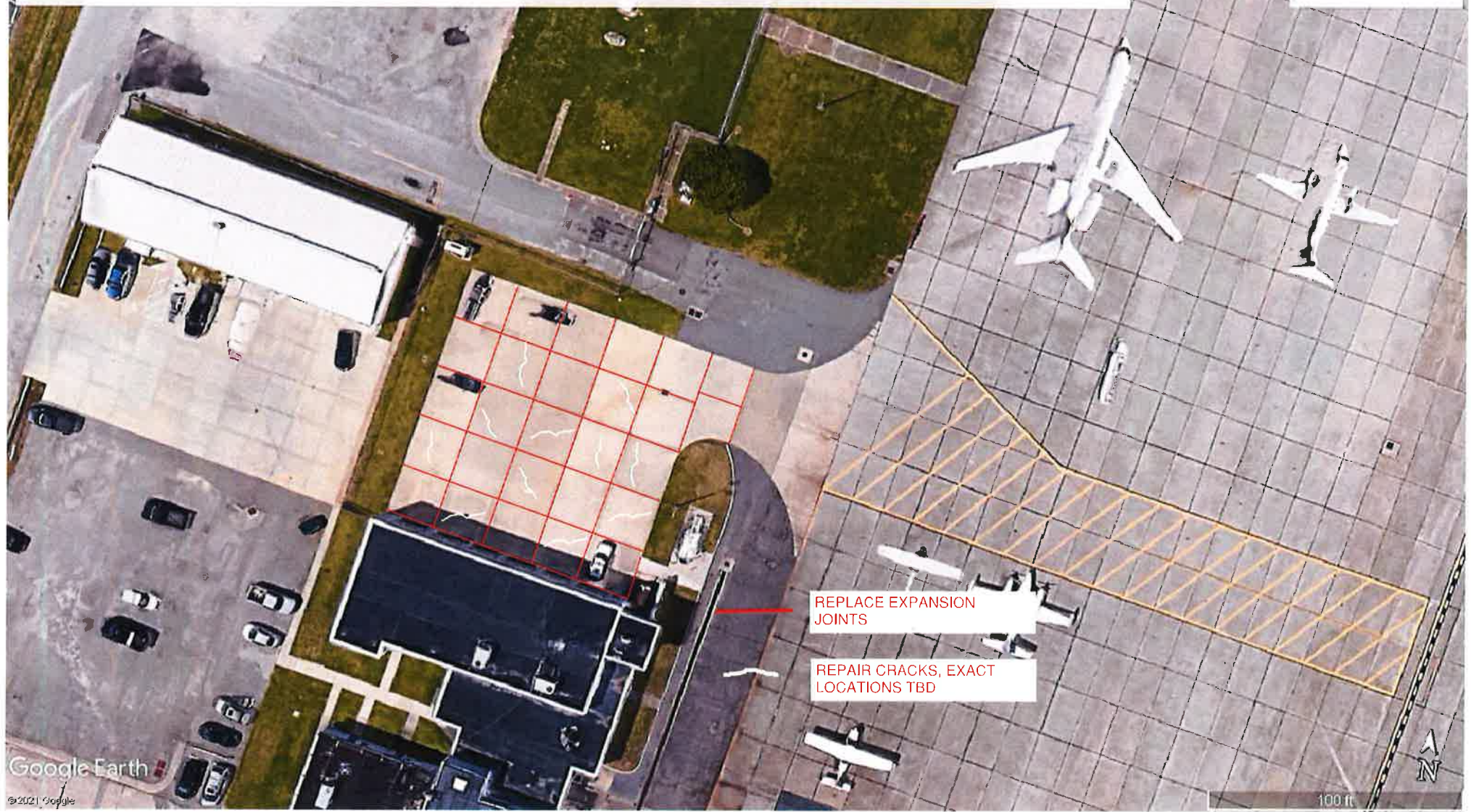

**Commonwealth Airport Fund
Entitlement Utilization Report and Plan**

Sponsor: Shenandoah Valley Regional Airport Commission

Airport: Shenandoah Valley Regional Airport

Part 1 - Entitlement Utilization Report: FY2020

A. Entitlement Funds Available for Expenditure and Commitment

Total Funds Available for Commitment from FY2019	\$1,065,524.39
Entitlement Funds Received in FY2020	\$248,851.07
Interest Earned in FY2020	\$4,926.62
 Subtotal Entitlement Resources Available FY2020	 \$1,319,302.08

B. Reimbursement of State Entitlement Funds - PFC's; Bridge Loans; Other: FY2020

Project Description	AIP Project Number	DOAV Project Number	PFC Project Number	Funding Sources with Final Costs					Total Project Cost	State Funding Percentage	Reimbursement
				Federal	State Entitlement	State Discretionary	PFC	Local			
Rehab Parking Lot-Construction	3-51-0049-035	CF0049-35		1,864,793.00	\$123,778.11	41,773.35		\$41,245.00	\$ 2,071,589.46	8%	\$28,223.90
									\$ -		
									\$ -		
									\$ -		

Subtotal Reimbursement of State Entitlement Funds \$28,223.90

Total Funds Available \$1,347,525.98 (Entitlement Resources Available FY2020 + Reimbursement State Entitlement Funds)

C. Funding Expenditures for Projects Closed: FY2020

Project Description	AIP Project Number	DOAV Project Number	PFC Project Number	Funding Sources with Final Costs					Total Project Cost	State Funding Percentage	Estimated PFCs to Reimburse Entitlements
				Federal	State Entitlement	State Discretionary	PFC	Local			
Taxiway/Runway Rehab	3-51-0049-040			\$1,695,193.69	\$188,354.86				\$ 1,883,548.55	10%	
Airfield Sign Replacement	3-51-0049-041			\$248,299.87	\$27,588.88				\$ 275,888.75	10%	
Environmental Assessment	3-51-0049-042			\$220,570.87	\$24,507.88				\$ 245,078.75	10%	
Construct Taxilanes & Apron for Hangars-Design/Bidding	3-51-0049-043			\$226,254.17	\$25,139.36				\$ 251,393.53	10%	
GA HVAC Renovation	N/A				\$248,839.23			\$67,347.84	\$ 316,187.07	78.7%	
Broom Bristles	N/A				\$4,040.00			\$1,010.00	\$ 5,050.00	80%	
Mobile Device Charging Stations	N/A				\$10,795.51			\$2,698.87	\$ 13,494.38	80%	
FOD sweeper	N/A				\$5,200.00			\$1,300.00	\$ 6,500.00	80%	
Vehicle Lift	N/A				\$6,919.14			\$1,729.78	\$ 8,648.92	80%	
Concrete Pad AC Terminal Ramp	N/A				\$15,927.20			\$3,981.80	\$ 19,909.00	80%	
GA term. Roof ent structure epphus stucco paint/repair	N/A				\$7,376.00			\$1,844.00	\$ 9,220.00	80%	
Runway & Taxiway Bulbs	N/A				\$940.68			\$235.17	\$ 1,175.85	80%	
AWOS Inspection & Repair	N/A				\$2,800.00			\$700.00	\$ 3,500.00	80%	

**Commonwealth Airport Fund
Entitlement Utilization Report and Plan**

Vegetation Management	N/A				\$3,720.00			\$930.00	\$ 4,650.00	80%	
Fence & Vehicle Access Gate	N/A				\$67,160.00			\$16,790.00	\$ 83,950.00	80%	
Antenna & Cabling Upgrade for UHF Radion Communications	N/A				\$3,372.36			\$843.08	\$ 4,215.44	80%	
Install Secure Area Partition-Design	N/A				\$32,997.68			\$8,249.41	\$ 41,247.09	80%	\$33,008.00
SRE facility surge protector	N/A				\$740.00			\$185.00	\$ 925.00	80%	
A/C terminal boiler repairs	N/A				\$3,249.11			\$2,605.14	\$ 5,854.25	55.5%	
AWOS Inspection & Repair-VHF radio	N/A				\$2,503.64			\$625.90	\$ 3,129.54	80%	
Zero turn mower belts & blades	N/A				\$388.64			\$97.60	\$ 486.24	80%	
PTO Shaft John Deere Bushhog	N/A				\$1,177.44			\$294.36	\$ 1,471.80	80%	
GA Gate repairs and sensors	N/A				\$3,501.12			\$875.28	\$ 4,376.40	80%	
PSO/ARFF roof repair	N/A				\$836.26			\$209.07	\$ 1,045.33	80%	
Restripe parking lot	N/A				\$3,429.69			\$1,065.31	\$ 4,495.00	76.3%	
Entrance Sign	N/A				\$20,390.25			\$20,390.25	\$ 40,780.50	50%	

Subtotal Expenditures for Projects Completed: FY2020 \$711,894.93 (State Entitlement Funds)

Unexpended Funds Available for Commitment \$635,631.05 (Total Funds Available - Expenditures for Completed Projects)

**Commonwealth Airport Fund
Entitlement Utilization Report and Plan**

D. Funding Commitments for Ongoing Projects

Project Description	Estimated Fiscal Year of Completion	AIP Project Number	DOAV Project Number	PFC Project Number	Funding Sources with Estimated Costs					Estimated Total Project Cost	Estimated State Funding Percentage	Estimated PFCs to Reimburse Entitlements
					Federal	State Entitlement	State Discretionary	PFC	Local			
Remove and Replace Fuel Farm Tanks	2022	N/A				\$192,040.00			\$582,960.00	\$ 775,000.00	33.3%	
Construct Hangars E & F -Site Design/Bidding	2021	N/A				\$149,281.60			\$37,320.40	\$ 186,602.00	80%	
Install Secure Area Partition-Construction	2021	N/A				\$203,520.00			\$50,880.00	\$ 254,400.00	80%	\$203,520.00
Vegetation Management	2021	N/A				\$9,548.80			\$2,387.20	\$ 11,936.00	80%	
GA Terminal Metal Roof Repairs	2021	N/A				\$11,805.00			\$3,195.00	\$ 15,000.00	78.7%	
Environmental Plans	2021	N/A				\$8,480.00			\$2,120.00	\$ 10,600.00	80%	
AWOS Inspection and Repair	2021	N/A				\$2,880.00			\$720.00	\$ 3,600.00	80%	
Building/Facility Repairs	2021	N/A				\$40,000.00			\$10,000.00	\$ 50,000.00	80%	
Equipment Repairs	2021	N/A				\$12,000.00			\$3,000.00	\$ 15,000.00	80%	
Taxiway K and Apron -Construction-Non Federal	2021	N/A				\$68,000.00			\$17,000.00	\$ 85,000.00	80%	
Environmental Service & Wetland Mitigation	2021	N/A				\$32,000.00			\$8,000.00	\$ 40,000.00	80%	
Construct Hangars E & F Site	2021	N/A				\$447,960.00			\$111,991.20	\$ 559,951.20	80%	

Subtotal Funding Commitments for Ongoing Projects \$1,177,515.40 (State Entitlement Funds)

Anticipated FY2021 Entitlement Funds (use last year's amount) \$600,000.00

Funds Available \$58,115.65 (Unexpended Funds Available for Commitment - Funding Commitments for Ongoing Projects + Anticipated FY2021 Entitlement Funds))

Part 2 - Entitlement Utilization Plan: FY2021

A. Project Listing

EUP #	Project Description	6-Year Plan Y / N	Estimated Start Date (Fiscal Year)	AIP Project Number	DOAV Project Number	PFC Project Number	Funding Sources with Estimated Costs					Estimated Total Project Cost	Estimated State Funding Percentage	Estimated PFCs to Reimburse Entitlements
							Federal	State Entitlement	State Discretionary	PFC	Local			
9	Replace Boiler in AC Terminal		2022	N/A			\$24,975.00			\$20,025.00	\$ 45,000.00	55.5%		
10	Remark Runway		2022				\$16,000.00			\$4,000.00	\$ 20,000.00	80%		
										\$ -	\$ -	80%		
										\$ -	\$ -	80%		
										\$ -	\$ -	80%		
										\$ -	\$ -	80%		

Total Planned Commitments for Future Projects \$40,975.00 (State Entitlement Funds)

Funds Available \$17,140.65

B. Project Narratives

EUP #	Narrative

**Commonwealth Airport Fund
Entitlement Utilization Report and Plan**

9	Replacement of the boiler in the air carrier terminal. Boiler parts for existing are obsolete/unavailable, necessitating replacement of the unit.
10	This project will remark portions of runway 5/23 including runway centerline, taxiway lead in lines and hold markings that have faded and lost reflectivity.

Part 3 - Certification

As the Executive Director on behalf of the sponsor, I certify that the information provided above is accurate and complete to the best of my knowledge.

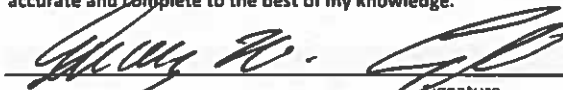
Signature

Gregory W Campbell
Printed Name

6/2/2021
Date

As the Chief Financial Officer on behalf of the sponsor, I certify that the information provided above is accurate and complete to the best of my knowledge.

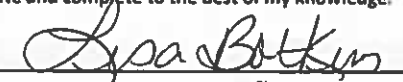
Signature

Lisa Botkin
Printed Name

6/2/2021
Date



© 2021 Google

Google Earth

1985 38°16'05.24" N 78°53'53.50" W elev 1184 ft eye alt 6976 ft

This page intentionally left blank.

GENERAL AVIATION AIRPORTS - DISCRETIONARY FUNDS
RECOMMENDED PROJECTS
STATEWIDE

FUNDED

PRIORITY NO.	AIRPORT NAME	DESCRIPTION	FEDERAL AMOUNT	STATE DISCR. AMOUNT	LOCAL AMOUNT	TOTAL PROJECT AMOUNT
197	Manassas Regional Airport	T-Hangar Taxiway Rehabilitation (Construction)	\$0.00	\$76,763.00	\$19,191.00	\$95,954.00
194	Chesapeake Regional Airport	Terminal Building Restrooms Renovation	\$0.00	\$5,543.00	\$1,386.34	\$6,929.34
194	Manassas Regional Airport	Terminal Building Boiler Replacement	\$0.00	\$38,642.00	\$16,958.00	\$55,600.00
184	Hampton Roads Executive Airport	T-Hangar Taxilane Repair (Construction)	\$0.00	\$5,400.00	\$1,350.00	\$6,750.00
183	Hanover County Municipal Airport	Terminal Building Furniture	\$0.00	\$41,126.00	\$10,282.00	\$51,408.00
176	Virginia Tech - Montgomery Executive Airport	Localizer Access Road (Construction)	\$0.00	\$31,146.00	\$0.00	\$31,146.00
175	Leesburg Executive Airport	Hangar Site Preparation (Construction) (non-AIP)	\$0.00	\$204,800.00	\$51,200.00	\$256,000.00
165	Lee County Airport	Crack Seal, Seal Coat, and Pavement Marking	\$339,000.00	\$30,133.00	\$7,584.00	\$376,717.00
162	Middle Peninsula Regional Airport	Rotating Beacon Replacement (Construction)	\$0.00	\$12,160.00	\$3,040.00	\$15,200.00
158	Mountain Empire Airport	Obstruction Lighting Replacement (Construction)	\$0.00	\$3,568.00	\$892.00	\$4,460.00
157	Luray Caverns Airport	Rotating Beacon Replacement	\$0.00	\$7,316.00	\$1,829.00	\$9,145.00
142	Franklin Municipal Airport	Apron Sinkhole Repair (Construction)	\$0.00	\$11,600.00	\$2,900.00	\$14,500.00
141	Twin County Airport	Terminal Building Security Cameras Replacement	\$0.00	\$3,577.00	\$398.00	\$3,975.00
129	Mountain Empire Airport	Obstruction Removal - ROFA Grading (Design)	\$247,500.00	\$22,000.00	\$5,500.00	\$275,000.00
122	Virginia Highlands Airport	Sinkhole & Drainage Repair (Design)	\$0.00	\$59,200.00	\$14,800.80	\$74,000.80
120	Virginia Tech - Montgomery Executive Airport	Box Hangar Site Preparation (Design)	\$0.00	\$42,445.00	\$10,612.00	\$53,057.00
112	Wakefield Municipal Airport	Runway Lighting Rehabilitation (Design)	\$0.00	\$40,000.00	\$10,000.00	\$50,000.00
105	Virginia Tech - Montgomery Executive Airport	Stormwater Pollution Prevention Plan Update	\$0.00	\$6,530.00	\$1,633.20	\$8,163.20
100	Danville Regional Airport	Box Hangar Site Preparation (Design)	\$0.00	\$71,116.00	\$17,779.00	\$88,895.00
86	Allen C. Perkinson Municipal Airport	Apron Rehabilitation (Design)	\$0.00	\$40,000.00	\$10,000.00	\$50,000.00
40	Grundy Municipal Airport	NPIAS Justification Study	\$0.00	\$129,213.00	\$32,303.00	\$161,516.00
FUNDING TOTALS:			\$586,500.00	\$882,278.00	\$219,638.34	\$1,688,416.34

AVAILABLE DOLLARS FOR THE VAB TO COMMIT: \$2,572,732.95

COMMITTED: \$882,278.00
BALANCE: \$1,690,454.95

GENERAL AVIATION AIRPORTS - DISCRETIONARY FUNDS
NOT RECOMMENDED PROJECTS
STATEWIDE

Not Recommended

PRIORITY NO.	AIRPORT NAME	DESCRIPTION	FEDERAL AMOUNT	STATE DISCR. AMOUNT	LOCAL AMOUNT	TOTAL PROJECT AMOUNT
165	Hampton Roads Executive Airport	Entrance Sign Replacement (Construction)	\$0.00	\$0.00	\$6,988.10	\$6,988.10
164	Culpeper Regional Airport	Greenhouse Road Extension - Phase 1 (Construction)	\$0.00	\$0.00	\$1,936,652.00	\$1,936,652.00
154	New River Valley Airport	Taxiway Crack Seal	\$0.00	\$0.00	\$37,000.00	\$37,000.00
125	Richmond Executive - Chesterfield County Airport	Southeast Apron Expansion (Design)	\$0.00	\$0.00	\$210,600.00	\$210,600.00
125	Richmond Executive - Chesterfield County Airport	Southeast Box Hangars Site Preparation (Design)	\$0.00	\$0.00	\$195,800.00	\$195,800.00
118	Virginia Tech - Montgomery Executive Airport	Terminal Parking Lot Expansion (Design)	\$0.00	\$0.00	\$53,556.00	\$53,556.00
110	Middle Peninsula Regional Airport	Access Road & Box Hangar Site (Environmental)	\$0.00	\$0.00	\$24,000.00	\$24,000.00
70	Hummel Field	Environmental Impact Report	\$0.00	\$0.00	\$39,900.00	\$39,900.00
FUNDING TOTALS:			\$0.00	\$0.00	\$2,504,496.10	\$2,504,496.10

COMMONWEALTH AVIATION FUND ALLOCATION STATUS

For the FYE June 30, 2021

as of July 22, 2020

updated 6/2/21 MS

AIRPORT TENTATIVE ALLOCATION STATUS

AIRPORT	DESCRIPTION	DATE	FAA FY	PROJECT #	DISCRETIONARY	GRANT	T.A. BALANCE
ACCOMACK COUNTY (GA-R)	FUEL TRUCK CONTAINMENT AREA-ENVIRONMENTAL COORDINATION (C)	MAR 18, 21		CS0033-31	12,800.00		
	GRANT-FUEL TRUCK CONTAINMENT AREA-ENVIRONMENTAL COORD (C)	APR 27, 21		CS0033-31		12,800.00	
	RUNWAY 21 TURNAROUND (DES)	MAR 18, 21			6,000.00		
	WETLAND CREDITS REALLOCATION	MAR 18, 21			0.00		6,000.00
ALLEN C. PERKINSON / BLACKSTONE AAF (GA-C) (NON-NPIAS)							
BLUE RIDGE (GA-R)	ADMIN INCREASE-RUNWAY 12-30 REHABILITATION (CON)	FEB 1, 21		CF0032-22	22,751.00		
	AMENDMENT 1-RUNWAY 12-30 REHABILITATION (CON)	FEB 1, 21		CF0032-22		22,751.00	
	LAND ACQUISITION SERVICES RUNWAY 13 END (BRIDGE LOAN)	MAR 18, 21		CS0032-22	33,947.00		
	ADMIN INCR-LAND ACQUIS SERVICES RUNWAY 13 END (BRIDGE LOAN)	APR 12, 21		CS0032-22	103.22		
	GRANT-LAND ACQUISITION SERVICES RUNWAY 13 END (BRIDGE LOAN)	APR 12, 21		CS0032-22		34,050.22	0.00
BRIDGEWATER AIR PARK (GA-L) (NON-NPIAS)	RUNWAY/TAXIWAYS CRACKSEAL, SEALCOAT, AND REMARKING (DES)	MAR 18, 21		CS9072-10	16,800.00		
	GRANT-RUNWAY/TAXIWAYS CRACKSEAL, SEALCOAT, AND REMARK (DE)	APR 27, 21		CS9072-10		16,800.00	0.00
BROOKNEAL/CAMPBELL COUNTY (GA-C)							
CHARLOTTESVILLE-ALBEMARLE (AC-N)							
CHASE CITY (GA-L) (NON-NPIAS)							
CHESAPEAKE REGIONAL (REL)	EASEMENT ACQUISITION-EAST SIDE OBSTR REMOVAL	AUG 17, 18		XXXXXXXX	7,600.00		
	SPONSOR RETURN-EASEMENT ACQUISITION-EAST SIDE OBSTR REMOV.	AUG 3, 20		XXXXXXXX	(7,600.00)		
	T-HANGAR TAXILANES REHAB - PH 1 (CON)	SEP 17, 20		CS0006-55	584,000.00		
	GRANT-T-HANGAR TAXILANES REHAB - PH 1 (CON)	OCT 28, 20		CS0006-55		584,000.00	
	MAINTENANCE EQUIPMENT STORAGE BUILDING (DES)	SEP 17, 20		CS0006-54	46,680.00		
	GRANT-MAINTENANCE EQUIPMENT STORAGE BUILDING (DES)	OCT 28, 20		CS0006-54		46,680.00	
	T-HANGAR TAXILANES REHAB - PH 2 (DES)	SEP 17, 20		CS0006-56	96,800.00		
	GRANT-T-HANGAR TAXILANES REHAB - PH 2 (DES)	OCT 28, 20		CS0006-56		96,800.00	0.00
CREWE MUNICIPAL (GA-L) (NON-NPIAS)	TERMINAL BUILDING ROOF REPAIRS	MAR 18, 21		CS9065-11	5,980.00		
	GRANT-TERMINAL BUILDING ROOF REPAIRS	MAR 29, 21		CS9065-11		5,980.00	0.00
CULPEPER REGIONAL (GA-R)	NORTH T-HGR TAXILANES REHAB (NON-AIP) (CON)-ADD SCOPE	SEP 17, 20			0.00		
	SWPPP AND SPCC PLAN UPDATES	MAR 18, 21		CS0010-29	15,936.38		
	GRANT-SWPPP AND SPCC PLAN UPDATES	APR 12, 21		CS0010-29		15,936.38	0.00

COMMONWEALTH AVIATION FUND ALLOCATION STATUS

For the FYE June 30, 2021

as of July 22, 2020

updated 6/2/21 MS

AIRPORT TENTATIVE ALLOCATION STATUS

AIRPORT	DESCRIPTION	DATE	FAA FY	PROJECT #	DISCRETIONARY	GRANT	T.A. BALANCE
DANVILLE REGIONAL (GA-R)	TAXIWAY 'H' WIDENING & HANGAR SITE PREPARTION (CON)	MAR 18, 21		CS0011-47	1,122,101.00		
	GRANT-TAXIWAY 'H' WIDENING & HANGAR SITE PREPARTION (CON)	APR 27, 21		CS0011-47		1,122,101.00	
	TERMINAL BUILDING REHABILITATION (DES)	MAR 18, 21		CS0011-48	55,922.00		
	GRANT-TERMINAL BUILDING REHABILITATION (DES)	APR 27, 21		CS0011-48		55,922.00	0.00
DINWIDDIE COUNTY (GA-R)	RUNWAY CRACK SEAL	MAR 18, 21		CS0039-35	18,644.00		
	GRANT-RUNWAY CRACK SEAL	MAY 24, 21		CS0039-35		18,644.00	0.00
EAGLE'S NEST (GA-L) (NON-NPIAS)							
EMPORIA-GREENSVILLE (GA-R)							
FALWELL (GA-L) (NON-NPIAS)							
FARMVILLE MUNICIPAL (GA-R)	MAINTENANCE EQUIPMENT STORAGE BUILDING-REPLACEMENT (CON)	MAR 18, 21		CS0015-13	88,476.00		
	GRANT-MAINTENANCE EQUIPMENT STORAGE BUILDING-REPLACEMENT	APR 27, 21		CS0015-13		88,476.00	0.00
FRANKLIN MUNICIPAL (GA-C)							
FRONT ROYAL/WARREN COUNTY (GA-C)	TERMINAL BUILDING ROOF REPLACEMENT (DES)	MAR 18, 21		CS0019-22	3,198.00		
	GRANT-TERMINAL BUILDING ROOF REPLACEMENT (DES)	MAY 17, 21		CS0019-22		3,198.00	0.00
GORDONSVILLE MUNICIPAL (GA-L) (NON-NPIAS)	RUNWAY, TAXIWAY, & APRON REHABILITATION (CON)	MAR 18, 21		CS9070-07	1,056,101.00		
	GRANT-RUNWAY, TAXIWAY, & APRON REHABILITATION (CON)	MAY 3, 21		CS9070-07		1,056,101.00	0.00
GRUNDY (GA-L) (PROPOSED)							
HAMPTON ROADS AIRPORT (REL)	WEST APRON HANGAR SITE PREPARATION (CON)	AUG 16, 19		CS0040-54	2,280,168.00		
	RETURN EXCESS-WEST APRON HANGAR SITE PREPARATION (CON)	JAN 19, 21		CS0040-54	(581,768.00)		
	GRANT-WEST APRON HANGAR SITE PREPARATION (CON)	JAN 19, 21		CS0040-54		1,698,400.00	
	VAB INCR-WASH RACK (WETLAND MITIGATION-CREDITS)	SEP 17, 20		CS0040-49	10,000.00		
	AMEND 1-WASH RACK (WETLAND MITIGATION-CREDITS)	OCT 21, 20		CS0040-49		10,000.00	
	WEST APRON HANGAR SITE PREP (REPACKAGE & BIDDING)	SEP 17, 20		CS0040-53	17,180.00		
	GRANT-WEST APRON HANGAR SITE PREP (REPACKAGE & BIDDING)	SEP 28, 20		CS0040-53		17,180.00	
	ADMIN INCR-PERIMETER FENCING & ACCESS CONTROLS-PH 3 (CON)	OCT 20, 20		CS0040-51	20,762.00		
	AMEND 1-PERIMETER FENCING & ACCESS CONTROLS-PH 3 (CON)	NOV 2, 20		CS0040-51		20,762.00	
	WEST APRON TAXIWAYS REHABILITATION (CON)	MAR 18, 21			40,000.00		
	TAXIWAY ASPHALT REPAIR (PATCHING/MILLING/CRACK FILL)	MAR 18, 21		CS0040-55	15,447.00		
	GRANT-TAXIWAY ASPHALT REPAIR (PATCHING/MILLING/CRACK FILL)	APR 1, 21		CS0040-55		15,447.00	40,000.00

COMMONWEALTH AVIATION FUND ALLOCATION STATUS

For the FYE June 30, 2021

as of July 22, 2020

updated 6/2/21 MS

AIRPORT TENTATIVE ALLOCATION STATUS

AIRPORT	DESCRIPTION	DATE	FAA FY	PROJECT #	DISCRETIONARY	GRANT	T.A. BALANCE
HANOVER COUNTY (REL)	EAST SIDE TERMINAL AREA SITE PREP (CON)	SEP 17, 20		CS0023-43	161,140.00		
	GRANT-EAST SIDE TERMINAL AREA SITE PREP (CON)	OCT 5, 20		CS0023-43		161,140.00	
	EAST SIDE TERMINAL BUILDING (CON)	SEP 17, 20		CS0023-42	1,977,101.00		
	RETURN EXCESS-EAST SIDE TERMINAL BUILDING (CON)	OCT 5, 20		CS0023-42	(10,093.00)		
	GRANT-EAST SIDE TERMINAL BUILDING (CON)	OCT 5, 20		CS0023-42		1,967,008.00	
	LAND AQUIS SERVICES-LEADBETTER PARCELS-BL	SEP 17, 20		CS0023-41	31,200.00		
	GRANT-LAND AQUIS SERVICES-LEADBETTER PARCELS-BL	OCT 19, 20		CS0023-41		31,200.00	
	ADMIN INCR-EAST SIDE DEVELOPMENT-PH 1 (CON) (NON-AIP)	SEP 29, 20		CS0023-36	2,345.66		
	AMENDMENT 2-EAST SIDE DEVELOPMENT-PH 1 (CON) (NON-AIP)	OCT 23, 20		CS0023-36		2,345.66	
	RUNWAY 16 REMARKING	MAR 18, 21		CS0023-44	8,400.00		
	GRANT-RUNWAY 16 REMARKING			CS0023-44		8,400.00	
	RUNWAY 16-34 REHABILITATION (DES)	MAR 18, 21			32,000.00		32,000.00
HUMMEL FIELD (GA-L) (NON-NPIAS)	AIRPORT LAYOUT PLAN UPDATE	MAR 18, 21		CS0076-19	35,990.00		
	GRANT-AIRPORT LAYOUT PLAN UPDATE	MAY 14, 21		CS0076-19		35,990.00	
	ADMIN INCR-AIRPORT LAYOUT PLAN UPDATE	MAY 11, 21			3,566.00		3,566.00
INGALLS FIELD (GA-R)	BOX HGR/MAINT EQUIP STORAGE BUILD SITE PREP/HGR DEMO (DES)	NOV 15, 18		XXXXXXXX	7,200.00		
	SPON RET-BOX HGR/MAINT EQUIP STOR BUILD SITE PREP/HGR DEMO (E	JUL 8, 20		XXXXXXXX	(7,200.00)		
	HANGAR DEMO / MAINT EQUIP STORAGE BUILDING (CON)	FEB 20, 20		XXXXXXXX	26,408.00		
	SPON RET-HANGAR DEMO / MAINT EQUIP STORAGE BUILDING (CON)	JUL 8, 20		XXXXXXXX	(26,408.00)		0.00
LAKE ANNA (GA-L) (NON-NPIAS)							
LAKE COUNTRY (GA-C) (NON-NPIAS)	ADMIN INCR-RWY REHAB & RSA IMPROVE-PH 2 (CON)	JUL 24, 20		CS9060-20	14,624.14		
	AMEND 1-RWY REHAB & RSA IMPROVE-PH 2 (CON)	AUG 19, 20		CS9060-20		14,624.14	
	RUNWAY REHABILITATION & RSA GRADING - PH 3 (CON)	MAR 18, 21		CS9060-21	872,000.00		
	GRANT-RUNWAY REHABILITATION & RSA GRADING - PH 3 (CON)	APR 12, 21		CS9060-21		872,000.00	0.00
LAWRENCEVILLE-BRUNSWICK (GA-L) (NON-NPIAS)							
LEE COUNTY (GA-C)							
LEESBURG EXECUTIVE (REL)	TERMINAL ENTRANCE ROAD REHAB (CON)	SEP 17, 20		CS0027-42	33,379.00		
	RETURN EXCESS-TERMINAL ENTRANCE ROAD REHAB (CON)	NOV 12, 20		CS0027-42	(732.00)		
	GRANT-TERMINAL ENTRANCE ROAD REHAB (CON)	NOV 12, 20		CS0027-42		32,647.00	
	MAINTENANCE EQUIPMENT STORAGE BUILDING (CON)	SEP 17, 20		CS0027-41	81,900.00		
	RETURN EXCESS-MAINTENANCE EQUIPMENT STORAGE BUILDING (CON	NOV 12, 20		CS0027-41	(37,808.37)		
	GRANT-MAINTENANCE EQUIPMENT STORAGE BUILDING (CON)	NOV 12, 20		CS0027-41		44,091.63	0.00

COMMONWEALTH AVIATION FUND ALLOCATION STATUS

For the FYE June 30, 2021

as of July 22, 2020

updated 6/2/21 MS

AIRPORT TENTATIVE ALLOCATION STATUS

AIRPORT	DESCRIPTION	DATE	FAA FY	PROJECT #	DISCRETIONARY	GRANT	T.A. BALANCE
LONESOME PINE (GA-R)	RUNWAY 6-24 REHABILITATION (CON)	MAR 18, 21			480,000.00		480,000.00
LOUISA COUNTY (GA-R)							
LUNENBURG COUNTY (GA-L) (NON-NPIAS)							
LURAY CAVERNS (GA-C)	TERMINAL BUILDING (DES)	MAR 18, 21			144,000.00		
	TERMINAL AREA SITE PREPARATION (DES)	MAR 18, 21		CS0067-19	60,000.00		
	RETURN EXCESS-TERMINAL AREA SITE PREPARATION (DES)	MAY 14, 21		CS0067-19	(2,885.00)		
	GRANT-TERMINAL AREA SITE PREPARATION (DES)	MAY 14, 21		CS0067-19		57,115.00	144,000.00
LYNCHBURG REGIONAL (AC-N)							
MANASSAS REGIONAL (REL)	RUNWAY 16R-34L LIGHTING SYSTEM & PAPI'S (CON)	NOV 21, 19		XXXXXXXX	32,000.00		
	SPON RETURN-RUNWAY 16R-34L LIGHTING SYSTEM & PAPI'S (CON)	JUL 14, 20		XXXXXXXX	(32,000.00)		
	RUNWAY 16R-34L REHABILITATION (CON)	NOV 21, 19		XXXXXXXX	240,000.00		
	SPONSOR RETURN-RUNWAY 16R-34L REHABILITATION (CON)	JUL 14, 20		XXXXXXXX	(240,000.00)		
	ACCESS ROADS/PARKING LOT-PAVEMENT MILL/REPLACE/REMARK	MAR 18, 21		CS0030-40	85,186.00		
	GRANT-ACCESS ROADS/PARKING LOT-PAVEMENT MILL/REPLACE/REMAI	APR 19, 21		CS0030-40		85,186.00	
	MASTER PLAN UPDATE	MAR 18, 21			48,000.00		48,000.00
MECKLENBURG/BRUNSWICK REGIONAL (GA-R)							
MIDDLE PENINSULA REGIONAL (GA-R)	PAVEMENT REPAIR (RWY, TWY, FUEL FARM, APRON, PARKING LOT, & H/	MAR 18, 21		CS0057-40	24,035.00		
	GRANT-PAVEMENT REPAIR (RWY, TWY, FUEL FARM, APRON, PARKING LI	MAY 3, 21		CS0057-40		24,035.00	0.00
MOUNTAIN EMPIRE (GA-C)	SECURITY CAMERA REPLACEMENT	SEP 17, 20		CS0031-34	6,282.00		
	GRANT-SECURITY CAMERA REPLACEMENT	NOV 2, 20		CS0031-34		6,282.00	0.00
NEW KENT COUNTY (GA-C)	QTPOD TERMINAL FUEL DESPENSOR M4000 REPLACEMENT	SEP 17, 20		CS0041-16	11,390.00		
	GRANT-QTPOD TERMINAL FUEL DESPENSOR M4000 REPLACEMENT	NOV 2, 20		CS0041-16		11,390.00	0.00
NEW LONDON (GA-L) (NON-NPIAS)							
NEW MARKET (GA-L) (NON-NPIAS)							
NEWPORT NEWS/WILLIAMSBURG INT'L (AC-S)							
NEW RIVER VALLEY (GA-R)	TAXIWAY CRACKSEAL (CON)	MAR 18, 21		XXXXXXXX	2,960.00		

COMMONWEALTH AVIATION FUND ALLOCATION STATUS

For the FYE June 30, 2021

as of July 22, 2020

updated 6/2/21 MS

AIRPORT TENTATIVE ALLOCATION STATUS

AIRPORT	DESCRIPTION	DATE	FAA FY	PROJECT #	DISCRETIONARY	GRANT	T.A. BALANCE
	SPONSOR RETURN-TAXIWAY CRACKSEAL (CON)	JUN 1, 21		XXXXXXXXXX	(2,960.00)		
	PARKING LOT REHABILITATION (DES/CON)	MAR 18, 21		CS0012-09	86,882.00		
	ADMIN INCREASE-PARKING LOT REHABILITATION (DES/CON)	MAY 7, 21		CS0012-09	718.00		
	GRANT-PARKING LOT REHABILITATION (DES/CON)	MAY 7, 21		CS0012-09		87,600.00	
	MASTER PLAN UPDATE	MAR 18, 21			40,000.00		40,000.00
NORFOLK INT'L (AC-S)							
ORANGE COUNTY (GA-C)							
RICHMOND EXEC-CHESTERFIELD CO (REL)	FUELING SYSTEM (DEMO) AND FUELING TRUCK PARKING AREA (CON)	MAR 18, 21		CS0007-46	200,000.00		
	GRANT-FUELING SYSTEM (DEMO) AND FUEL TRUCK PARKING AREA (CO	APR 14, 21		CS0007-46		200,000.00	
	ACCESS ROAD REHABILITATION (DES)	MAR 18, 21		CS0007-45	80,800.00		
	GRANT-ACCESS ROAD REHABILITATION (DES)	APR 14, 21		CS0007-45		80,800.00	0.00
RICHMOND INTERNATIONAL (AC-S)	OBST REM, CLEAR & GRUB (DES/CON) (\$475,732.80)	SEP 17, 20					
	SERVICE ROADS WIDENING (DES/CON) (\$1,565,519.20)	SEP 17, 20					0.00
SHANNON (GA-C)							
SHENANDOAH VALLEY (AC-S)							
SMITH MOUNTAIN LAKE (NON-NPIAS)							
STAFFORD COUNTY (REL)	T-HANGAR SITE PREPARATION (BIDDING & CON)	SEP 17, 20		CS0069-32	261,000.00		
	GRANT-T-HANGAR SITE PREPARATION (BIDDING & CON)	NOV 16, 20		CS0069-32		261,000.00	
	SWPPP UPDATE	SEP 17, 20		CS0069-31	10,880.00		
	RETURN EXCESS-SWPPP UPDATE	NOV 16, 20		CS0069-31	(480.00)		
	GRANT-SWPPP UPDATE	NOV 16, 20		CS0069-31		10,400.00	
	RUNWAY EXTENSION-PHASE 2 (CON)	MAR 18, 21			464,000.00		464,000.00
SUFFOLK (GA-R)							
TANGIER ISLAND (GA-C)							
TAPPAHANNOCK - ESSEX COUNTY (GA-R)	VAB INCR-FUELING SYSTEM CREDIT CARD READER REPLACEMENT	JAN 17, 21		CS0081-21	1,546.71		
	AMENDMENT 5-FUELING SYSTEM CREDIT CARD READER REPLACEMENT	FEB 1, 2021		CS0081-21		1,546.71	0.00
TAZEWELL COUNTY (GA-R)	MAINTENANCE EQUIPMENT STORAGE BUILDING (CON)	SEP 17, 20		CS0053-38	16,000.00		
	GRANT-MAINTENANCE EQUIPMENT STORAGE BUILDING (CON)	OCT 5, 20		CS0053-38		16,000.00	

COMMONWEALTH AVIATION FUND ALLOCATION STATUS

For the FYE June 30, 2021

as of July 22, 2020

updated 6/2/21 MS

AIRPORT TENTATIVE ALLOCATION STATUS

AIRPORT	DESCRIPTION	DATE	FAA FY	PROJECT #	DISCRETIONARY	GRANT	T.A. BALANCE
	T-HANGAR SITE PREPARATION (CON)	MAR 18, 21		CS0053-39	400,000.00		
	GRANT-T-HANGAR SITE PREPARATION (CON)	APR 19, 21		CS0053-39		400,000.00	0.00
TWIN COUNTY (GA-C)	BOX HANGAR SITE PREPARATION (ENVIRON REIMB & DESIGN)	MAR 18, 21		CS0020-28	48,000.00		
	GRANT-BOX HANGAR SITE PREPARATION (ENVIRON REIMB & DESIGN)	MAY 10, 21		CS0020-28		48,000.00	0.00
VIRGINIA HIGHLANDS (GA-R)	RWY 6-24 EXT-LAND ACQ SERV/FEE (JOHNSON/SNEAD/GENT)-MY5-BL	SEP 17, 20		CS0001-32	342,831.04		
	AMEND 7-RWY 6-24 EXT-LAND ACQ SERV/FEE (JOHNSON/SNEAD/GENT)-H	OCT 19, 20		CS0001-32		342,831.04	
	TAXILANE AND ROADWAY REHABILITATION (CON)	SEP 17, 20		CS0001-37	490,196.00		
	GRANT-TAXILANE AND ROADWAY REHABILITATION (CON)	OCT 26, 20		CS0001-37		490,196.00	
	RUNWAY 6-24 EXTENSION-PHASE 5 (EMBANKMENT SEASON 3)	MAR 18, 21			334,000.00		
	ADMIN INCR-RUNWAY 6-24 EXTENSION-PHASE 2 (BOX CULVERT) (CON)	MAR 20, 21		CF0001-34	8,231.81		
	AMEND 1-RUNWAY 6-24 EXTENSION-PHASE 2 (BOX CULVERT) (CON)	JUN 1, 21		CF0001-34		8,231.81	334,000.00
VIRGINIA TECH (GA-R)	RUNWAY 12-30 EXTENSION-LAND ACQUISITION-PHASE 3	MAR 18, 21			57,777.00		
	ADDITIONAL SECURITY CAMERAS	MAR 18, 21		CS0002-21	3,442.00		
	GRANT-ADDITIONAL SECURITY CAMERAS	APR 27, 21		CS0002-21		3,442.00	
	VAB INCR-RUNWAY 12-30 EXTENSION-PH 2 (CON)	MAR 18, 21		CF0002-21	81,517.53		
	GRANT-VAB INCR-RUNWAY 12-30 EXTENSION-PH 2 (CON)	APR 12, 21		CF0002-21		81,517.53	57,777.00
WAKEFIELD MUNICIPAL (GA-C) (NON-NPIAS)							
WARRENTON-FAUQUIER (REL)							
WILLIAM M TUCK (GA-R)							
WILLIAMSBURG-JAMESTOWN (GA-C) (NON-NPIAS)	T-HANGAR #2 SITE PREPARATION (DES)	MAR 18, 21		CS9010-38	36,800.00		
	GRANT-T-HANGAR #2 SITE PREPARATION (DES)	APR 27, 21		CS9010-38		36,800.00	0.00
WINCHESTER REGIONAL (GA-R)	TERMINAL AREA SITE PREPARATION (CON)-PHASE 1	SEP 17, 20		CS0059-30	888,000.00		
	RETURN EXCESS-TERMINAL AREA SITE PREPARATION (CON)-PHASE 1	NOV 9, 20		CS0059-30	(13,019.00)		
	GRANT-TERMINAL AREA SITE PREPARATION (CON)-PHASE 1	NOV 9, 20		CS0059-30		874,981.00	
	TERMINAL AREA SITE PREPARATION (CON)-PHASE 2	MAR 18, 21		CS0059-31	195,200.00		
	RETURN EXCESS-TERMINAL AREA SITE PREPARATION (CON)-PHASE 2	APR 19, 21		CS0059-31	(11,698.00)		
	GRANT-TERMINAL AREA SITE PREPARATION (CON)-PHASE 2	APR 19, 21		CS0059-31		183,502.00	
	TERMINAL BUILDING (DES)	MAR 18, 21		CS0059-32	231,000.00		
	RETURN EXCESS-TERMINAL BUILDING (DES)	APR 19, 21		CS0059-32	(1,184.00)		
	GRANT-TERMINAL BUILDING (DES)	APR 19, 21		CS0059-32		229,816.00	0.00





COMMONWEALTH AVIATION FUND ALLOCATION STATUS

For the FYE June 30, 2021
as of July 22, 2020

updated 6/2/21 MS

AIRPORT TENTATIVE ALLOCATION STATUS

AIRPORT	DESCRIPTION	DATE	FAA FY	PROJECT #	DISCRETIONARY	GRANT	T.A. BALANCE
	OPEN T.A. BALANCE AS OF 8/28/19						1,649,343.00
	TOTAL PLACED UNDER GRANT FY 2020					11,652,147.12	
	TOTAL ALLOCATIONS				13,301,490.12		
	TEST CHECK					0.00	

-  STATE/LOCAL PROJECT
-  FEDERAL/STATE/LOCAL PROJECT
-  COMBINED FUND - STATE/LOCAL PROJECT
-  COMBINED FUND - FEDERAL/STATE/LOCAL PROJECT

Balance	Test	DEPARTMENT OF AVIATION							
330,279.16	0.00	MAINTENANCE PROGRAM							
	No Funds	Allocations and Expenditures							
	Other issues	For the FYE June 30, 2021							
		APPROPRIATION JULY, 2020				1,000,000.00			OBSTRUCTIONS
06/09/21 - ANJ		LESS PRIOR YEAR OVERCOMMITMENT				0.00			
		PLUS: PRIOR YEAR COMMITMENTS				XXXXXX			
		TOTAL APPROPRIATION FY 2020				1,000,000.00			
** \$100,000 MAX TO SPONSOR PER YEAR									
							AIRPORT ALLOCATION STATUS		
AIRPORT	Expiration	DESCRIPTION / VO. PAYEE	VO. NO.	DATE	PROJ. #	ALLOCATION	EXPENDITURE	UNEXP. BALANCE	
ACCOMACK (T 80%, F 67%) 76,981.20	6/1/20	FY20 AWOS INSP & REPAIR CLOSED - SP		7/1/19 5/5/21	MT0033-05 C	965.00 (965.00)			0.00
	11/1/20	PAINTING CONFERENCE ROOM CLOSED - SP Accomack County	6138	2/26/20 10/15/20 10/20/20	MT0033-13 C	1,400.00		1,400.00	0.00
	9/1/21	FY21 AWOS INSP & REPAIR Accomack County	6242	7/1/20 12/7/20	MT0033-17 C	3,500.00	2,280.00		1,220.00
	11/1/20	AWOS TEMP PROBE EVAL INCREASE FOR 95% FUNDING - VC Accomack County	5966	4/14/20 8/7/20 8/10/20	MT0033-18 C	1,004.00 188.25		1,192.25	0.00
	11/1/20	AWOS TEMP PROBE REPLACE FINAL DECREASE - SP Accomack County	6013	8/6/20 9/2/20 9/9/20	MT0033-19 C	1,981.82 (578.41)		1,403.41	0.00
	12/1/20	EVALUATE PCL Accomack County	6243	10/1/20 12/7/20	MT0033-20 C	912.00	912.00		0.00
	3/1/21	EVALUATE PAPI RWY 3 FINAL DECREASE - SP Accomack County	6244	11/4/20 12/3/20 12/7/20	MT0033-21 C	912.00 (640.00)		272.00	0.00
	3/1/21	EVALUATE AWOS TEMP SENSOR FINAL - SP Accomack County	6358	12/8/20 2/3/21 2/9/21	MT0033-22 C	1,083.00		1,083.00	0.00
	3/1/21	PCL Repair FINAL - SP Accomack County	6359	1/8/20 2/3/21 2/9/21	MT0033-23 C	1,231.20		1,231.20	0.00
	9/1/21	REPLACE TERMINAL BUILDING ENTRANCE DOORS		5/27/21	MT0033-24	6,960.00			6,960.00
	9/1/21	AWOS EVAL - TEMP SENSOR		5/27/21	MT0033-25	1,002.25			1,002.25
	9/1/21	REPLACE PCA VOICE SPARE AWOS		5/27/21	MT0033-26	4,062.69			4,062.69
BLACKSTONE (T: ?, F: 33%) 100,000.00		NEXT PROJECT			MT0008-13	0.00			0.00
BLUE RIDGE (T 80%, F 80%) 89,219.93	11/1/20	TAXIWAY REGULATOR REPLACEMENT CLOSED - SP Blue Ridge Airport Authority	5989	2/20/20 8/19/20 8/20/20	MT0032-58 C	7,280.07		7,280.07	0.00
	6/1/21	FY21 AWOS INSP & REPAIR		7/1/20	MT0032-60	3,500.00			3,500.00
	3/1/21	PAPI HARNESS REPLACEMENT final - sp		8/6/20 11/9/20	MT0032-61 C	2,565.95			0.00

AIRPORT	Expiration	DESCRIPTION / VO. PAYEE	VO. NO.	DATE	PROJ. #	AIRPORT ALLOCATION STATUS		
						ALLOCATION	EXPENDITURE	UNEXP. BALANCE
		Blue Ridge Airport Authority	6202	11/12/20	MT0032-61		2,565.95	
	3/1/21	EVAL AWOS OUTAGE		8/19/20	MT0032-62	C	1,083.00	
		Blue Ridge Airport Authority	6203	11/12/20	MT0032-62		1,083.00	0.00
	3/1/21	SECURITY GATE REPAIR		1/8/20	MT0032-63	C	3,960.00	
		FINAL - SP		2/3/21	MT0032-63			0.00
		Blue Ridge Airport Authority	6360	2/9/21	MT0032-63		3,960.00	
BRIDGEWATER Identified 9/15/16 95,307.75	6/1/21	FY21 AWOS INSP & REPAIR		7/1/20	MT9072-17	C	3,500.00	
		Dynamic Aviation group Inc	6589	5/24/21	MT9072-17		2,280.00	1,220.00
	6/1/21	EVAL AWOS OUTAGE		3/18/21	MT9072-18	C	1,192.25	
		Dynamic Aviation group Inc	6590	5/24/21	MT9072-18		1,192.25	0.00
BROOKNEAL (T: ?, F: 67%) 97,116.00	6/15/19	WEED CONTROL 2019		1/17/19	MT0062-29	C	2,884.00	
		FINAL		6/11/19	MT0062-29			0.00
		Brookneal Campbell Airport Authority	4408	6/13/19	MT0062-29		2,884.00	
	9/1/21	FY21 AWOS INSP & REPAIR		7/1/20	MT0062-34		3,500.00	
								3,500.00
CHARLOTTESVILLE 93,616.00		NEXT			MT0004-56		0.00	0.00
CHASE CITY 95,360.00	11/1/20	FY20 AWOS INSP & REPAIR		7/1/19	MT0005-18	C	1,140.00	
		FINAL - INCREASE (ALLOWABLE 10%)		6/22/20	MT0005-18			0.00
		Town of Chase City	5877	7/1/20	MT0005-18		1,140.00	
	9/1/21	FY21 AWOS INSP & REPAIR		7/1/20	MT0005-19		3,500.00	
		Town Of Chase City	6163	10/26/20	MT0005-19		1,140.00	1,220.00
		Town Of Chase City	6584	5/18/21	MT0005-19		1,140.00	
		NEXT PROJECT			MT0005-20		0.00	0.00
CHESAPEAKE(T: 80, F: 50%) 85,845.27	9/1/21	FY21 AWOS INSP & REPAIR		7/1/20	MT0006-77		3,500.00	
		FINAL - INCREASE (ALLOWABLE 10%)		6/9/21	MT0006-77		24.50	3,524.50
	3/1/21	KUBOTA TRACTOR W/ LAND PRIDE BANK MOWER		8/10/20	MT0006-78	C	10,630.23	
		FINAL		11/6/20	MT0006-78			0.00
		Chesapeake Airport Authority	6199	11/12/20	MT0006-78		10,630.23	
	3/31/21	RWY 23 REIL REPAIR		10/20/20	MT0006-79	C	1,704.13	
		FINAL		3/3/21	MT0006-79			0.00
		Chesapeake Airport Authority	6419	3/8/21	MT0006-79		1,704.13	
	3/31/21	RWY 23 PAPI REPAIR		11/2/20	MT0006-80	C	2,514.04	
		FINAL - DECREASE		3/3/21	MT0006-80		(640.00)	0.00
		Chesapeake Airport Authority	6420	3/8/21	MT0006-80		1,874.04	
	6/1/21	RUNWAY SWEEPER PARTS (50%)		3/18/21	MT0006-81	C	1,076.97	
		FINAL - DECREASE		5/26/21	MT0006-81		(9.40)	0.00
		Chesapeake Airport Authority	6607	6/1/21	MT0006-81		1,067.57	
CHESTERFIELD (T: ?, F: 33%) 94,000.00	11/1/20	DRAINAGE PIPE REPAIR		7/28/20	MT0007-68	C	51,960.00	
		FINAL - DECREASE		10/8/20	MT0007-68		(45,960.00)	0.00
		Chesterfield County	6120	10/14/20	MT0007-68		6,000.00	
CREWE (T: 80, F: 67%) 89,780.00	6/1/21	FY21 AWOS INSP & REPAIR		7/1/20	MT9065-27		3,500.00	
		Town of Crewe	6372	2/16/21	MT9065-27		2,280.00	1,220.00
	11/1/20	AIRFIELD FIXTURES REPAIR		7/14/20	MT9065-28	C	6,720.00	
		FINAL		10/21/20	MT9065-28			0.00
		Town of Crewe	6165	10/26/20	MT9065-28		6,720.00	
		AWOS BACKUP BATTERY REPLACEMENT		5/27/21	MT9065-29		1,085.38	1,085.38

AIRPORT	Expiration	DESCRIPTION / VO. PAYEE	VO. NO.	DATE	PROJ. #	AIRPORT ALLOCATION STATUS			
						ALLOCATION	EXPENDITURE	UNEXP. BALANCE	
CULPEPER (T: ?, F: 67%) 95,360.00	11/1/20	FY20 AWOS INSP & REPAIR		7/1/19	MT0010-41	C	1,060.00		
		INCREASE - ALLOW INCR - VC County of Culpeper VA	5956	8/5/20 8/6/20	MT0010-41 MT0010-41		80.00	1,140.00	0.00
	9/1/21	FY21 AWOS INSP & REPAIR County of Culpeper VA	6608	7/1/20 0/01/21	MT0010-44 MT0010-44		3,500.00	2,280.00	1,220.00
	11/1/20	LIFTMASTER GATE CONTROLLER REPLACEMENT		7/28/20	MT0010-45	C	5,293.64		
		FINAL INCREASE TO 80% - SP County of Culpeper	6166	10/22/20 10/26/20	MT0010-45 MT0010-45		3,176.18	8,469.82	0.00
	9/1/21	2021 WEEDKILL APPLICATION		5/27/21	MT0010-46		3,289.00		3,289.00
DANVILLE (T: 28.1%, PARK 25%) 70,208.48	12/30/20	RAM 4500 DUMP TRUCK		1/7/20	MT0011-43	C	26,613.83		
		FINAL - SP City of Danville	6288	1/6/21 1/11/21	MT0011-43 MT0011-43			26,613.83	0.00
	12/30/20	SNOW PLOW		1/7/20	MT0011-44	C	3,177.69		
	FINAL DECREASE - SP City of Danville	6289	1/6/21 1/11/21	MT0011-44 MT0011-44		(19.49)	3,158.20	0.00	
	11/1/20	LIGHT REPLACEMENT ON RAMP		3/19/20	MT0011-46	C	2,346.38		
		FINAL DECREASE- SP City of Danville	6140	10/19/20 10/20/20	MT0011-46 MT0011-46		(11.97)	2,334.41	0.00
3/1/21	TAXIWAY A REGULATOR REPAIR closed - sp City of Danville	6421	12/8/20 3/2/21 3/8/21	MT0011-47 MT0011-47 MT0011-47	C	2,720.16 (43.35)	2,676.81	0.00	
DEPARTMENT OF MILITARY AFFAIRS	3/1/21	FY20 AWOS INSP & REPAIR		7/1/19	MT0DMA-06	D	3,150.00		
		3/16 VC closed project due to lack of activity		3/16/21	MT0DMA-06		(3,150.00)		0.00
	6/1/21	FY21 AWOS INSP & REPAIR		7/1/20	MT0DMA-07		3,500.00		3,500.00
DINWIDDIE (T: 72%, F: ?%) 95,227.72	11/1/20	FY20 AWOS INSP & REPAIR		7/1/19	MT0039-21	C	2,010.00		
		FINAL INCREASE - SP Dinwiddle Airport and Industrial Authority	6176	11/2/20 11/2/20	MT0039-21 MT0039-21		175.00	2,185.00	0.00
		RWY 5 REILS/ODALS REPAIR Dinwiddle Airport and Industrial Authority	6177	2/6/20 11/2/20	MT0039-26 MT0039-26	C	2,587.28	2,587.28	0.00
	6/1/21	FY21 AWOS INSP & REPAIR		7/1/20	MT0039-29		3,500.00		3,500.00
	11/1/20	EVAL REILS RWY 23		8/6/20	MT0039-30	D	844.00		
		Eligibility denial - project closed 11/2/20 - recorded here 2/9/21 SS					(844.00)		0.00
6/1/21	REPLACE REIL CONTROL BOARD		1/22/21	MT0039-31		1,635.62		1,635.62	
6/1/21	EVAL RWY 5 REILS AND ODALS		1/22/21	MT0039-32		912.00		912.00	
EAGLE'S NEST 97,720.00	6/1/21	FY21 AWOS INSP & REPAIR		7/1/20	MT9089-27	C	3,500.00		
		Aero Drive Farm Inc	6396	3/2/21	MT9089-27			1,140.00	0.00
		FINAL - DECREASE Aero Drive Farm, Inc.	6581	5/12/21 5/18/21	MT9089-27 MT9089-27		(1,220.00)	1,140.00	
	NEXT PROJECT			MT9089-28		0.00		0.00	
EMPORIA-GREENSVILLE (T: 77, F: ?%) 96,500.00	6/1/21	FY21 AWOS INSP & REPAIR		7/1/20	MT0013-79		3,500.00		3,500.00
		OBSTRUCTION IDENTIFICATION		5/27/21	MT0013-80		3,360.00		3,360.00

AIRPORT	Expiration	DESCRIPTION / VO. PAYEE	VO. NO.	DATE	PROJ. #	AIRPORT ALLOCATION STATUS		
						ALLOCATION	EXPENDITURE	UNEXP. BALANCE
		EVALUATION AWOS OUTAGE (95%)		5/27/21	MT0013-81	1,273.00		1,273.00
FALWELL 100,000.00 Missing State Funding Annual Report		NEXT PROJECT			MT9073-17	0.00		0.00
FARMVILLE (T: 80, F: 33%) 95,170.86	11/1/20	FY20 AWOS INSP & REPAIR FINAL - DECREASE Town of Farmville	6107	7/1/19 10/6/20 10/8/20	MT0015-09 C MT0015-09 MT0015-09	2,010.00 (870.00)		0.00
	6/1/21	FY21 AWOS INSP & REPAIR Town of Farmville	6346	7/1/20 2/1/21	MT0015-10 MT0015-10	3,500.00		
			6585	5/18/21	MT0015-10		1,140.00	1,220.00
	11/1/20	PHOTOCELL REPLACEMENT FINAL Town of Farmville	6148	7/14/20 10/20/20 10/21/20	MT0015-11 C MT0015-11 MT0015-11	189.14		0.00
	6/1/21	QT POD REPLACEMENT FINAL Town of Farmville	6447	2/11/21 3/10/21 3/15/21	MT0015-12 C MT0015-12 MT0015-12	9,879.15		0.00
	9/1/21	AWOS TROUBLESHOOT		4/1/21	MT0015-13	1,140.00		1,140.00
FRANKLIN (T: 80, F: 67%) Obst. Mitigated 7/17/19 95,535.00	3/1/21	FY20 AWOS INSP & REPAIR		7/1/19	MT0017-71	965.00		965.00
	6/1/21	FY21 AWOS INSP & REPAIR		7/1/20	MT0017-73	3,500.00		3,500.00
FRONT ROYAL (T: 78%, F: ?%) 96,182.60 UNMITIGATED OBSTRUCTIONS FROM	6/1/20	WINDSOCK LIGHTING REPAIR FINAL County of Warren	5878	3/24/20 6/11/20 7/1/20	MT0019-55 C MT0019-55 MT0019-55	1,048.00		0.00
	11/1/20	AIRPORT MOWING TRACTOR REPAIR (50%) FINAL - DECREASE County of Warren	5967	5/19/20 8/6/20 8/10/20	MT0019-57 C MT0019-57 MT0019-57	408.86 (91.46)		0.00
	6/1/21	FY21 AWOS INSP & REPAIR		7/1/20	MT0019-58	3,500.00		3,500.00
		NEXT PROJECT			MT0019-59	0.00		0.00
GORDONSVILLE 94,043.71	11/1/20	AWOS OUTAGE EVALUATION FINAL Town of Gordonsville	5895	6/12/20 7/2/20 7/13/20	MT9070-29 C MT9070-29 MT9070-29	1,192.25		0.00
	6/1/21	FY21 AWOS INSP & REPAIR Town of Gordonsville	6012	7/1/20 9/9/2020	MT9070-30 C MT9070-30	3,500.00		0.00
			6504	4/19/2021	MT9070-30		1,140.00	
			6557	5/4/2021	MT9070-30	(80.00)		
				5/10/2021	MT9070-30		1,140.00	
	11/1/20	AWOS VHF RADIO REPAIR (95%) FINAL Town of Gordonsville	5992	7/14/20 8/13/20 8/20/20	MT9070-31 C MT9070-31 MT9070-31	1,344.04		0.00
				4/1/21	MT9070-32	884.22		0.00
			6558	5/4/21 5/10/21	MT9070-32 MT9070-32		884.22	
GRUNDY 100,000.00		NEXT PROJECT			MT0022-17	0.00		0.00
HAMPTON ROADS 97,440.00	11/1/20	2020 VEGETATION MANAGEMENT - MOW MARSH CLOSED - SP Hampton Roads Airport	5937	3/25/20 7/29/20 7/30/20	MT0040-73 C MT0040-73 MT0040-73	2,560.00		0.00
							2,560.00	

AIRPORT	Expiration	DESCRIPTION / VO. PAYEE	VO. NO.	DATE	PROJ. #	AIRPORT ALLOCATION STATUS			
						ALLOCATION	EXPENDITURE	UNEXP. BALANCE	
	11/120	100 GAL SPRAYER HONDA 5.5HP Hampton Roads Airport	5896	4/2/20 7/13/20	MT0040-74 MT0040-74	C C	2,178.00	2,178.00	0.00
	6/1/21	2021 WIND CONE REPAIR FINAL DECREASE - SP Hampton Roads Airport	6609	3/18/21 5/25/21 6/1/21	MT0040-75 MT0040-75 MT0040-75	C	3,212.00 (183.70)	3,028.30	0.00
	9/1/21	RWY 28 REILS REPAIR		3/18/21	MT0040-76		5,892.00		5,892.00
	9/1/21	2021 WEEDKILL APPLICATION		5/27/21	MT0040-77		3,480.00		3,480.00
HANOVER (T: ?, F: 50%) 92,960.00	3/1/21	REPLACE FAILED HVAC TERMINAL CONF ROOM CLOSED - SP Hanover County Community	6393	12/8/20 2/17/21 3/2/21	MT0023-58 MT0023-58 MT0023-58	C	4,800.00	4,800.00	0.00
	6/1/21	PART 77 OBSTRUCTION REMOVAL Hanover County Community Services	6559	2/1/21 5/10/21	MT0023-59	C	2,240.00	2,240.00	0.00
HUMMEL FIELD (T 65%, F 67%) 96,500.00	11/1/20	FY21 AWOS INSP & REPAIR Middlesex County Middlesex County	6174 6475	7/1/20 11/2/20 3/29/21	MT0076-69 MT0076-69 MT0076-69		3,500.00	1,140.00 1,140.00	1,220.00
	3/1/21	AWOS REPAIR Middlesex County	6373	11/4/20 2/16/21	MT0076-70 MT0076-70	C	1,970.45	1,970.45	0.00
	9/1/21	2021 WEEDKILL APPLICATION		5/27/21	MT0076-71		780.00		780.00
INGALLS FIELD (T 80%, F 67%) 88,740.40	11/1/20	FY20 AWOS INSP & REPAIR Bath County Airport Authority	6181	7/1/19 11/4/20	MT0024-96 MT0024-96 MT0024-96	C	3,150.00 (15.00)	1,045.00	2,090.00
	11/1/20	DISTANCE TO GO MAKER REPAIR Bath County Airport Authority	6182	12/4/19 11/4/20	MT0024-97 MT0024-97	C	3,501.60	3,501.60	0.00
	11/1/20	REIL - TROUBLESHOOT AND REPAIR FINAL DECREASE - SP Bath County Airport Authority	6183	12/4/19 11/2/20 11/4/20	MT0024-98 MT0024-98 MT0024-98	C	1,264.00 (141.00)	1,123.00	0.00
	9/1/21	FY21 AWOS INSP & REPAIR Bath County Airport Authority	6611	7/1/20 6/1/21	MT0024-01 MT0024-01		3,500.00	2,288.84	1,211.16
	6/1/21	MASTER REIL REPAIR Bath County Airport Authority	6610	12/8/20 6/1/21	MT0024-02 MT0024-02	C	2,551.78	2,551.78	0.00
LAKE ANNA 96,500.00	6/1/21	FY21 AWOS INSP & REPAIR Mile High Charters LLC Mile High Charters LLC FINAL - DECREASE Mile High Charters LLC	5909 6264 6482	7/1/20 7/16/20 12/15/20 3/30/21 4/5/21	MT9027-30 MT9027-30 MT9027-30 MT9027-30 MT9027-30	C	3,500.00	1,140.00 1,140.00 (80.00) 1,140.00	0.00
LAKE COUNTRY 96,445.85	9/1/21	FY21 AWOS INSP & REPAIR		7/1/20	MT9060-57		3,500.00		3,500.00
	3/31/21	AWOS OUTAGE REPAIR FINAL - DECREASE Lake County Airport Commission	6422	1/7/21 3/3/21 3/8/21	MT9060-58 MT9060-58 MT9060-58	C	1,273.00 (1,218.85)	54.15	0.00
LAWRENCEVILLE 96,500.00	6/1/21	FY21 AWOS INSP & REPAIR Brunswick County FINAL - DECREASE Brunswick County	6395 6591	7/1/20 3/2/21 5/18/21 5/24/21	MT9012-53 MT9012-53 MT9012-53 MT9012-53	C	3,500.00	1,710.00 855.00	0.00
		NEXT PROJECT							

AIRPORT	Expiration	DESCRIPTION / VO. PAYEE	VO. NO.	DATE	PROJ. #	AIRPORT ALLOCATION STATUS			
						ALLOCATION	EXPENDITURE	UNEXP. BALANCE	
LEE COUNTY 97,900.00	9/1/21	FY21 AWOS INSP & REPAIR FINAL - DECREASE		7/1/20 6/9/21	MT0084-31 MT0084-31	3,500.00 (1,600.00)		1,900.00	
	6/1/21	AIRFIELD ELECTRICAL FEED REPAIRS FINAL - DECREASE Lee County		9/2/20 3/11/21 3/19/21	MT0084-32 MT0084-32 MT0084-32	800.00 (600.00)	200.00	0.00	
LEESBURG 77,887.20	11/1/20	FY20 AWOS INSP & REPAIR closed per sponsor request 10/20/20 SS, SP verified		7/1/19	MT0027-97	965.00 (965.00)		0.00	
	6/1/21	FY21 AWOS INSP & REPAIR		7/1/20	MT0027-03	3,500.00		3,500.00	
	11/1/20	TERMINAL AIR CONDITIONING/HEATING UNIT REPLACEMENT CLOSED - SP Town of Leesburg		7/28/20 10/15/20 10/20/20	MT0027-04 MT0027-04 MT0027-04	17,540.80	17,540.80	0.00	
	11/1/20	TROUBLESHOOT ODALS CLOSED - SP Town Of Leesburg		7/28/20 10/15/20 10/20/20	MT0027-05 MT0027-05 MT0027-05	1,072.00	1,072.00	0.00	
	3/31/20	REPAIR ODAL LIGHTS CLOSED - SP Town Of Leesburg		9/2/20 12/3/20 12/7/20	MT0027-06 MT0027-06 MT0027-06	1,976.35	1,976.35	0.00	
	6/1/21	ASPHALT PATCH MATERIALS INCREASE FOR CORRECT FUNDING % - VC 20210408 Town Of Leesburg		1/22/21 4/8/21 4/12/21	MT0027-07 MT0027-07 MT0027-07	977.76 244.44	1,222.20	0.00	
	9/1/21	HERBICIDE TREATMENT - APRONS & FENCE		5/27/21	MT0027-08	2,240.00		2,240.00	
	LONESOME PINE (T 81%, F %) 96,020.00	3/1/21	RWY 6 PAPI EVALUATION FINAL - INCREASE (ALLOWABLE 10%) Cumberland Airport Commission		5/19/20 11/6/20 11/12/20	MT0060-42 MT0060-42 MT0060-42	480.00 48.00	528.00	0.00
		6/15/21	FY21 AWOS INSP & REPAIR FINAL - DECREASE		7/1/20 6/2/21	MT0060-43 MT0060-43	3,500.00 (246.25)		3,253.75
		11/1/20	SECURITY GATE REPAIR CLOSED - SP Cumberland Airport Commission		7/28/20 8/19/20 8/20/20	MT0060-44 MT0060-44 MT0060-44	372.20	372.20	0.00
3/1/21		RUNWAY LIGHTS TROUBLESHOOT FINAL Cumberland Airport Commission		10/9/20 10/15/20 10/20/20	MT0060-45 MT0060-45 MT0060-45	480.00	480.00	0.00	
3/1/21		RUNWAY LIGHTS REPAIR FINAL Cumberland Airport Commission		10/9/20 10/15/20 10/20/20	MT0060-46 MT0060-46 MT0060-46	723.60	723.60	0.00	
6/1/21		ROTATING BEACON REPAIR FINAL Cumberlands Airport Commission		1/22/21 2/9/21 2/16/21	MT0060-47 MT0060-47 MT0060-47	960.00	960.00	0.00	
6/1/21		RAMP LIGHTING REPAIR Cumberlands Airport Commission		2/11/21 3/19/21	MT0060-48 MT0060-48	910.55	910.55	0.00	
6/1/21		ROTATING BEACON REPAIR FINAL Cumberland Airport Commission		2/11/21 4/20/21 4/27/21	MT0060-49 MT0060-49 MT0060-49	2,940.00	2,940.00	0.00	
6/1/21		AWOS REPAIR FINAL Cumberlands Arport Commission		2/18/21 3/10/21 3/15/21	MT0060-50 MT0060-50 MT0060-50	4,237.00	4,237.00	0.00	
LOUISA 98,860.00		11/1/20	FY20 AWOS INSP & REPAIR INCREASE FINAL - SP Industrial Development Authority of Luisa County		7/1/19 9/29/20 10/1/20	MT0078-74 MT0078-74 MT0078-74	993.50 146.50	1,140.00	0.00

AIRPORT	Expiration	DESCRIPTION / VO. PAYEE	VO. NO.	DATE	PROJ. #	AIRPORT ALLOCATION STATUS			
						ALLOCATION	EXPENDITURE	UNEXP. BALANCE	
	6/1/21	FY21 AWOS INSP & REPAIR Industrial Development Authority	6361	7/1/20 2/9/21	MT0078-79 MT0078-79	C C	3,500.00	1,140.00 1,140.00	1,220.00
		Industrial Development Authority	6582	5/18/21	MT0078-79				
	11/1/20	MODIFICATION TO PCL FINAL DECREASE Industrial Development Authority Of Louisa County	6164	7/14/20 10/22/20 10/26/20	MT0078-80 MT0078-80 MT0078-80	C	1,162.40 (884.88)	277.52	0.00
	11/1/20	AIRPORT LIGHTING/TAXIWAY REIL OTS FINAL DECREASE Industrial Development Authority Of Louisa County	6179	8/6/20 11/2/20 11/2/20	MT0078-81 MT0078-81 MT0078-81	C	1,140.00 (154.48)	985.52	0.00
LUNEBURG 89,194.96	11/1/20	FY20 AWOS INSP & REPAIR FINAL - DECREASE County of Lunenburg Board of Supervisors	6084	7/1/19 9/28/20 10/1/20	MT0025-51 MT0025-51 MT0025-51	C	1,392.50 (513.75)	878.75	0.00
Obstructions mitigated 11/7/18	9/1/21	FY21 AWOS INSP & REPAIR		7/1/20	MT0025-52		3,500.00		3,500.00
	11/1/20	AWOS REPAIR FINAL County of Lunenburg Board of Supervisors	6083	8/6/20 9/28/20 10/1/20	MT0025-53 MT0025-53 MT0025-53	C	5,163.25	5,163.25	0.00
LURAY 94,417.65	6/1/21	FY21 AWOS INSP & REPAIR FINAL - DECREASE Proj# change to 40A due to the duplication during FY shift SS Luray Page County Airport Authority	6596	7/1/20 5/18/21 5/25/21	MT0067-40A MT0067-40A MT0067-40A	C	3,500.00 (80.00)	3,420.00	0.00
	11/1/20	SECURITY GATE GROUND LOOP REPAIR FINAL - DECREASE Luray Page County Airport Authority	5926	7/14/20 7/21/20 7/27/20	MT0067-41 MT0067-41 MT0067-41	C	195.88 (123.53)	72.35	0.00
	11/1/20	AWOS OUTAGE EVALUATION FINAL Luray Page County Airport	6004	8/6/20 8/20/20 8/27/20	MT0067-42 MT0067-42 MT0067-42	C	1,192.25	1,192.25	0.00
	3/1/20	AWOS OUTAGE REPAIR FINAL - DECREASE Luray Page County Airport	6201	10/1/20 11/10/20 11/12/20	MT0067-43 MT0067-43 MT0067-43	C	1,657.75 (760.00)	897.75	0.00
	6/1/21	AWOS WIND SENSOR REPAIR FINAL - DECREASE Luray Page County Airport Authority	6592	1/22/21 5/18/21 5/24/21	MT0067-44 MT0067-44 MT0067-44	C	1,530.75 (950.00)	580.75	0.00
LYNCHBURG REGIONAL 100,000.00		NEXT PROJECT			MT0029-46		0.00		0.00
MANASSAS REGIONAL (F=?, T: 69.5%) 8,308.65	11/1/20	MAIN TERMINAL BUILDING ROOF (Bidding & Design) FINAL - INCREASE (ALLOWABLE 10%) City of Manassa	5910	12/12/19 7/13/20 7/16/20	MT0030-67 MT0030-67 MT0030-67	C	7,158.50 715.85	7,874.35	0.00
	6/1/21	TERMINAL BUILDING ROOF REPLACEMENT (Construction) 69.5% City of Manassas	6862	7/28/20 2/9/21	MT0030-69 MT0030-69		83,817.00	34,750.00	49,067.00
MECKLENBURG 70,663.24	11/1/20	RW 01 ODALS TROUBLESHOOT INCREASE FOR REPAIRS FINAL Mecklenburg Brunswick Reg Airport Authority	5911	4/8/20 5/19/20 7/13/20 7/16/20	MT0070-73 MT0070-73 MT0070-73 MT0070-73	C	600.00 700.00	1,300.00	0.00
	9/1/21	FY21 AWOS INSP & REPAIR FINAL - DECREASE		7/1/20 6/9/21	MT0070-74 MT0070-74		3,500.00 (460.00)		3,040.00
	11/1/20	AWOS CEILOMETER EVALUATION (95%) INCREASE FOR REPAIR FINAL Mecklenburg Brunswick Regional Airport	6068	7/14/20 8/6/20 9/21/20 9/24/20	MT0070-75 MT0070-75 MT0070-75 MT0070-75	C	1,192.25 5,445.94		6,638.19

AIRPORT	Expiration	DESCRIPTION / VO. PAYEE	VO. NO.	DATE	PROJ. #	AIRPORT ALLOCATION STATUS		
						ALLOCATION	EXPENDITURE	UNEXP. BALANCE
	11/1/20	WINDSOCK BREAKER TROUBLESHOOT FINAL Mecklenburg Brunswick Regional Airport	6069	8/6/20 9/21/20 9/24/20	MT0070-76 C MT0070-76 MT0070-76	600.00		0.00
	3/1/21	FUEL FARM MOTOR & COUPLING (67%) FINAL - ALLOWABLE 10% INCREASE Mecklenburg Brunswick Regional Airport Commission	6292	10/20/20 1/5/21 1/11/21	MT0070-77 C MT0070-77 MT0070-77	1,011.28 101.13	1,112.41	0.00
	3/1/21	PILOT CONTROL LIGHTING REGULATOR FINAL Mecklenburg Brunswick Regional Airport Commission	6293	10/20/20 1/5/21 1/11/21	MT0070-78 C MT0070-78 MT0070-78	1,209.13	1,209.13	0.00
	9/1/21	BEACON AND TWY LIGHT REPAIR INCREASE FOR ADDTL REPAIR		1/7/21 3/18/21	MT0070-79 MT0070-79	920.00 1,560.00		2,480.00
	9/1/21	AWOS TROUBLESHOOT FINAL		3/18/21 6/9/21	MT0070-80 MT0070-80	712.50		712.50
	9/1/21	FUEL FARM PULSER (67%)		5/27/21	MT0070-81	830.13		830.13
	9/1/21	WEEDKILL APPLICATION FINAL		5/27/21 6/9/21	MT0070-82 MT0070-82	3,234.40		3,234.40
	9/1/21	TERMINAL BLDG HVAC BOILER REPLACEMENT		5/27/21	MT0070-83	8,180.00		8,180.00
MIDDLE PENINSULA (T 70.2%, F 67%, W 53,114.88)	6/1/21	FY21 AWOS INSP & REPAIR Middle Pminsula Regional Airport Authority Middle Pminsula Regional Airport Authority Middle Pminsula Regional Airport Authority	6137 6457 6612	7/1/20 10/19/20 3/19/21 6/1/21	MT0057-36 C MT0057-36 MT0057-36 MT0057-36	3,500.00	1,140.00 1,140.00 1,140.00	80.00
	11/1/20	100LL HAND PUMP REPLACEMENT Middle Peninsula Regional Airport	5991	7/28/20 8/20/20	MT0057-37 C MT0057-37	115.23	115.23	0.00
	3/1/21	AIRFIELD LIGHTING REPAIRS CLOSED - SP Middle Peninsula Regional Airport	6294	10/9/20 1/6/21 1/11/21	MT0057-38 C MT0057-38 MT0057-38	1,344.00	1,344.00	0.00
	3/1/20	EVALUATE AWOS OUTAGE FINAL DECREASE - sp Middle Peninsula Regional Airport	6295	12/8/20 1/6/21 1/11/21	MT0057-39 C MT0057-39 MT0057-39	1,353.75 (950.00)	403.75	0.00
	12/31/21	TRACTOR REPLACEMENT		5/27/21	MT0057-40	29,550.00		29,550.00
	9/1/21	AWOS CPU CARD REPLACEMENT		5/27/21	MT0057-41	3,013.84		3,013.84
	9/1/21	Lighting Repairs		5/27/21	MT0057-42	1,864.00		1,864.00
	9/1/21	AV GAS PUMP REPAIR		5/27/21	MT0057-43	6,738.34		6,738.34
	9/1/21	KUBOTA TIRES		5/27/21	MT0057-44	355.96		355.96
MOUNTAIN EMPIRE (T 75.2%, F 67%) Identified 6/16/16 93,686.95	9/30/21	RWY 26 OBS REMOVAL (AIP)		9/20/17	MT0031-37	817.05		817.05
	11/1/20	FY20 AWOS INSP & REPAIR CLOSED AT AIRPORT REQUEST	C	7/1/19 9/21/20	MT0031-54 C MT0031-54	585.00 (585.00)		0.00
	9/1/21	FY21 AWOS INSP & REPAIR Smyth Wythe Airport Commission Smyth Wythe Airport Commission	6296 6567	7/1/20 1/11/21 5/10/21	MT0031-56 C MT0031-56 MT0031-56	3,500.00	855.00 855.00	1,790.00

AIRPORT	Expiration	DESCRIPTION / VO. PAYEE	VO. NO.	DATE	PROJ. #	AIRPORT ALLOCATION STATUS		
						ALLOCATION	EXPENDITURE	UNEXP. BALANCE
	6/1/21	OBSTRUCTION LIGHT WIRING REPAIR		10/1/20	MT0031-57	396.00		396.00
	3/1/21	PCL TROUBLESHOOT CLOSED - DISAPPROVED (WORK COMPLETED BEFORE APPROVAL)		12/8/20 1/7/21	MT0031-58 MT0031-58	320.00 (320.00)		0.00
	9/1/21	AIRFIELD SIGNAGE TROUBLESHOOT		5/27/21	MT0031-59	400.00		400.00
	9/1/21	AIRFIELD LIGHTING REPLACEMENT LAMPS		5/27/21	MT0031-60	1,200.00		1,200.00
NEW KENT (F: ?, F: 67%) 90,835.02	12/30/20	JOHN DEERE TS GATOR FINAL - DECREASE New Kent County Board of Supervisors	5907	2/3/20 7/13/20 7/16/20	MT0041-71 MT0041-71 MT0041-71	3,336.32 (39.71)		0.00
	6/1/21	FY21 AWOS INSP & REPAIR FINAL - DECREASE New Kent County Board Of Spervisors	6560	7/1/20 5/4/21 5/10/21	MT0041-75 MT0041-75 MT0041-75	3,500.00 (1,006.25)		0.00
	11/1/20	FUEL FARM GROUNDING REEL (67%) FINAL - DECREASE New Kent County Board of Supervisors	6104	7/14/20 10/6/20 10/8/20	MT0041-76 MT0041-76 MT0041-76	176.18 (16.75)		0.00
	11/1/20	FUEL FARM CPS ANODE REPLACEMENT (67%) FINAL - DECREASE New Kent County Board of Supervisors	6105	7/28/20 10/6/20 10/8/20	MT0041-77 MT0041-77 MT0041-77	848.89 (193.63)		0.00
	11/1/20	WINDSOCK REPLACEMENT FINAL - DECREASE New Kent County Board of Supervisors	6106	7/28/20 10/6/20 10/8/20	MT0041-78 MT0041-78 MT0041-78	136.61 (15.68)		0.00
	11/1/20	VEEDER ROOT FLOAT KIT (67%) FINAL New Kent County Board of Supervisors	6119	8/6/20 10/6/20 10/14/20	MT0041-79 MT0041-79 MT0041-79	341.71		0.00
	6/1/21	ROTATING BEACON TROUBLESHOOT FINAL - DECREASE New Kent County Board of Supervisors	6505	1/7/21 4/13/21 4/19/21	MT0041-80 MT0041-80 MT0041-80	1,752.63 (157.84)		0.00
	3/1/21	FUEL FARM MONITORING SYSTEM REPAIR (67%) CLOSED AT AIRPORT REQUEST		1/7/21 1/20/21	MT0041-81 MT0041-81	204.89 (204.89)		0.00
	9/1/21	FUEL FARM CARD READER REPLACEMENT FINAL		2/11/21 6/2/21	MT0041-82 MT0041-82	502.50		502.50
NEW LONDON 100,000.00 Missing State Funding Annual Report		NEXT PROJECT			MT9083-03			0.00
NEW MARKET 92,175.64	11/1/20	FY20 AWOS INSP & REPAIR Increase Final - SP Robert O Thomas	6178	7/1/19 11/2/20 11/2/20	MT9084-28 MT9084-28 MT9084-28	965.00 175.00		0.00
	6/1/21	FY21 AWOS INSP & REPAIR Robert O Thomas	6568	7/1/20 5/10/21	MT9084-29 MT9084-29	3,500.00		0.00
	11/1/20	EVAL AWOS OUTAGE sponosr notified not needed 11/2/20 SS		9/2/20	MT9084-30	1,192.25 (1,192.25)		0.00
	3/1/21	2021 AWOS REPAIRS DECREASE FINAL - SP Robert O Thomas	6297	11/4/20 1/6/21 1/11/21	MT9084-31 MT9084-31 MT9084-31	8,106.32 (4,921.96)		0.00
NEWPORT NEWS 100,000.00		NEXT PROJECT			MT0035-23	0.00		0.00
NEW RIVER VALLEY 95,360.00	11/1/20	FY20 AWOS INSP & REPAIR New River Valley A/P Commission	5879	7/1/19 7/1/20	MT0012-20 MT0012-20	1,140.00		0.00

AIRPORT	Expiration	DESCRIPTION / VO. PAYEE	VO. NO.	DATE	PROJ. #	AIRPORT ALLOCATION STATUS			
						ALLOCATION	EXPENDITURE	UNEXP. BALANCE	
	6/1/21	FY21 AWOS INSP & REPAIR New River Valley A/P Commission	6593	7/1/20 5/24/21	MT0012-27 MT0012-27	C	3,500.00	2,383.85	1,116.15
NORFOLK 100,000.00		NEXT PROJECT			MT0036-33		0.00		0.00
ORANGE COUNTY 90,902.65	11/1/20	FY20 AWOS INSP & REPAIR INCREASE FOR ALLOW 95% - VC County of Orange	6046	7/1/19 9/16/20 9/17/20	MT0037-96 MT0037-96 MT0037-96	C	965.00 175.00	1,140.00	0.00
	6/1/21	FY21 AWOS INSP & REPAIR County of Orange	6615	7/1/20 6/1/21	MT0037-98 MT0037-98	C	3,500.00	3,420.00	80.00
	6/1/21	EVAL ROTATING BEACON CLOSED - SP County of Orange	6613	1/22/21 5/25/21 6/1/21	MT0037-99 MT0037-99	C	1,184.00	1,184.00	0.00
	6/1/21	EVAL AWOS VHF RADIO Closed at airport request per 3/19/21 email SS		2/11/21	MT0037-01	W	1,002.25 (1,002.25)		0.00
	6/1/21	REIL REPAIR EVAL CLOSED - SP County of Orange	6614	4/1/21 5/25/21 6/1/21	MT0037-02 MT0037-02 MT0037-02	C	912.00	912.00	0.00
	9/1/21	AWOS SURGE SUPPRESSOR		5/27/21	MT0037-03		1,022.58		1,022.58
	9/1/21	REPAIR AWOS VHF RADIO		5/27/21	MT0037-04		1,338.77		1,338.77
RICHMOND 100,000.00		NEXT PROJECT			MT0043-91		0.00		0.00
ROANOKE		NEXT PROJECT			MT0045-56		0.00		0.00
SHANNON NO MASTER AGREE/RECORDED CLDT 93,350.00 Missing State Funding Annual Report	6/1/20	FY20 AWOS INSP & REPAIR NO REIMBURSEMENT TILL MASTER AGREEMENT IS RECEIVED		7/1/19	MT9016-65		3,150.00		3,150.00
	6/1/21	FY21 AWOS INSP & REPAIR NO REIMBURSEMENT TILL MASTER AGREEMENT IS RECEIVED		7/1/20	MT9016-66		3,500.00		3,500.00
		NEXT			MT9016-67		0.00		0.00
SHENANDOAH VALLEY 100,000.00		NEXT PROJECT			MT0049-46		0.00		0.00
SMITH MT. LAKE (T: 91.2%, F: %) 98,640.00	3/1/20	2020 TREE REMOVAL CLOSED - SP Smith Mountain Lake Airport	6224	10/21/20 11/30/20 11/30/20	MT9040-31 MT9040-31 MT9040-31	C	1,360.00	1,360.00	0.00
STAFFORD 95,360.80	11/1/20	FY20 AWOS INSP & REPAIR CLOSED - SP		7/1/19 5/5/21	MT0069-64 MT0069-64	C	965.00 (965.00)		0.00
	6/1/21	FY21 AWOS INSP & REPAIR		7/1/20	MT0069-65		3,500.00		3,500.00
	3/1/21	RWY TXY LIGHTING CONTROL ISSUE CLOSED - SP Stafford Regional Airport Authority	6225	11/4/20 11/30/20 11/30/20	MT0069-66 MT0069-66 MT0069-66	C	1,139.20	1,139.20	0.00
	6/1/21	RUNWAY TAXIWAY LIGHT REPAIR		12/8/20	MT0069-67		2,007.72		2,007.72
SUFFOLK FF: 33% 96,500.00	9/1/21	FY21 AWOS INSP & REPAIR City of Suffolk	6594	7/1/20 5/24/21	MT0050-53 MT0050-53		3,500.00	2,280.00	1,140.00

AIRPORT	Expiration	DESCRIPTION / VO. PAYEE	VO. NO.	DATE	PROJ. #	AIRPORT ALLOCATION STATUS		
						ALLOCATION	EXPENDITURE	UNEXP. BALANCE
		FINAL - DECREASE		6/9/21	MT0050-53	(80.00)		
		NEXT PROJECT	1,140.00					
TANGIER ISLAND 91,993.75	3/1/21	FY20 AWOS INSP & REPAIR Town of Tangier	5897	7/1/19 7/13/20	MT0051-13 MT0051-13	2,820.00	1,425.00	1,395.00
	6/1/21	FY21 AWOS INSP & REPAIR		7/1/20	MT0051-14	3,500.00		3,500.00
	6/15/21	EVALUATE AWOS NADIM ISSUES INCREASE ALLOCATION PER CORRECT QUOTE & FUND. % FINAL		4/1/21 4/21/21 6/2/21	MT0051-15 MT0051-15 MT0051-15	1,571.51 114.74		1,686.25
TAPPAHANNOCK-ESSEX 95,235.00	11/1/20	FY20 AWOS INSP & REPAIR INCREASE FINAL - SP Essex County Airport Authority	6081	7/1/19 10/1/20	MT0081-62 MT0081-62	3,150.00 175.00	3,325.00	0.00
	11/1/20	SECURITY CAMERA TROUBLESHOOT CLOSED - SP Essex County Airport Authority	6145	2/21/20 9/22/20 10/20/20	MT0081-66 MT0081-66 MT0081-66	1,440.00		0.00
	11/1/20	PAPI REPAIR CLOSED DECREASE - SP Essex County Airport Authority	6071	5/19/20 9/22/20 9/24/20	MT0081-67 MT0081-67 MT0081-67	2,112.45 (640.00)	1,472.45	0.00
	11/1/20	CEILOMETER REPLACEMENT CLOSED INCREASE - SP Essex County Airport Authority	6070	6/15/20 9/24/20	MT0081-68 MT0081-68	3,262.08 1,371.64	4,633.72	0.00
	6/1/21	FY21 AWOS INSP & REPAIR		7/1/20	MT0081-69	3,500.00		3,500.00
	3/1/20	2021 FUEL TANK REPAIR PERCENTAGE INCREASE CLOSED - SP Essex County Airport Authority	6246	11/4/20 12/3/20 12/7/20	MT0081-70 MT0081-70 MT0081-70	6,883.44 30.96	6,914.40	0.00
	6/1/21	EVAL PAPI 2021 Essex County Airport Authority	6561	1/22/21 5/10/21	MT0081-71 MT0081-71	844.00	844.00	0.00
	6/1/21	2021 PAPI BULBS		3/18/21	MT0081-72	523.29		523.29
TAZEWELL COUNTY (T 83%, F ?) Notified 9/20/17 of OBS off-airport 96,500.00	11/1/20	FY20 AWOS INSP & REPAIR Closed at airport request - email 9/7/20 SS		7/1/19 9/22/20	MT0053-03 MT0053-03	2,105.00 (2,105.00)		0.00
	6/1/21	FY21 AWOS INSP & REPAIR		7/1/20	MT0053-10	3,500.00		3,500.00
	9/1/21	REPLACE HMP 155 PAPI		5/27/21	MT0053-11	1,225.01		1,225.01
TWIN COUNTY (F - 67%, T -) 96,500.00	6/1/20	FY20 AWOS INSP & REPAIR CLOSED - SP		7/1/19 5/5/21	MT0020-34 MT0020-34	585.00 (585.00)		0.00
	6/1/21	FY21 AWOS INSP & REPAIR Twin County Airport Commission Twin County Airport Commission	6375 6583	7/1/20 2/16/21 5/18/21	MT0020-46 MT0020-46 MT0020-46	3,500.00	1,710.00 855.00	935.00
	11/1/20	2020 BEACON REPAIR Twin County Airport Commission	5121	9/2/20 10/14/20	MT0020-47 MT0020-47	845.60	845.60	0.00
	9/1/21	PAPI REPAIR		5/27/21	MT0020-48	2,590.40		2,590.40
VA. HIGHLANDS 88,380.75	11/1/20	FY20 AWOS INSP & REPAIR FINAL - INCREASE Virginia Highlands Airport Authority	5925	7/1/19 7/20/20 7/27/20	MT0001-57 MT0001-57 MT0001-57	1,060.00 80.00	1,140.00	0.00

AIRPORT	Expiration	DESCRIPTION / VO. PAYEE	VO. NO.	DATE	PROJ. #	AIRPORT ALLOCATION STATUS			
						ALLOCATION	EXPENDITURE	UNEXP. BALANCE	
		PAPI OUTAGE		5/19/20	MT0001-65	C	844.00		
		FINAL		6/24/20	MT0001-65				0.00
		Virginia Highlands Airport Authority	5880	7/1/20	MT0001-65			844.00	
	6/1/21	FY21 AWOS INSP & REPAIR		7/1/20	MT0001-66	C	3,500.00		
		FINAL - DECREASE		5/18/21	MT0001-66		(80.00)		0.00
		Virginia Highlands Airport Authority	6595	5/24/21	MT0001-66			3,420.00	
	11/1/20	9FT ROWSE SICKLE MOWER		8/6/20	MT0001-67	C	4,130.00		
		FINAL		9/11/20	MT0001-67				0.00
		Virginia Highlands Airport Authority	6047	9/17/20	MT0001-67			4,130.00	
	6/1/21	EVALUATE AWOS OUTAGE		2/11/21	MT0001-68	C	1,002.25		
		FINAL		3/3/21	MT0001-68				0.00
		Virginia Highlands Airport	6423	3/8/21	MT0001-68			1,002.25	
		EVALUATE AWOS OUTAGE		5/27/21	MT0001-69		1,083.00		
									1,083.00
VA. TECH (T: ?, F: 50%)	11/1/20	FY20 AWOS INSP & REPAIR		7/1/19	MT0002-49	C	1,140.00		
95,360.0		Virginia Tech/ Montgomery Regional	5881	7/2/20	MT0002-49			1,140.00	0.00
	6/1/21	FY21 AWOS INSP & REPAIR		7/1/20	MT0002-55	C	3,500.00		
		Virginia Tech Montgomery Regional Airport Authority	6138	10/19/20	MT0002-55			1,140.00	80.00
		Virginia Tech Montgomery Regional Airport Authority	6476	3/29/21	MT0002-55			1,140.00	
		Virginia Tech Montgomery Regional Airport Authority	6562	5/10/21	MT0002-55			1,140.00	
	11/1/20	AWOS BACKUP BATTERY REPLACEMENT		8/19/20	MT0002-56	C	164.69		
		Virginia Tech Montgomery Regional Airport Authority	6014	9/9/20	MT0002-56			164.69	0.00
	3/1/21	TROUBLESHOOT AWOS/UNICOM INTERFERENCE		11/4/20	MT0002-57	C	1,567.50		
		FINAL - sp		1/6/21	MT0002-57				0.00
		Virginia Tech Montgomery Regional Airport Authority	6298	1/11/21	MT0002-57			1,567.50	
	6/1/21	AWOS CPU POWER SUPPLY		1/22/21	MT0002-58	C	85.49		
		CLOSED - SP		2/17/21	MT0002-58				0.00
		Virginia Tech Montgomery Regional	6394	3/2/21	MT0002-58			85.49	
WAKEFIELD		NEXT PROJECT			MT9071-14		0.00		0.00
Obstruction mitigated 4/27/18									
100,000.00									
WARRENTON	11/1/20	FY20 AWOS INSP & REPAIR		7/1/19	MT0068-01	C	1,060.00		
75,150.86		FINAL - INCREASE (ALLOWABLE 10%)		10/1/20	MT0068-01		80.00		0.00
		Fauquier County	6110	10/8/20	MT0068-01			1,140.00	
	11/1/20	VEGETATION MANAGEMENT FY2020		7/1/19	MT0068-02	C	3,704.00		
		FINAL		10/1/20	MT0068-02				0.00
		Fauquier County	6111	10/8/20	MT0068-02			3,704.00	
	9/30/23	RUNWAY SEAL COAT & MARKING (8% STATE/FED. PROJECT)		10/3/19	MT0068-03		13,333.00		
		INCREASE (APPROVED BY CB/MF ON 4/24/20)		4/24/20	MT0068-03		994.00		1,509.58
		Fauquier County	6461	3/24/21	MT0068-03			12,817.42	
	11/1/20	RWY 33 PAPI REPAIR		3/9/20	MT0068-06	C	1,050.00		
		FINAL		10/1/20	MT0068-06				0.00
		Fauquier County	6112	10/8/20	MT0068-06			1,050.00	
	6/1/21	FY21 AWOS INSP & REPAIR		7/1/20	MT0068-07	C	3,500.00		
		FINAL - DECREASE		5/6/21	MT0068-07		(1,220.00)		0.00
		Fauquier County	6563	5/10/21	MT0068-07			2,280.00	
	6/1/21	RWY 15 PAPI REGULATOR EVALUATION		10/1/20	MT0068-08	C	844.00		
		INCREASE FOR REPAIR		3/18/21	MT0068-08		1,504.14		0.00
		FINAL		5/4/21	MT0068-08				
		Fauquier County	6564	5/10/21	MT0068-08			2,348.14	
	6/1/21	AWOS WIND SENSOR BEARING KIT		3/18/21	MT0068-09	C	405.65		
		FINAL		5/4/21	MT0068-09				0.00
		Fauquier County	6565	5/10/21	MT0068-09			405.65	

AIRPORT	Expiration	DESCRIPTION / VO. PAYEE	VO. NO.	DATE	PROJ. #	AIRPORT ALLOCATION STATUS		
						ALLOCATION	EXPENDITURE	UNEXP. BALANCE
WILLIAM M. TUCK 96,500.00	6/1/21	FY21 AWOS INSP & REPAIR		7/1/20	MT0047-47	3,500.00		3,500.00
WILLIAMSBURG Monitor Airport Condition 88,971.10	11/1/20	FY20 AWOS INSP & REPAIR FINAL DECREASE - SP Williamsburg Jamestown Airport Inc	6175	7/1/19 11/2/20 11/2/2020	MT9010-62 MT9010-62 MT9010-62	1,122.22 (172.22)	950.00	0.00
	11/1/20	AIRSIDE EXTERIOR SIGN REPLACEMENT CLOSED - SP Williamsburg Jamestown Airport Inc	5938	1/30/20 7/29/20 7/30/20	MT9010-66 MT9010-66 MT9010-66	1,586.90	1,586.90	0.00
	6/1/20	PARKING LOT LIGHTS Williamsburg Jamestown Airport Inc	5898	3/17/20 7/13/20	MT9010-69 MT9010-69	3,920.00	3,920.00	0.00
	6/1/21	FY21 AWOS INSP & REPAIR Williamsburg Jamestown Airport Inc	6566	7/1/20 5/10/21	MT9010-70 MT9010-70	3,500.00	950.00	2,550.00
	11/1/20	AWOS OUTAGE EVAL. INCREASE PER CORRECT FUNDING % - VC Williamsburg Jamestown Airport Inc	5968	7/14/20 8/7/20 8/10/20	MT9010-71 MT9010-71 MT9010-71	1,072.00 201.00	1,273.00	0.00
	11/1/20	AWOS TEMP PROBE REPAIR INCREASE CLOSED - SP Williamsburg Jamestown Airport Inc	6108	7/28/20 9/22/20 10/8/20	MT9010-72 MT9010-72 MT9010-72	1,048.00 196.50	1,244.50	0.00
	11/1/20	AWOS VISIBILITY SENSOR REPLACEMENT INCREASE CLOSED - SP Williamsburg Jamestown Airport Inc	6109	7/28/20 9/22/20 10/8/20	MT9010-73 MT9010-73 MT9010-73	1,216.00 228.00	1,444.00	0.00
	6/1/21	AWOS WIND SENSOR BEARING KIT closed - sp Williamsburg Jamestown Airport Inc	6525	3/18/21 4/13/21 4/27/21	MT9010-74 MT9010-74 MT9010-74	1,118.15	1,118.15	0.00
WINCHESTER 92,806.51	11/1/20	FY20 AWOS INSP & REPAIR Allowable increase to cover incr in insp costs - VC Winchester Regional Airport Authority	5912	7/1/19 7/15/20 7/16/20	MT0059-23 MT0059-23 MT0059-23	1,060.00 80.00	1,140.00	0.00
	11/1/20	TAXIWAY "A" SEAL COAT (8% STATE/ FED. PROJECT) Winchester Regional Airport Authority Final SS	5882	7/17/19 7/2/20	MT0059-24 MT0059-24	12,056.00	6,053.49	0.00
	9/1/21	FY21 AWOS INSP & REPAIR Winchester Regional Airport Winchester Regional Airport	6424 6477	7/1/20 3/8/21 3/29/21	MT0059-28 MT0059-28 MT0059-28	3,500.00	1,140.00 1,140.00	1,220.00
	9/30/21	REBUILT ENGINE for 1996 New Holland Versatile Tractor SP Increase due to parts and labor Winchester Regional Airport Winchester Regional Airport	6425	10/15/20 12/8/20 3/8/21	MT0059-29 MT0059-29 MT0059-29	10,030.00 1,171.11	11,033.00	168.11
TOTAL TA BALANCE AS OF REPORT DATE								257,248.93
TOTAL EXPENDITURES AS OF APRIL 2021							412,471.91	
TOTAL ALLOCATIONS AS OF REPORT DATE						669,720.84		
APPROPRIATIONS UNALLOCATED						330,279.16		
TEST CHECK						0.00		July
Susan is purple: purple expiration date is extension C confirms closing cross-check D confirms denied in closing cross-check W confirms withdrawal in closing cross-check						check	669,720.84	257,248.93
						40,190.95 14,226.44	Cardinal Check July Aug	

CONTRACT/GRANT DOLLARS													
04/30/21 ANJ													
DEPARTMENT OF AVIATION													
FACILITIES AND EQUIPMENT PROGRAM													
No Funds Allocations and Expenditures													
Other issues For the FYE June 30, 2021													
AIRPORT ALLOCATION STATUS													
AIRPORT	DESCRIPTION / VO. PAYEE	Vo. #	DATE	W.O. #	ALLOCATION	EXPENDITURE	UNEXP. BALANCE	REVIEW					
ORIGINAL APPROPRIATION 2020-2021					1,400,000.00								
PLUS: PRIOR YEAR O/S COMMITMENTS					XXXXXX								
TOTAL APPROPRIATION FY '21					1,400,000.00								
1	ACCOMACK COUNTY	NEXT PROJECT			FE0033-56	0.00		0.00					
2	BLACKSTONE AAF	NEXT PROJECT			FE0008-07	0.00		0.00					
3	BLUE RIDGE	NEXT PROJECT			FM0032-49	0.00		0.00					
4	BRIDGEWATER AIRPARK OBS OFF-SITE 9/15/16	NEXT PROJECT			FE9072-10	0.00		0.00					
5	BROOKNEAL/CAMPBELL	NEXT PROJECT			FM0062-11	0.00		0.00					
6	CHARLOTT-ALBEMARLE	NEXT PROJECT			FE0004-12	0.00		0.00					
7	CHASE CITY MUNI	NEXT PROJECT			FM0005-03	0.00		0.00					
8	CHESAPEAKE REGIONAL	MALSR REPAIRS AND ALIGNMENT		04/23/19	FE0006-59	2,946.27		2,946.27					
	CO	NAVAID GENERATOR MAINTENANCE		3/2/20	FM0006-63	C 1,200.00							
		FINAL - INCREASE (ALLOWABLE 10%)		3/3/21	FM0006-63	29.76		0.00					
		Chesapeake Airport Authority	6418	3/8/21	FM0006-63		1,229.76						
		NAVAID BUILDING REPAIRS - SHINGLES 100% VC			FM0006-65	300.00		300.00					
9	CHESTERFIELD COUNTY	NEXT PROJECT			FM0007-39	C 0.00		0.00					
10	CREWE MUNICIPAL	NEXT PROJECT			FE9065-06	0.00		0.00					
11	CULPEPER REGIONAL	4-BOX PAPI RWY 04		2/20/20	FE0010-17	C 28,082.11							
		INCREASE - ADDED 6/15/20 SP		6/15/20	FE0010-17	1,886.56		0.00					
		County of Culpeper	5954	8/6/20	FE0010-17		29,968.67						
12	DANVILLE RGNL	NEXT PROJECT			FM0011-26	0.00		0.00					
13	DINWIDDIE COUNTY	NEXT PROJECT			C FM0039-29	0.00		0.00					

CONTRACT/GRANT DOLLARS														
04/30/21 ANJ														
DEPARTMENT OF AVIATION														
FACILITIES AND EQUIPMENT PROGRAM														
No Funds Allocations and Expenditures For the FYE June 30, 2021														
Other issues														
AIRPORT ALLOCATION STATUS														
AIRPORT	DESCRIPTION / VO. PAYEE	Vo. #	DATE	W.O. #	ALLOCATION	EXPENDITURE	UNEXP. BALANCE	REVIEW						
14	DULLES INTL	NEXT PROJECT			XXXXXX.XX	0.00		0.00						
15	EAGLE'S NEST	NEXT PROJECT			FM9089-08	0.00		0.00						
16	EMPORIA-GREENVILLE RGNL	AWOS VISIBILITY SENSOR REPLACEMENT (95%) FINAL Emporia Greenville Airport	9/2/20 10/27/20 10/28/20	6167	FE0013-21 FE0013-21 FE0013-21	20,305.64		0.00		20,305.64				
17	FALWELL NO MASTER AGREEMENT	NEXT PROJECT			FE9073-03	0.00		0.00						
18	FARMVILLE RGNL	NEXT PROJECT			FM0015-40	0.00		0.00						
19	FRANKLIN MUNICIPAL Obst. Mitigated 7/17/19	NEXT PROJECT			FE0017-16	0.00		0.00						
20	FRONT ROYAL-WARREN CO	NEXT PROJECT			FM0019-05	0.00		0.00						
21	GORDONSVILLE MUNI.	NEXT PROJECT			FE9070-06	0.00		0.00						
22	GRUNDY MUNICIPAL	NEXT PROJECT			FE0022-07	0.00		0.00						
23	HAMPTON ROADS EXEC	INSTALL REPLACEMENT BEACON - CONSTRUCTION AND CONSTR ADMIN Hampton Roads Airport Hampton Roads Airport Hampton Roads Airport CLOSE per 20210201 discussion & email from Susan Simmers - VC	3/5/20 9/9/20 10/1/20 11/2/20 2/1/21	6015 6079 6180	FE0040-15 FE0040-15 FE0040-15 FE0040-15 FE0040-15	75,683.10		0.00		31,932.00 34,426.05 4,744.64 (4,580.41)				
24	HANOVER CO MUNI	NEXT PROJECT			FE0023-40	0.00		0.00						
26	HUMMEL FIELD (SALUDA) CO T	PAPI INSTALL (DESIGN)	9/20/17		FM0076-13	2,640.00		2,640.00						
		NEXT PROJECT			FM0076-17	0.00		0.00						
27	INGALL'S FIELD	NEXT PROJECT			FM0024-26	0.00		0.00						
28	LAKE ANNA	NEXT PROJECT			FM9027-12			0.00						
29	LAKE COUNTRY	NEXT PROJECT			FM9060-12	0.00		0.00						

CONTRACT/GRANT DOLLARS													
04/30/21 ANJ													
DEPARTMENT OF AVIATION													
FACILITIES AND EQUIPMENT PROGRAM													
No Funds Allocations and Expenditures													
Other issues For the FYE June 30, 2021													
AIRPORT ALLOCATION STATUS													
AIRPORT	DESCRIPTION / VO. PAYEE	Vo. #	DATE	W.O. #	ALLOCATION	EXPENDITURE	UNEXP. BALANCE	REVIEW					
30	LAWREN-BRUNS. MUNI				FM9012-10	0.00		0.00					
31	LEE COUNTY				FM0084-06	0.00		0.00					
32	LEESBURG EXECUTIVE					22,440.00							
			7/18/19		FE0027-44								
	Town of Leesburg	5913	7/20/20		FE0027-44		20,891.52						
	Town of Leesburg	6078	10/1/20		FE0027-44		1,548.48						
	INCREASE - PER C.O. DISCUSSION W J HART ON 20210201 - VC		2/1/21		FE0027-44	2,119.20							
	Town of Leesburg	6510	4/19/21		FE0027-44		2,119.00	0.20					
33	LONESOME PINE				FE0060-20	0.00		0.00					
34	LOUISA COUNTY					5,125.35							
	TAXIWAY LIGHTING SYSTEM - REBID & CONSTR		8/29/18		FE0078-24								
	CLOSE per 20210201 discussion & email from John Hart - VC		2/1/21		FE0078-24	(5,125.35)		0.00					
	NEXT PROJECT				FE0078-27	0.00		0.00					
35	LUNENBURG COUNTY				FE0025-03	0.00		0.00					
36	LURAY CAVERNS					2,718.35							
	AWOS CPU REPLACEMENT		10/1/20		FE0067-07			0.00					
	FINAL		1/5/21		FE0067-07								
	Luray Page County Airport	6291	1/11/21		FE0067-07		2,718.35						
37	LYNCHBURG REGIONAL				FE0029-XX	0.00		0.00					
38	MANASSAS REGIONAL				FM0030-31	0.00		0.00					
39	MECK-BRUNSWICK RGNL				FE0070-36	0.00		0.00					
40	MIDDLE PENINSULA RGNL				FE0057-21	0.00		0.00					
41	MOUNTAIN EMPIRE				FE0031-30	0.00		0.00					
	OBS OFF-SITE 6/16/16												
42	NEW KENT COUNTY				FM0041-15	0.00		0.00					
42	NEW LONDON				FE9083-01	0.00		0.00					
	NO MASTER AGREEMENT												
43	NEW MARKET				FE9084-03	0.00		0.00					
44	NEW. NEWS/WMSBG INTL				FE0035-22	0.00		0.00					

CONTRACT/GRANT DOLLARS													
04/30/21 ANJ													
DEPARTMENT OF AVIATION FACILITIES AND EQUIPMENT PROGRAM Allocations and Expenditures For the FYE June 30, 2021													
No Funds													
Other issues													
AIRPORT ALLOCATION STATUS													
AIRPORT	DESCRIPTION / VO. PAYEE	Vo. #	DATE	W.O. #	ALLOCATION	EXPENDITURE	UNEXP. BALANCE	REVIEW					
							0.00						
45	NEW RIVER VALLEY	NEXT PROJECT		FM0012-27	0.00		0.00						
46	NORFOLK INT'L	NEXT PROJECT		FE0036-17	0.00		0.00						
47	ORANGE COUNTY ONGOING OBS RWY 26	NEXT PROJECT		FE0037-18	0.00		0.00						
48	RICHMOND INT'L	NEXT PROJECT		FE0043-22	0.00		0.00						
49	ROANOKE REGIONAL	NEXT PROJECT		FE0045-05	0.00		0.00						
50	SHANNON NO MASTER AGREE/CLDT RECOR	NEXT PROJECT NO REIMBURSEMENT TILL MASTER AGREEMENT IS RECEIVED		FE9016-12	0.00		0.00						
51	SHENANDOAH VALLEY REG.	NEXT PROJECT		FE0049-35	0.00		0.00						
52	SMITH MOUNTAIN LAKE	NEXT PROJECT		FM9040-02	C	0.00	0.00						
53	STAFFORD RGNL	NEXT PROJECT		FE0069-16	0.00		0.00						
54	SUFFOLK MUNICIPAL	NEXT PROJECT		FE0050-39	0.00		0.00						
55	TANGIER ISLAND NO BASED AIRCRAFT SURVEY	NEXT PROJECT		FE0051-05	0.00		0.00						
56A	TAPPAHANNOCK-ESSEX	NEXT PROJECT		FE0081-30	0.00		0.00						
57	TAZEWELL COUNTY	NEXT PROJECT		FE0053-25	0.00		0.00						
58	TWIN COUNTY	NEXT PROJECT		FE0020-32	0.00		0.00						
59	VIRGINIA HIGHLANDS	NEXT PROJECT		FM0001-08	0.00		0.00						
60	VIRGINIA TECH	REPLACE LOCALIZER - EQUIP., INSTALL & FLT CHK	1/29/20	FE0002-52	183,000.00		183,000.00						
61	WAKEFIELD MUNICIPAL Obstructions	NEXT PROJECT		FE9071-02	0.00		0.00						

CONTRACT/GRANT DOLLARS														
04/30/21 ANJ														
DEPARTMENT OF AVIATION														
FACILITIES AND EQUIPMENT PROGRAM														
No Funds														
Allocations and Expenditures														
For the FYE June 30, 2021														
Other issues														
AIRPORT ALLOCATION STATUS														
AIRPORT	DESCRIPTION / VO. PAYEE	Vo. #	DATE	W.O. #	ALLOCATION	EXPENDITURE	UNEXP. BALANCE	REVIEW						
62	WARRENTON-FAUQUIER	AWOS RADIO REPAIR / REPLACEMENT			FM0068-24	0.00								
							0.00							
63	WILLIAMSBURG/JAMESTOWN Monitor APT Condition	REPAIR BAR VASI SYSTEM		10/1/19	FM9010-11	3,740.79		3,740.79	Begin 07-10					
64	WILLIAM TUCK/SOUTH BOSTON	NEXT PROJECT			FE0047-03	0.00								
								0.00						
65	WINCHESTER REGIONAL	NEXT PROJECT			FM0059-51	0.00								
								0.00						
DEPARTMENT OF AVIATION***** WAREHOUSE STOCK / REPAIR ITEMS														
			7/1/20		FE9999-01	5,000.00		5,000.00						
		AUSTIN ELECTRICAL CONSTR. - NAV. MAINT.	7/1/19		FE9999-02	107,768.72			(Remaining bal from P.O. EP3126807)					
		Ausrin Electrical Constrction	5860	7/1/20	FE9999-02		4,675.00	139,035.46						
		Ausrin Electrical Constrction	5861	7/1/20	FE9999-02		6,155.00							
		Ausrin Electrical Constrction	5862	7/1/20	FE9999-02		1,160.00							
		Ausrin Electrical Constrction	5863	7/1/20	FE9999-02		735.00							
		Ausrin Electrical Constrction	5885	7/9/20	FE9999-02		49.86							
		Ausrin Electrical Constrction	5905	7/16/20	FE9999-02		7,220.00							
		Ausrin Electrical Constrction	5906	7/16/20	FE9999-02		990.00							
		Ausrin Electrical Constrction	5939	7/30/20	FE9999-02		9,380.00							
		Ausrin Electrical Constrction	5957	8/6/20	FE9999-02		4,675.00							
		Ausrin Electrical Constrction	5987	8/20/20	FE9999-02		9,180.00							
		Ausrin Electrical Constrction	5988	8/20/20	FE9999-02		4,776.50							
		Ausrin Electrical Constrction	6019	9/9/20	FE9999-02		905.00							
		Ausrin Electrical Constrction	6040	9/16/20	FE9999-02		7,875.00							
		Ausrin Electrical Constrction	6041	9/16/20	FE9999-02		1,075.00							
		Ausrin Electrical Constrction	6042	9/16/20	FE9999-02		8,965.00							
		Ausrin Electrical Constrction	606	9/24/20	FE9999-02		12,315.00							
		Ausrin Electrical Constrction	6101	10/8/20	FE9999-02		6,375.00							
		Ausrin Electrical Constrction	6154	10/22/20	FE9999-02		4,675.00							
		Ausrin Electrical Constrction	6155	10/22/20	FE9999-02		820.00							
		Ausrin Electrical Constrction	6166	10/22/20	FE9999-02		8,720.00							
		Ausrin Electrical Constrction	6184	11/5/20	FE9999-02		905.00							
		Ausrin Electrical Constrction	6197	11/12/20	FE9999-02		5,960.00							
		INCREASE - added to meet existing P.O. amount - VC		11/12/20	FE9999-02	25,000.00								
		Ausrin Electrical Constrction	6204	11/12/20	FE9999-02		7,440.00							
		Ausrin Electrical Constrction	6219	11/20/20	FE9999-02		8,705.00							
		Ausrin Electrical Constrction	6220	11/20/20	FE9999-02		820.00							
		INCREASE - P.O. # EP3262468 - VC		12/3/20	FE9999-02	270,000.00								
		Ausrin Electrical Constrction	6257	12/15/20	FE9999-02		5,225.00							
		Ausrin Electrical Constrction	6258	12/15/20	FE9999-02		6,155.00							
		Ausrin Electrical Constrction	6260	12/15/20	FE9999-02		9,990.00							
		Ausrin Electrical Constrction	6266	12/15/20	FE9999-02		417.28							
		Ausrin Electrical Constrction	6267	12/15/20	FE9999-02		122.65							
		Ausrin Electrical Constrction	6283	1/7/21	FE9999-02		900.00							
		Ausrin Electrical Constrction	6284	1/7/21	FE9999-02		905.00							
		Ausrin Electrical Constrction	6285	1/7/21	FE9999-02		5,090.00							
		Ausrin Electrical Constrction	6342	1/28/21	FE9999-02		6,375.00							
		Ausrin Electrical Constrction	6387	2/25/21	FE9999-02		4,675.00							
		Ausrin Electrical Constrction	6388	2/25/21	FE9999-02		7,525.00							
		Ausrin Electrical Constrction	6389	2/25/21	FE9999-02		8,465.00							

CONTRACT/GRANT DOLLARS													
04/30/21 ANJ													
DEPARTMENT OF AVIATION													
FACILITIES AND EQUIPMENT PROGRAM													
No Funds													
Allocations and Expenditures													
For the FYE June 30, 2021													
Other issues													
AIRPORT ALLOCATION STATUS													
AIRPORT	DESCRIPTION / VO. PAYEE	Vo. #	DATE	W.O. #	ALLOCATION	EXPENDITURE	UNEXP. BALANCE	REVIEW					
	Ausrin Electrical Constrtuction	6390	2/25/21	FE9999-02		7,220.00							
	Ausrin Electrical Constrtuction	8391	0225/21	FE9999-02		1,075.00							
	Ausrin Electrical Constrtuction	6434	3/11/21	FE9999-02		7,350.00							
	Ausrin Electrical Constrtuction	6435	3/11/21	FE9999-02		8,850.00							
	Ausrin Electrical Constrtuction	6454	3/19/21	FE9999-02		11,090.00							
	Ausrin Electrical Constrtuction	6481	4/1/21	FE9999-02		7,010.00							
	Ausrin Electrical Constrtuction	6500	4/15/21	FE9999-02		7,010.00							
	Ausrin Electrical Constrtuction	6501	4/15/21	FE9999-02		106.97							
	Ausrin Electrical Constrtuction	6502	4/15/21	FE9999-02		7,220.00							
	Ausrin Electrical Constrtuction	6515	4/21/21	FE9999-02		4,260.00							
	Ausrin Electrical Constrtuction	6516	4/21/21	FE9999-02		415.00							
	Ausrin Electrical Constrtuction	6551	5/7/21	FE9999-02		7,600.00							
	Ausrin Electrical Constrtuction	6552	5/7/21	FE9999-02		4,675.00							
	Ausrin Electrical Constrtuction	6553	5/7/21	FE9999-02		925.00							
	Ausrin Electrical Constrtuction	6618	6/2/02	FE9999-02		8,530.00							
	DEAN KENNEDY - ILS TECH. SERV. - NAV. MAINT.		7/1/19	FE9999-03	45,005.00								
	ILS Technical Service	5865	7/1/20	FE9999-03		3,675.00	63,230.00		(Remaining bal from P.O. EP3113390)				
	ILS Technical Service	5958	8/6/20	FE9999-03		6,850.00							
	ILS Technical Service	6020	9/9/20	FE9999-03		5,725.00							
	ILS Technical Service	6100	10/8/20	FE9999-03		3,950.00							
	ILS Technical Service	6185	11/5/20	FE9999-03		4,590.00							
	INCREASE - P.O. # EP3262480 - VC		12/3/20	FE9999-03	70,000.00			24,790.00	ILS spent to date 12/9/20				
	ILS Technical Service	6259	12/15/20	FE9999-03		4,175.00							
	ILS Technical Service	6286	1/7/21	FE9999-03		3,675.00							
	ILS Technical Service	6368	2/11/21	FE9999-03		5,385.00							
	ILS Technical Service	6407	3/4/21	FE9999-03		5,840.00							
	ILS Technical Service	6487	4/8/21	FE9999-03		3,675.00							
	ILS Technical Service	6554	5/7/21	FE9999-03		4,235.00							
	SURVEY EQUIPMENT (cc. 541, ac 1311)		11/6/20	FE9999-55	540.00								
	SOUTHERN AVIONICS - NDB PARTS			FE9999-57	0.00			540.00					
	THALES - (AIRSYS ATM) - PARTS		7/1/20	FE9999-58	7,803.00			0.00					
	THALES - (AIRSYS ATM) - PARTS	5976	8/13/20	FE9999-58		4,013.00	4,194.00		(Remaining bal from two outstanding P.O.s in FY2				
	THALES - MON MONITOR REPAIR		9/21/20	FE9999-58	2,878.00								
	THALES - CONTROL PANEL		10/5/20	FE9999-58	3,800.00								
	Thales	6153	10/22/20	FE9999-58		2,878.00							
	THALES - NAVAID PARTS REPAIR		10/29/20	FE9999-58	8,461.00								
	Thales	6194	11/12/20	FE9999-58		1,900.00							
	Thales	6210	11/19/20	FE9999-58		1,900.00			Asked Alton these two are good 20210201				
	Thales	6432	3/11/21	FE9999-58		8,057.00							
	THALES - REPAIR 21-0019		3/24/21	FE9999-58	9,463.00								
	THALES - REPAIR 21-0019-01 (DECREASE)		4/30/21	FE9999-58	(3,846.00)								
	Thales	6603	5/26/21	FE9999-58		5,617.00							
	SELEX (OLD ARLENIA MARCONI SYSTEMS (ASII)) - PARTS		4/5/19	FE9999-59	5,000.00								
	SELEX RMN LOC BOARDS REPAIR		8/20/20	FE9999-59	1,525.00			5,000.00					
	Selex	6152	10/22/20	FE9999-59		1,525.00							
	UPS/FEDEX SHIPPING			FE9999-60	500.00								
	cc541 ac1212							500.00					
	AAR COOPER (MIC'S/Antenna's)			FE9999-62	0.00								
								0.00					

CONTRACT/GRANT DOLLARS														
04/30/21 ANJ														
DEPARTMENT OF AVIATION														
FACILITIES AND EQUIPMENT PROGRAM														
No Funds Allocations and Expenditures														
Other issues For the FYE June 30, 2021														
AIRPORT ALLOCATION STATUS														
AIRPORT	DESCRIPTION / VO. PAYEE	Vo. #	DATE	W.O. #	ALLOCATION	EXPENDITURE	UNEXP. BALANCE	REVIEW						
	PARK AIR INC. - AWOS TRANSCEIVER			FE9999-63	0.00		0.00							
	INTERNATIONAL CRYSTAL MANUF			FE9999-65	0.00		0.00							
	FAA DEPOT			FE9999-66	0.00		0.00							
	MCG SURGE PROTECTION			FE9999-67	0.00		0.00							
	AWOS DATA NETWORKING		7/1/20	FE9999-69	8,380.13				(Remaining bal from P.O. EP3067336)					
	RSINet	5884	7/9/20	FE9999-69		3,940.82		8,288.05						
	RSINet	6103	10/8/20	FE9999-69		3,554.64								
	RSINet	6318	1/14/21	FE9999-69		3,482.76								
	INCREASE PER P.O. EP3222716		1/20/21	FE9999-69	14,400.00				(P.O. issued on 20200817)					
	RSI Net	6503	4/15/21	FE9999-69		3,513.86								
	UNICOM RADIOS		7/1/20	FE9999-70	5,000.00			5,000.00						
	NAVAID BUILDING REPAIRS - LKU A/C		8/17/20	FE9999-71	1,440.00									
	(Expenditure added on 12-15-20 by VC - Proj No. wasn't added to P.O.)		9/15/20	FE9999-71		1,440.00		0.00						
	PVG - HVAC TROUBLESHOOTING - VC		4/14/21	FE9999-71	65.00									
	PVG - HVAC REPAIRS - VC		4/26/21	FE9999-71	250.00			495.00						
	PVG - HVAC REPAIRS - VC		4/30/21	FE9999-71	180.00									
	BIRD ELECTRONICS			FE9999-74	0.00			0.00						
	NAVAID COMPUTER SERVICE - VITA			FE9999-75	0.00			0.00						
	B R COMMUNICATIONS (UNICOMS)			FE9999-77	0.00			0.00						
	NAVAID BUILDINGS - TRANSPORT			FE9999-83	0.00			0.00						
	PUBLICATION SUBSCRIPTIONS		7/1/20	FE9999-84	152.00									
	(Expenditures added on 12-15-20 by VC - Proj No. wasn't added to P.O.)		7/15/20			31.38	V2	57.86						
			9/15/20			31.38								
			11/15/20			31.38								
	OPEN T.A. / GRANT BALANCE AS OF REPORT DATE							423,967.63						
	TOTAL EXPENDITURES AS OF SEPT 2020					507,308.59								
	TOTAL ALLOCATIONS AS OF REPORT DATE				931,276.22									
	APPROPRIATIONS UNALLOCATED				468,723.78			\$0.00	test check					
						58,903.58	July total							

DEPARTMENT OF AVIATION
RURAL AIRPORT RUNWAY REHAB STATUS

For the FYE June 30, 2021

as of July 1, 2020

No Funds

Other Issues

07/14/20 VC

AIRPORT	DESCRIPTION	DATE	PROJECT #	AIRPORT ALLOCATION STATUS		
				ALLOCATION	GRANT	TA BALANCE
BRIDGEWATER AIRPARK - OBS 9/15/16				0.00		
					0.00	0.00
CHASE CITY	Runway Rehabilitation (Prelim Design & Geotech)	4/1/20	RA0005-01	25,000.00		
					0.00	25,000.00
CREWE MUNICIPAL				0.00		
					0.00	0.00
EAGLES NEST				0.00		
					0.00	0.00
						0.00
FALWELL				0.00		
					0.00	0.00
GORDONSVILLE	Runway Rehabilitation (Constr)	3/23/2021	RA9070-01	445,000.00		
	Runway Rehabilitation (Constr)	4/7/2021	RA9070-01		445,000.00	0.00
HUMMEL FIELD				0.00		
					0.00	0.00
LAKE ANNA AIRPORT				0.00		
					0.00	0.00
LAWRENCEVILLE-BRUNSWICK				0.00		
					0.00	0.00
LUNENBURG COUNTY				0.00		
					0.00	0.00
NEW LONDON				0.00		
					0.00	0.00
NEW MARKET				0.00		
					0.00	0.00
SHANNON				0.00		
					0.00	0.00
SMITH MTN LAKE				0.00		
					0.00	0.00
TOTAL PLACED UNDER GRANT FY 2019				<u>470,000.00</u>	<u>445,000.00</u>	
OPEN T.A. BALANCE AT 07/01/19						<u>25,000.00</u>

DEPARTMENT OF AVIATION
RURAL AIRPORT RUNWAY REHAB STATUS

For the FYE June 30, 2021
as of July 1, 2020

No Funds

Other Issues

07/14/20 VC

AIRPORT ALLOCATION STATUS

AIRPORT	DESCRIPTION	DATE	PROJECT #	ALLOCATION	GRANT	TA BALANCE
---------	-------------	------	-----------	------------	-------	------------

A	B	C	D	E	F	G	H	I	J	K	L	M	N	O	P	Q	R	S	T	U	V	
1	DEPARTMENT OF AVIATION																					
2	AVIATION AND AIRPORTS PROMOTION PROGRAM																					
3	FYE June 30, 2021																					
4																						
5	ORIGINAL APPROPRIATION 2020-2021 (FY21)				\$225,000.00																	
6	PLUS PRIOR YEAR COMMITMENTS (FY20)				\$0.00																	
7	TOTAL APPROPRIATION				\$225,000.00																	
8	UNALLOCATED BALANCE FY20				\$10,000.00																	
9																						
10																						
11	Airport	Date	Grant No.	Description/Notes	Pre T/A Date	Pre T/A \$	T/A Date	T/A \$	Grant Date	Grant \$	Expenditure 1	Expenditure 2	Expenditure 3	Expenditure 4	Unexpended Balance	Carryover	Date	Voucher #	Returned to Fund	Grant Expiration	Final RSVP	Grant Closed
12	Accomack														\$0.00							
13	Charlottesville														\$0.00							
14	Culpeper														\$0.00							
15	Danville	9/3/2020	PR0011-04	Requested \$7500.00 but was able to scale the project to use \$6,605.87 that was available.	9/3/2020		9/3/2020		9/21/2020	\$6,605.87	\$6,537.00				\$68.87		5/6/2021	#6546		4/30/21	4/19/2021	
16	Front Royal Warren														\$0.00							
17	Hempden Roads														\$0.00							
18	Hummel Field	8/21/2020	PR0076-03		12/21/2020		8/21/2020	\$10,000.00							\$0.00							
19	Hot Springs														\$0.00							
20	Leesburg														\$0.00							
21	Lanesome Pine														\$0.00							
22	Louisa														\$0.00							
23	Lynchburg	12/12/2019	PR0029-03	CARRYOVER (original grant \$35,000.00 \$21,605.87(paid FY20) +\$13,394.13 (FY21 carryover)	12/18/2019		12/19/2019		2/4/2020	\$13,394.13	\$21,605.87	\$13,394.13					6/10/2020 09/10/2020	#5793 #6035	\$0.00	9/30/20	8/26/2020	1/15/2021
24	Mianus	8/28/2020	PR0030-03		8/26/2020		8/26/2020		9/23/2020	\$10,000.00	\$1,486.63				\$8,513.37		2/25/2021	#6385				
25	Mecklenburg Brunswick														\$0.00							
26	Middle Peninsula														\$0.00							
27	New Kent														\$0.00							
28	Newport News Williamsburg	8/25/2020	PR0035-04		8/25/2020		8/25/2020		8/25/2020	\$35,000.00	\$35,000.00				\$0.00		3/4/2021	#6410	\$0.00	5/14/21	3/2/2021	4/23/2021
29	Norfolk	8/25/2020	PR0036-03		8/25/2020		8/25/2020		9/12/2020	\$35,000.00					\$35,000.00							
30	Richmond Executive Chesterfield	9/1/2020	PR0007-03		9/1/2020	\$10,000.00									\$0.00					\$10,000.00	5/7/21 n/a	5/10/2021
31	Richmond International	8/21/2020	PR0043-03		8/21/2020		8/21/2020		9/15/2020	\$35,000.00					\$35,000.00							
32	Roanoke Blacksburg	8/21/2020	PR0045-06		8/21/2020		8/21/2020		9/27/2020	\$35,000.00	\$35,000.00				\$0.00		12/23/2020	#6277	\$0.00	5/14/21	11/19/2020	4/13/2021
33	Shenandoah Valley	8/21/2020	PR0049-04		8/21/2020		8/21/2020		9/24/2020	\$35,000.00	\$3,406.34	\$19,415.93			\$12,177.73		2/25/2021 05/06/2021	#6386, #6545		5/14/21		
34	Stafford														\$0.00							
35	Tappahamock-Essex														\$0.00							
36	Tazewell														\$0.00							
37	VA Highlands														\$0.00							
38	VA Tech/Montgomery														\$0.00							
39	Warrenton-Fauquier														\$0.00							
40	Winchester														\$0.00							
41															\$0.00							
42															\$0.00							
43															\$0.00							
44															\$0.00							
45															\$0.00							
46															\$0.00							
47															\$0.00							
48															\$0.00							
49															\$0.00							
50															\$0.00							
51															\$0.00							
52															\$0.00							
53															\$0.00							
54															\$0.00							
55															\$0.00							
56															\$0.00							
57															\$0.00							
58															\$0.00							
59															\$0.00							
60															\$0.00							
61															\$0.00							
62						\$10,000.00		\$10,000.00		\$205,000.00					\$90,759.95	\$0.00			\$10,000.00			

GENERAL AVIATION AIRPORTS - DISCRETIONARY FUNDS
RECOMMENDED PROJECTS

FUNDED

PRIORITY NO.	AIRPORT NAME	DESCRIPTION	FEDERAL AMOUNT	STATE DISCR. AMOUNT	LOCAL AMOUNT	TOTAL PROJECT AMOUNT
176	Virginia Tech - Montgomery Executive Airport	Localizer Access Road (Construction)	\$0.00	\$31,146.00	\$0.00	\$31,146.00
165	Lee County Airport	Crack Seal, Seal Coat, and Pavement Remarking	\$339,000.00	\$30,133.00	\$7,584.00	\$376,717.00
158	Mountain Empire Airport	Obstruction Lighting Replacement (Construction)	\$0.00	\$3,568.00	\$892.00	\$4,460.00
141	Twin County Airport	Terminal Building Security Cameras Replacement	\$0.00	\$3,577.00	\$398.00	\$3,975.00
129	Mountain Empire Airport	Obstruction Removal - ROFA Grading (Design)	\$247,500.00	\$22,000.00	\$5,500.00	\$275,000.00
122	Virginia Highlands Airport	Sinkhole & Drainage Repair (Design)	\$0.00	\$59,200.00	\$14,800.80	\$74,000.80
120	Virginia Tech - Montgomery Executive Airport	Box Hangar Site Preparation (Design)	\$0.00	\$42,445.00	\$10,612.00	\$53,057.00
105	Virginia Tech - Montgomery Executive Airport	Stormwater Pollution Prevention Plan Update	\$0.00	\$6,530.00	\$1,633.20	\$8,163.20
40	Grundy Municipal Airport	NPIAS Justification Study	\$0.00	\$129,213.00	\$32,303.00	\$161,516.00

Region: 1

GENERAL AVIATION AIRPORTS - DISCRETIONARY FUNDS
NOT RECOMMENDED PROJECTS

Not Recommended

PRIORITY NO.	AIRPORT NAME	DESCRIPTION	FEDERAL AMOUNT	STATE DISCR. AMOUNT	LOCAL AMOUNT	TOTAL PROJECT AMOUNT
154	New River Valley Airport	Taxiway Crack Seal	\$0.00	\$0.00	\$37,000.00	\$37,000.00
118	Virginia Tech - Montgomery Executive Airport	Terminal Parking Lot Expansion (Design)	\$0.00	\$0.00	\$53,556.00	\$53,556.00
REGION TOTALS:			\$586,500.00	\$327,812.00	\$164,279.00	\$1,078,591.00

COMMONWEALTH AVIATION FUND
 FUNDING REQUEST SUMMARY
 VAB DATE: 06/09/2021

Airport: Grundy Municipal Airport
 Region: 1
 Name: Mr. J. Jack Kennedy Jr.

Sponsor: Town of Grundy
 Contact: Mr. James Keen , Town Manager
 Phone: 276-935-2551

State Funding Summary		
	Requested	Recommended
Entitlement	\$0.00	\$0.00
Air Carrier/Reliever Discretionary	\$0.00	\$0.00
General Aviation Discretionary	\$129,213.00	\$129,213.00
TOTALS	\$129,213.00	\$129,213.00

Unmitigated Obstructions

Based Aircraft:	0
Annual Operations:	4,154
Service Role:	LO

Development Program Projects								
Description	Priority	Project Cost	Requested Funding			Recommended Funding		
			Federal	State	Local	Federal	State	Local
NPIAS Justification Study	40	\$161,516.00		\$129,213.00	\$32,303.00		\$129,213.00	\$32,303.00
TOTALS		\$161,516.00	\$0.00	\$129,213.00	\$32,303.00	\$0.00	\$129,213.00	\$32,303.00

Remarks: NPIAS Justification Study
 Staff recommends approval.

**AIRPORT CAPITAL IMPROVEMENT PROGRAM
PROGRAM NARRATIVE
BREAKS REGIONAL AIRPORT**

The following program narrative addresses the detailed project description and justification for the current funding submission.

1 NPIAS Justification Study

The former Grundy Municipal Airport (GDY) was closed in 2019 to remove coal located under the site of the airport. The intent is to replace the former airport with a new airport with a longer runway and improved facilities such as aprons, terminal building, and hangars. An Airport Layout Plan was developed in 2009 which depicted a 5,100-foot runway on the lower site elevation after mining activities. The current mining operation is being conducted so that the runway and associated facilities identified on the ALP can be constructed as planned.

When the Airport closed in 2019, it was removed from the National Plan of Integrated Airport Systems (NPIAS) which is the Federal Aviation Administration (FAA) database of all federally obligated airports. This study will identify methods for returning the new airport back in to the NPIAS in order to receive federal funds for the design and construction of the new facility.

Estimated Cost:	State (80%):	\$84,000
	Local (20%):	\$21,000

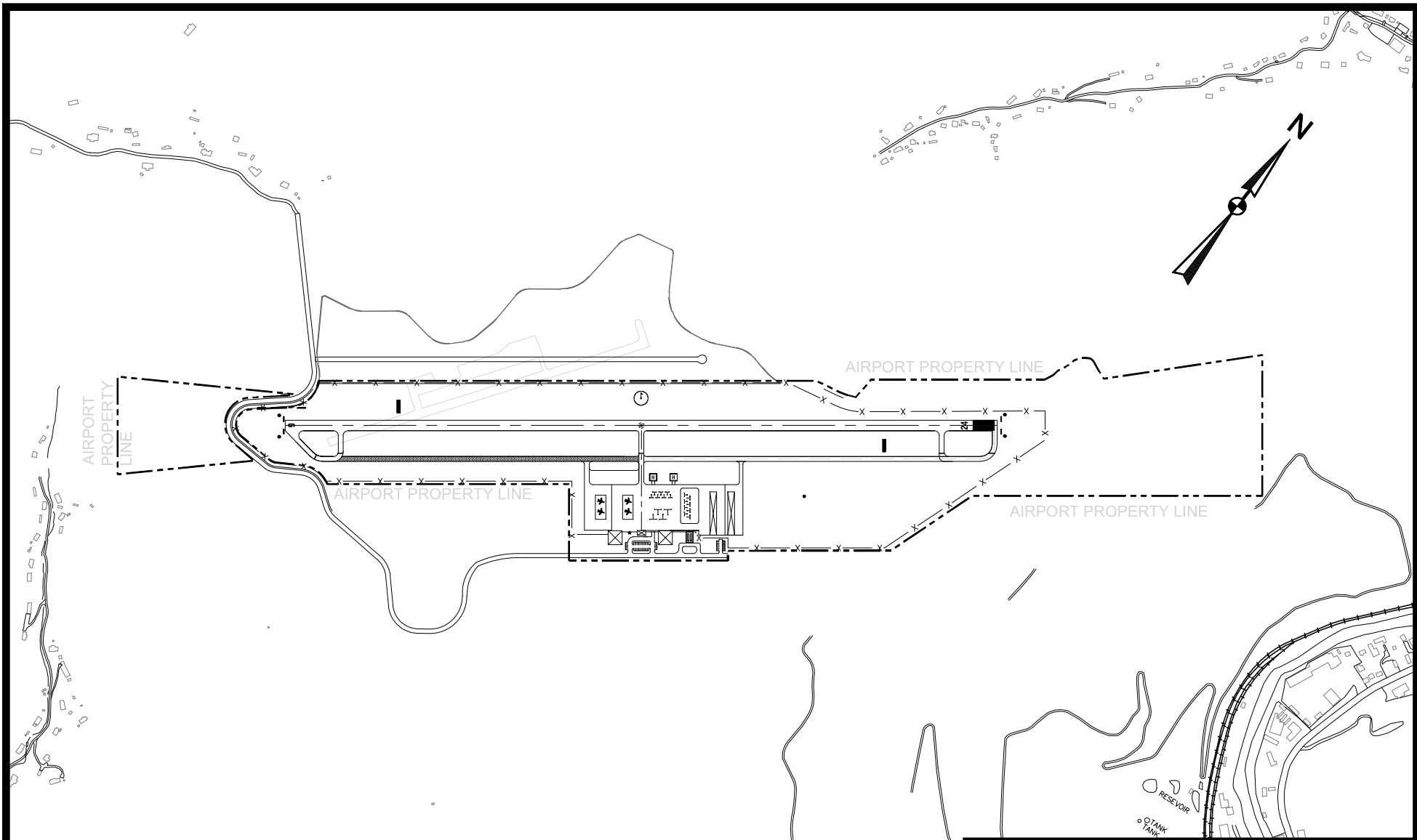

ACIP SKETCH
BREAKS REGIONAL AIRPORT (PROPOSED)
TALBERT & BRIGHT ENGINEERING & PLANNING CONSULTANTS 10105 KRAUSE ROAD, SUITE 100 CHESTERFIELD, VIRGINIA 23832 PHONE: 804-768-6878 FAX: 804-768-6871

COMMONWEALTH AVIATION FUND
 FUNDING REQUEST SUMMARY
 VAB DATE: 06/09/2021

Airport: Lee County Airport
 Region: 1
 Name: Mr. J. Jack Kennedy Jr.

Sponsor: County of Lee
 Contact: Mr. D. Dane Poe , County Administrator
 Phone: 276-346-7714

State Funding Summary		
	Requested	Recommended
Entitlement	\$0.00	\$0.00
Air Carrier/Reliever Discretionary	\$0.00	\$0.00
General Aviation Discretionary	\$30,133.00	\$30,133.00
TOTALS	\$30,133.00	\$30,133.00

Unmitigated Obstructions

Based Aircraft:	8
Annual Operations:	3,488
Service Role:	GC

Development Program Projects									
Projects			Requested Funding			Recommended Funding			
Description	Priority	Project Cost	Federal	State	Local	Federal	State	Local	
Crack Seal, Seal Coat, and Pavement Marking	165	\$376,717.00	\$339,000.00	\$30,133.00	\$7,584.00	\$339,000.00	\$30,133.00	\$7,584.00	
TOTALS		\$376,717.00	\$339,000.00	\$30,133.00	\$7,584.00	\$339,000.00	\$30,133.00	\$7,584.00	

Remarks: Crack Seal, Seal Coat, and Pavement Marking
 Staff recommends approval.

LEE COUNTRY AIRPORT

PROJECT NARRATIVE

**FISCAL YEAR 2021
June 2021 VAB Meeting**

The following narrative addresses the detailed project description and justification for the Airport Capital Improvement Plan

CRACK SEAL, SEAL COAT, AND REMARK AIRFIELD PAVEMENT PROJECT

The scope of this project includes the design, bidding, and construction administration phase services for the Crack Seal, Seal Coat, and Remark Airfield Pavement Project. The pavement is approaching 20 years; however, it is still in fair condition. This project is to preserve and extend the useful life of the airfield pavement.

Design and Construction are included in the same grant.

A CATEX has been approved for this project in April 2021.

Proposed Funding Allocation – FAA 90% State 8%, Local 2%

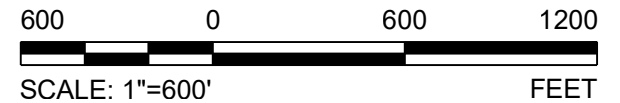
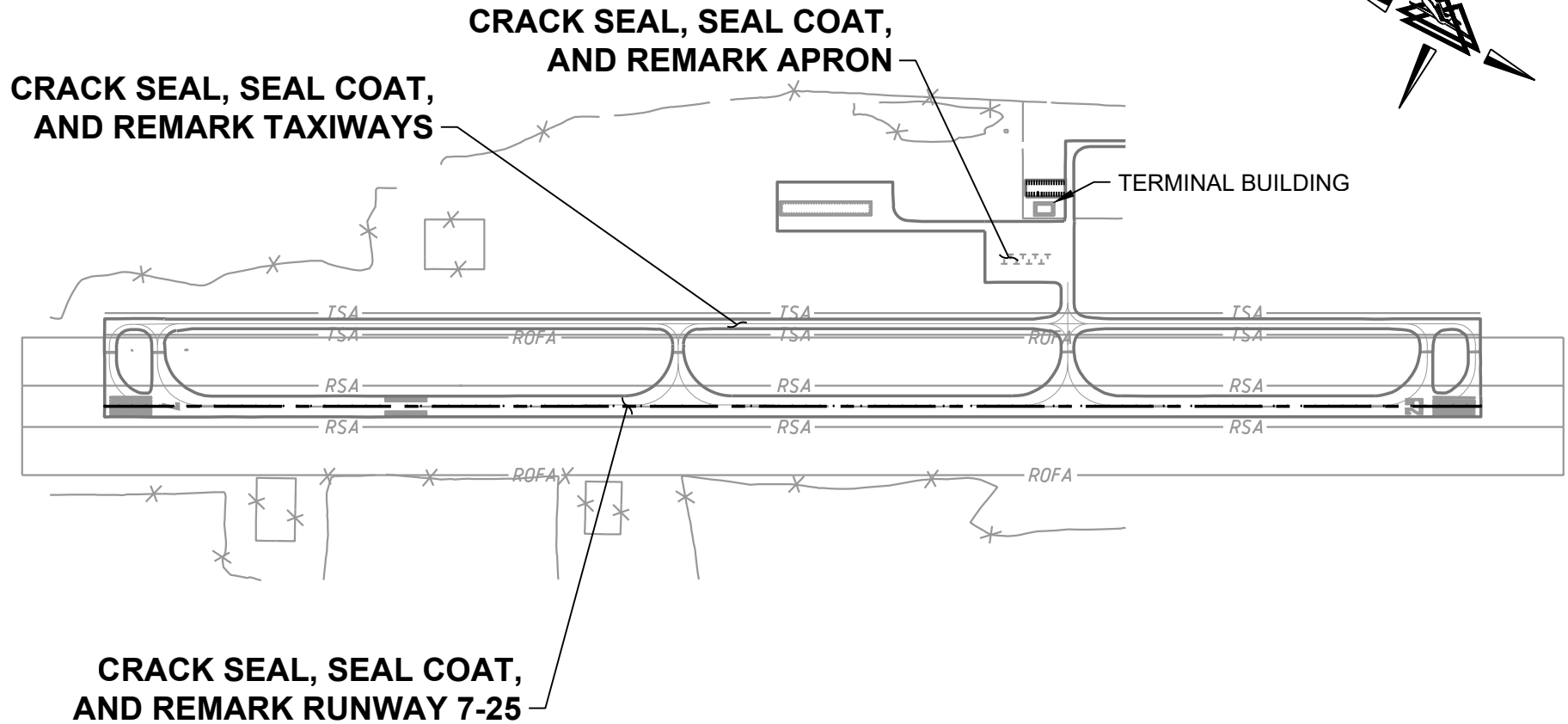
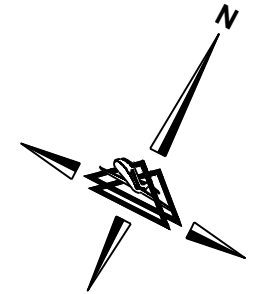

**PROJECT SCOPE EXHIBIT
LEE COUNTY AIRPORT**

**EXHIBIT
1**

COMMONWEALTH AVIATION FUND
 FUNDING REQUEST SUMMARY
 VAB DATE: 06/09/2021

Airport: Mountain Empire Airport
 Region: 1
 Name: Mr. J. Jack Kennedy Jr.

Sponsor: Smyth-Wythe Airport Commission
 Contact: Mr. Curtis Pennington , Chariman
 Phone: 276-686-0102

State Funding Summary		
	Requested	Recommended
Entitlement	\$0.00	\$0.00
Air Carrier/Reliever Discretionary	\$0.00	\$0.00
General Aviation Discretionary	\$25,568.00	\$25,568.00
TOTALS	\$25,568.00	\$25,568.00

Unmitigated Obstructions

Based Aircraft:	15
Annual Operations:	10,078
Service Role:	GR

Development Program Projects								
Description	Priority	Project Cost	Requested Funding			Recommended Funding		
			Federal	State	Local	Federal	State	Local
Obstruction Lighting Replacement (Construction)	158	\$4,460.00		\$3,568.00	\$892.00		\$3,568.00	\$892.00
Obstruction Removal - ROFA Grading (Design)	129	\$275,000.00	\$247,500.00	\$22,000.00	\$5,500.00	\$247,500.00	\$22,000.00	\$5,500.00
TOTALS		\$279,460.00	\$247,500.00	\$25,568.00	\$6,392.00	\$247,500.00	\$25,568.00	\$6,392.00

Remarks: Obstruction Lighting Replacement (Construction)
 Staff recommends approval.

Obstruction Removal - ROFA Grading (Design)
 Staff recommends approval.

MOUNTAIN EMPIRE AIRPORT

PROJECT NARRATIVE

FISCAL YEAR 2021

June 2021 VAB Meeting

The following narrative addresses the detailed project description and justification for the Airport Capital Improvement Plan

OBSTRUCTION REMOVAL AND ROFA GRADING

The scope of this project includes the design phase services for the removal of tree obstructions to the Runway 8 Approach Surfaces and the grading of terrain that currently penetrates the Runway Obstacle Free Zone (ROFZ) and Runway Object Free Area (ROFA) to maintain FAA design safety standards. The terrain removal/grading will likely require blasting due to the presence of rock in the area and will require significant coordination with VDOT. Construction funding will be requested under a separate grant.

A re-evaluation of 2013 EA/FONSI was completed for this project and approved on 3/24/2021.

Proposed Funding Allocation – FAA 90%, Other 10%

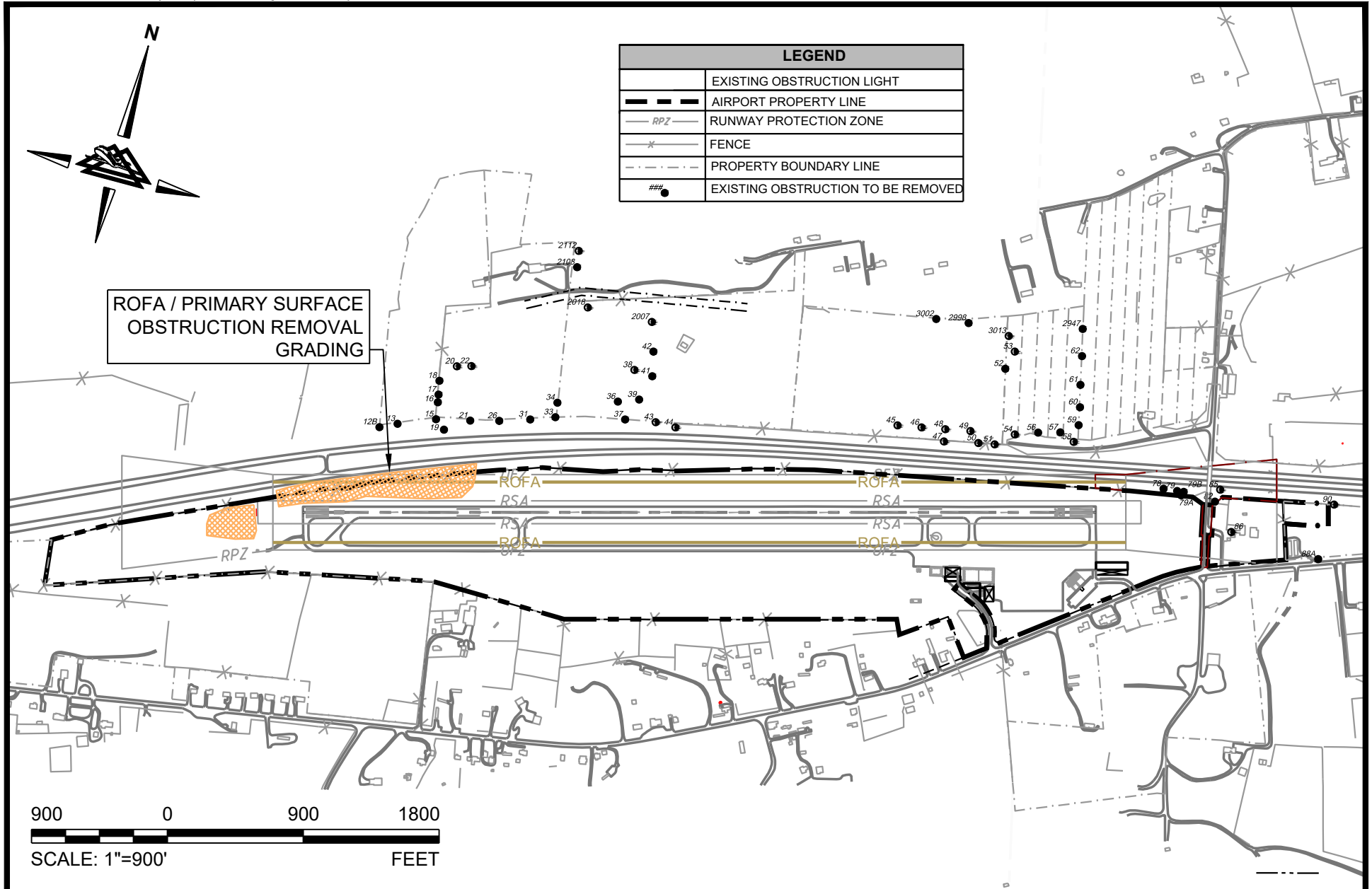

**PROJECT LAYOUT EXHIBIT
MOUNTAIN EMPIRE AIRPORT**

DRAWN BY: NYB CHECKED BY: TLB SCALE: 1" = 900' DATE: MAY 2021

**EXHIBIT
1**

Smyth-Wythe Airport Commission

Mountain Empire Airport

PROJECT NARRATIVE

FISCAL YEAR 2021

June 2021 VAB Meeting

Obstruction Lighting (Solar LED) (Construction)

The scope of this project includes replacement of the obstruction lights that are located off airport property on the other side of Interstate 81. The current obstruction lights have been problematic and the electrical service to the lights has had issues as well. The replacement of the current obstruction lights with solar LED should eliminate some of the issues that the airport is currently having and reduce the need for airport personnel to access the adjacent property owner's property.



COMMONWEALTH AVIATION FUND
 FUNDING REQUEST SUMMARY
 VAB DATE: 06/09/2021

Airport: New River Valley Airport
 Region: 1
 Name: Mr. J. Jack Kennedy Jr.

Sponsor: New River Valley Airport Commission
 Contact: Mr. Robert Glenn , Chairman
 Phone: 540-980-3434

State Funding Summary		
	Requested	Recommended
Entitlement	\$0.00	\$0.00
Air Carrier/Reliever Discretionary	\$0.00	\$0.00
General Aviation Discretionary	\$29,600.00	\$0.00
TOTALS	\$29,600.00	\$0.00

Unmitigated Obstructions

Based Aircraft:	35
Annual Operations:	6,805
Service Role:	GR

Development Program Projects									
Description	Priority	Project Cost	Federal	Requested Funding			Recommended Funding		
				State	Local	Federal	State	Local	
Taxiway Crack Seal	154	\$37,000.00		\$29,600.00	\$7,400.00		\$0.00	\$37,000.00	
TOTALS		\$37,000.00	\$0.00	\$29,600.00	\$7,400.00	\$0.00	\$0.00	\$37,000.00	

Remarks: Taxiway Crack Seal
 Staff recommends disapproval.
 The bids were submitted after the deadline.

To: Virginia Aviation Board
From: New River Valley Regional Airport
Date: January, 2021

REQUEST: Taxiway Crack-Seal

Description: The New River Valley Airport is seeking funding to maintain its parallel taxiway to the east that serves the RW 6 threshold. The pavement is in poor condition and is expected to be rehabilitated in three years. As such the crack seal is necessary to maintain the taxiway until the more comprehensive rehabilitation can be funded. This request is assuming 90% Federal, 8% State, and 2% local share.

Cost: The total project cost is \$37,000. As such this request is for State participation of \$2,960.

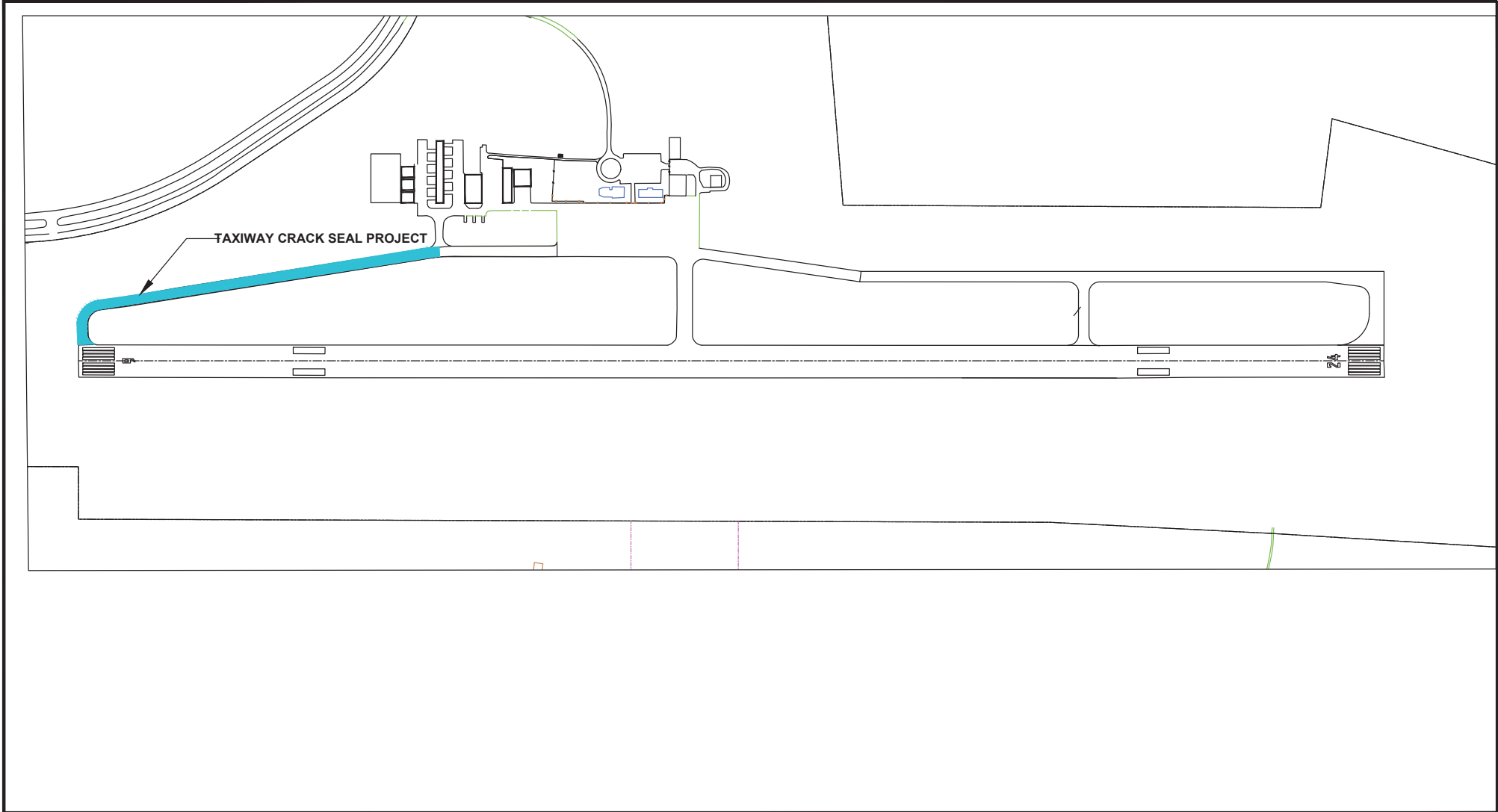

	NEW RIVER VALLEY AIRPORT	

COMMONWEALTH AVIATION FUND
 FUNDING REQUEST SUMMARY
 VAB DATE: 06/09/2021

Airport: Twin County Airport
 Region: 1
 Name: Mr. J. Jack Kennedy Jr.

Sponsor: Twin County Airport Commission
 Contact: Mr. Tom Jones , Chair
 Phone: 276-236-6473

State Funding Summary		
	Requested	Recommended
Entitlement	\$0.00	\$0.00
Air Carrier/Reliever Discretionary	\$0.00	\$0.00
General Aviation Discretionary	\$3,577.00	\$3,577.00
TOTALS	\$3,577.00	\$3,577.00

Unmitigated Obstructions

Based Aircraft:	21
Annual Operations:	8,830
Service Role:	GC

Development Program Projects								
Projects			Requested Funding			Recommended Funding		
Description	Priority	Project Cost	Federal	State	Local	Federal	State	Local
Terminal Building Security Cameras Replacement	141	\$3,975.00		\$3,577.00	\$398.00		\$3,577.00	\$398.00
TOTALS		\$3,975.00	\$0.00	\$3,577.00	\$398.00	\$0.00	\$3,577.00	\$398.00

Remarks: Terminal Building Security Cameras Replacement
 Staff recommends approval.

Twin County Airport Commission

Twin County Airport

Narrative

FY2021 Camera System Replacement

The terminal building security camera system is 8 years old and has been damaged beyond repair. The system is totally non-functional. Replacement parts are difficult to find and often expensive. The commission probably would be unable to find a hard drive, and if found, it would cost more than a new system.

All interior and exterior surveillance equipment needs to be replaced as follows:

- 9 - Hikvision 4mp IP Camera's
- 1 - 16 Channel 4TB Hard Drive Hikvision

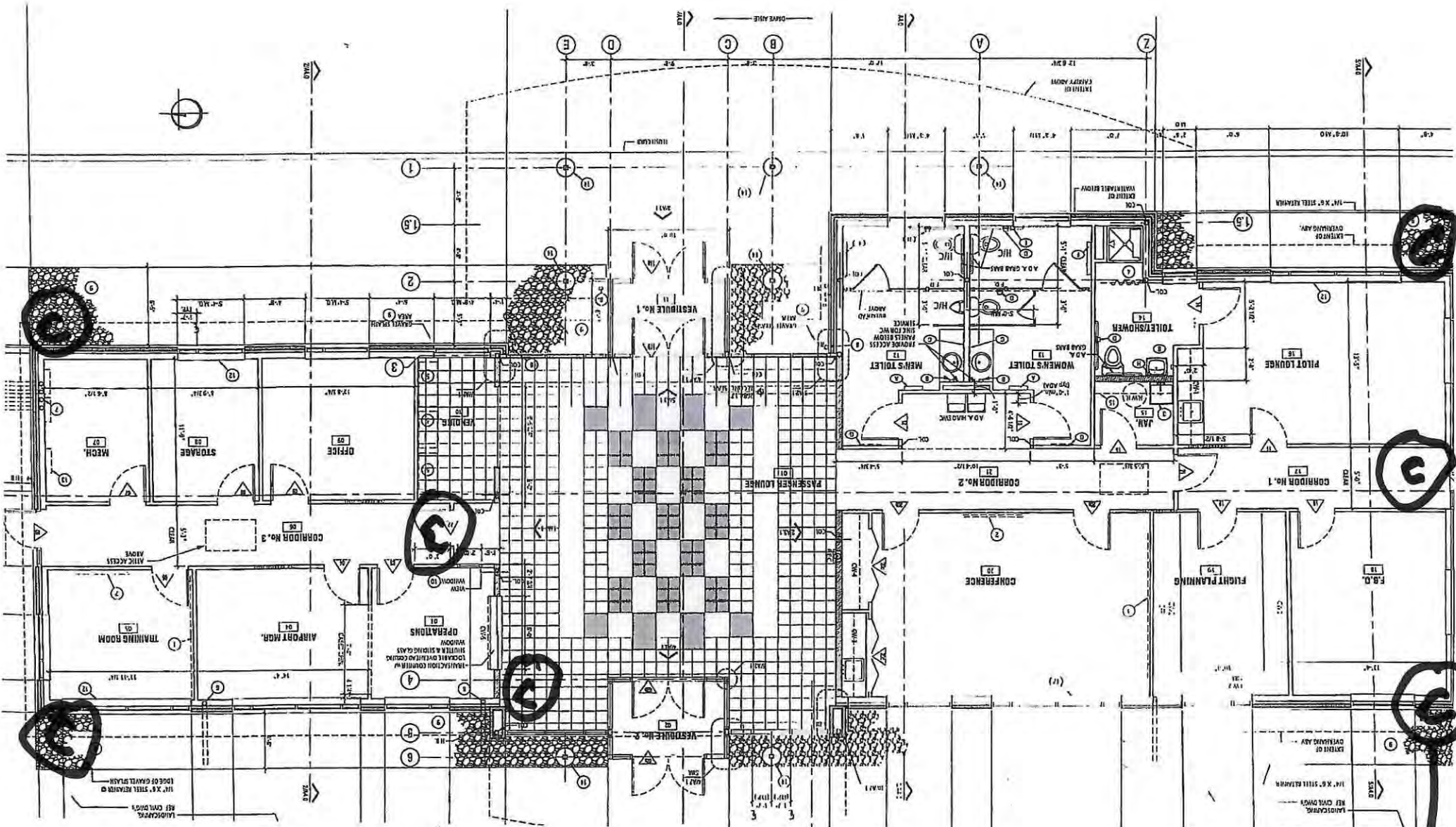

3-INTERIOR CAMERA'S
 6-EXTERIOR CAMERA'S

3

COMMONWEALTH AVIATION FUND
 FUNDING REQUEST SUMMARY
 VAB DATE: 06/09/2021

Airport: Virginia Highlands Airport
 Region: 1
 Name: Mr. J. Jack Kennedy Jr.

Sponsor: Virginia Highlands Airport Authority
 Contact: Mr. Mickey Hines , Airport Manager
 Phone: 276-628-2909

State Funding Summary		
	Requested	Recommended
Entitlement	\$0.00	\$0.00
Air Carrier/Reliever Discretionary	\$0.00	\$0.00
General Aviation Discretionary	\$59,200.00	\$59,200.00
TOTALS	\$59,200.00	\$59,200.00

Unmitigated Obstructions

Based Aircraft:	66
Annual Operations:	11,559
Service Role:	GR

Development Program Projects									
Projects			Requested Funding			Recommended Funding			
Description	Priority	Project Cost	Federal	State	Local	Federal	State	Local	
Sinkhole & Drainage Repair (Design)	122	\$74,000.80		\$59,200.00	\$14,800.80		\$59,200.00	\$14,800.80	
TOTALS		\$74,000.80	\$0.00	\$59,200.00	\$14,800.80	\$0.00	\$59,200.00	\$14,800.80	

Remarks: Sinkhole & Drainage Repair (Design)
 Staff recommends approval.

VIRGINIA HIGHLANDS AIRPORT

PROJECT NARRATIVE

**FISCAL YEAR 2021
March 2021 VAB Meeting**

The following narrative addresses the detailed project description and justification for the Airport Capital Improvement Plan

SINKHOLE REPAIR PROJECT

The scope of this project includes the design, bidding, and construction administration phase services for the repair of two major sink holes on the airfield. The sink holes have grown to the point of needing to be repaired to prevent them from growing any larger.

Construction funding will be requested under a separate grant.

No environmental was required for this project.

Proposed Funding Allocation –State 80%, Local 20%



Sink Hole Locations

Virginia Highlands Airport
April 2020

VAB Package June 17, 2021



COMMONWEALTH AVIATION FUND
FUNDING REQUEST SUMMARY
VAB DATE: 06/17/2021

Airport: Virginia Tech - Montgomery Executive Airport
Region: 1
Name: Mr. J. Jack Kennedy Jr.

Sponsor: Virginia Tech-Montgomery Regional Airport Authority
Contact: Mr. Keith Holt , Manager
Phone: 540-231-4444

State Funding Summary		
	Requested	Recommended
Entitlement	\$0.00	\$0.00
Air Carrier/Reliever Discretionary	\$0.00	\$0.00
General Aviation Discretionary	\$122,965.00	\$80,121.00
TOTALS	\$122,965.00	\$80,121.00

Unmitigated Obstructions

Based Aircraft:	50
Annual Operations:	21,755
Service Role:	GR

Development Program Projects								
Description	Priority	Project Cost	Requested Funding			Recommended Funding		
			Federal	State	Local	Federal	State	Local
Box Hangar Site Preparation (Design)	120	\$53,057.00		\$42,445.00	\$10,612.00		\$42,445.00	\$10,612.00
Localizer Access Road (Construction)	176	\$31,146.00		\$31,146.00	\$0.00		\$31,146.00	\$0.00
Stormwater Pollution Prevention Plan Update	105	\$8,163.20		\$6,530.00	\$1,633.20		\$6,530.00	\$1,633.20
Terminal Parking Lot Expansion (Design)	118	\$53,556.00		\$42,844.00	\$10,712.00		\$0.00	\$53,556.00
TOTALS		\$145,922.20	\$0.00	\$122,965.00	\$22,957.20	\$0.00	\$80,121.00	\$65,801.20

Remarks: Box Hangar Site Preparation (Design)

Staff recommends approval.

Localizer Access Road (Construction)

Staff recommends approval.

Stormwater Pollution Prevention Plan Update

Staff recommends approval.

Terminal Parking Lot Expansion (Design)

Staff recommends disapproval.

The existing parking lot has 17 percent more spaces than the Airport Program Manual recommendation for the size of the terminal building. The stated demand for additional spaces appears to occur only a few times a year. With an estimated construction cost of \$600,000 staff recommends the Sponsor consider alternative overflow parking solutions.

To: Virginia Aviation Board
From: Virginia Tech-Montgomery Executive Airport
Date: June 2021

REQUEST : Executive Hangar Site Preparation Design

Description: The Virginia Tech – Montgomery Executive Airport (BCB) is requesting funds for the design of the site preparation as it relates to three executive hangars, associated apron, grading, drainage improvements. It is assumed the site will accommodate a row of three 60x60 units, however the design will investigate alternative hangar sizes.

Total cost for site design is \$53,057.00.

State Cost: The request is for 80% State participation in the site design and bid and award services that totals \$42,445

To: Virginia Aviation Board
From: Virginia Tech-Montgomery Executive Airport
Date: June, 2021
RE: Storm water Pollution Prevention Plan (SWPPP) for VPDES General Permit Renewal for the Virginia Tech-Montgomery Executive Airport

Description: The Virginia Tech – Montgomery Executive Airport (VTMEA) is revising their Storm water Pollution Prevention Plan (SWPPP) adherent to 9 VAC 25-151-10. The VPDES General permit requires that the Airport maintain an up to date SWPPP to be revised with an updated registration or after major Airport facility changes. The plan will identify the most up-to-date information regarding the pollution prevention team (PPT), facilities, potential sources of pollutants, and descriptions of measures and controls. A site compliance inspection and evaluation will occur to update mapping for outfalls and to inspect their condition. Drainage maps and other mapping contained within the plan will be updated to reflect current conditions, including new industrial areas, hangars, and runway expansion facilities.

Cost: The reimbursable DOAV expense to update the SWPPP is \$6,530.00 which is 80% and the local share is \$1,633.20. The total project cost is \$8,163.20.

To: Virginia Aviation Board
From: Virginia Tech-Montgomery Executive Airport
Date: June 2021

REQUEST : Terminal Parking Lot Design

Description: The Virginia Tech – Montgomery Executive Airport (BCB) is requesting funds for the design of a 50 space parking lot to address automobile parking demands in the terminal area.

Total cost for site design is \$53,555.56.

State Cost: The request is for 80% State participation in the site design and bid and award services that totals \$42,844.44

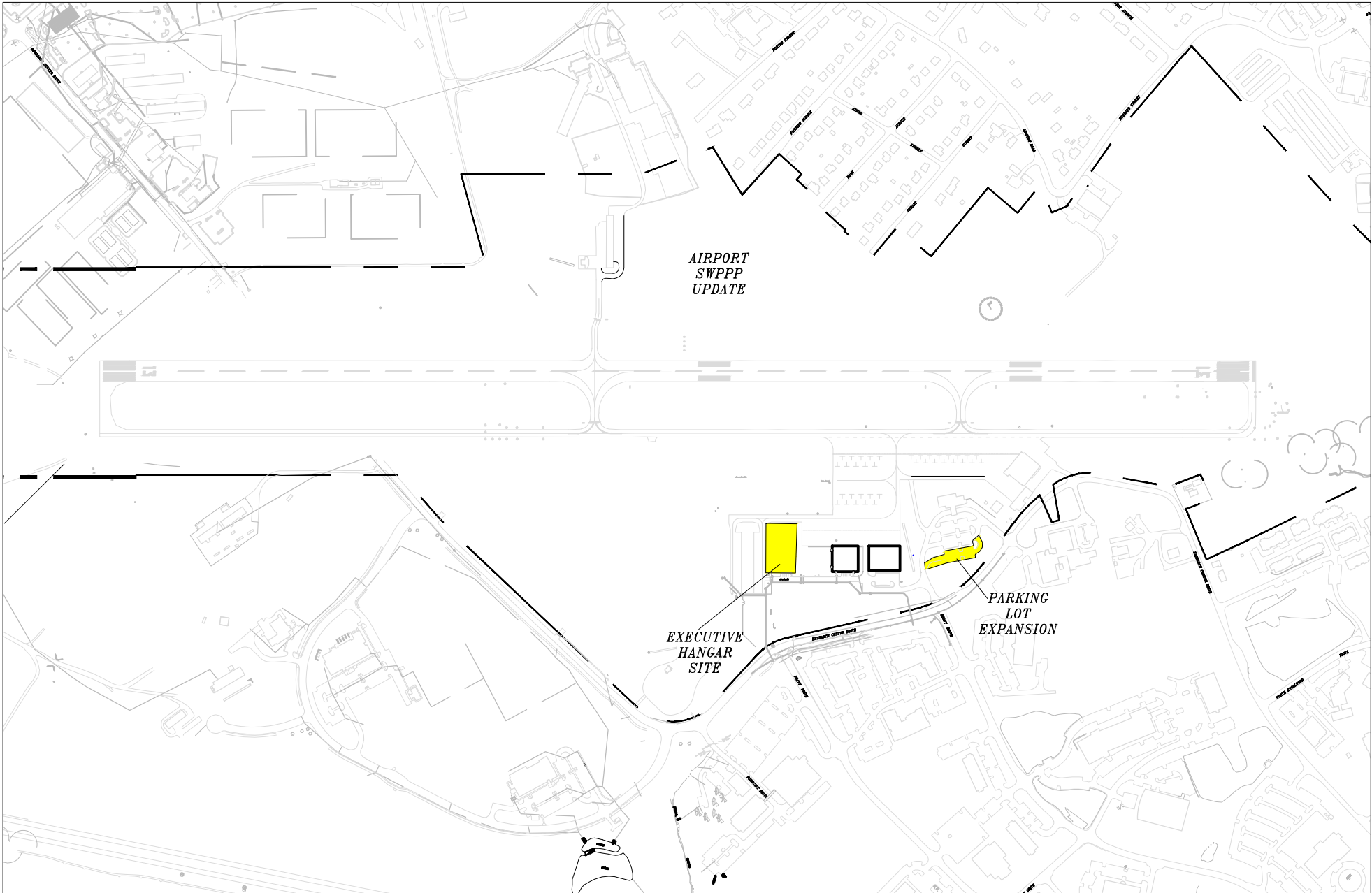

VIRGINIA TECH-MONTGOMERY EXECUTIVE AIRPORT
BLACKSBURG, VIRGINIA

JUNE VAB EXHIBIT

SCOPE OF WORK

Virginia Tech/Montgomery Executive Airport

Localizer Access Road – Construction

Funds for this project will be for the construction of a gravel localizer access road at the Virginia Tech-Montgomery Executive Airport (BCB).

The road will be 8 foot wide for a length of roughly 1,410 linear feet to provide adequate access to the localizer antenna and radio facilities for routine maintenance.

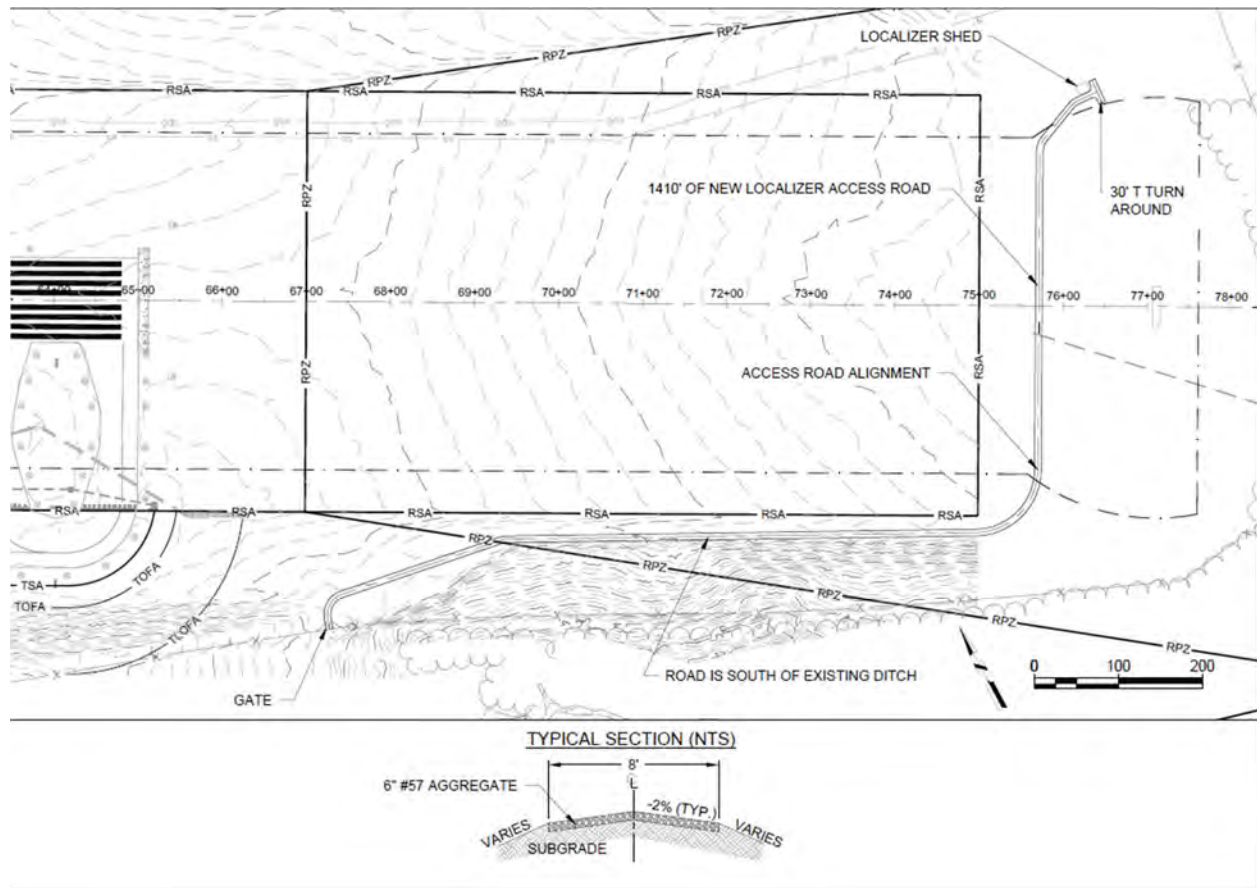

This page intentionally left blank.

Region: 2

GENERAL AVIATION AIRPORTS - DISCRETIONARY FUNDS
RECOMMENDED PROJECTS

FUNDED

PRIORITY NO.	AIRPORT NAME	DESCRIPTION	FEDERAL AMOUNT	STATE DISCR. AMOUNT	LOCAL AMOUNT	TOTAL PROJECT AMOUNT
157	Luray Caverns Airport	Rotating Beacon Replacement	\$0.00	\$7,316.00	\$1,829.00	\$9,145.00
REGION TOTALS:			\$0.00	\$7,316.00	\$1,829.00	\$9,145.00

COMMONWEALTH AVIATION FUND
 FUNDING REQUEST SUMMARY
 VAB DATE: 06/09/2021

Airport: Luray Caverns Airport
 Region: 2
 Name: Ms. Victoria Cox

Sponsor: Luray-Page County Airport Authority
 Contact: Mr. Ed Markowitz , Secretary/Treasurer
 Phone: 540-687-6301 438

State Funding Summary		
	Requested	Recommended
Entitlement	\$0.00	\$0.00
Air Carrier/Reliever Discretionary	\$0.00	\$0.00
General Aviation Discretionary	\$7,316.00	\$7,316.00
TOTALS	\$7,316.00	\$7,316.00

Unmitigated Obstructions

Based Aircraft:	25
Annual Operations:	3,526
Service Role:	GC

Development Program Projects									
Projects			Requested Funding			Recommended Funding			
Description	Priority	Project Cost	Federal	State	Local	Federal	State	Local	
Rotating Beacon Replacement	157	\$9,145.00		\$7,316.00	\$1,829.00		\$7,316.00	\$1,829.00	
TOTALS		\$9,145.00	\$0.00	\$7,316.00	\$1,829.00	\$0.00	\$7,316.00	\$1,829.00	

Remarks: Rotating Beacon Replacement
 Staff recommends approval.

Luray-Page County Airport Authority

Luray Caverns Airport

Narrative

Rotating Beacon Replacement

The existing rotating beacon at the airport became inoperable on March 2021. The existing beacon has a burned-up slip ring contactor and brushes as well as other problems. The vendor Austin Electric inspected the beacon and recommended replacement of the inoperable beacon with a Medium Intensity LED Beacon. The authority sought another quote for a beacon it could replace using airport personnel, which would save over \$6,000 on the project. The Hali-Brite beacon was chosen for the replacement in the same location.



Airport LED Rotating Beacon L-801A(L)

[Download Specification Sheet](#)

[Download Product Manual](#)

[Description](#)

Compliance with Standards:

FAA: L-801 A/C150/5345-12 (Current Edition)

ICAO: Annex 14, para 5.3.3

Applications

L-801 Rotating Beacons are designed primarily for night operation as identification and location markers for airports.

Features

- 65% power reduction over traditional metal halide lamps
- Instant on- no more waiting for bulbs to get to full bright!
- Less light pollution! Defined light beam provides less light “wash” on neighborhoods and in the sky
- Patented belt-drive system eliminates the lubrication required by conventional gear-drive beacons (U.S. Pat. 5,339,224)
- Patented liquid-filled lamp connector, eliminating the slip rings and brushes found on conventional beacons (U.S. Pat. 5,816,678)
- 50,000 hour typical lamp life (12 years)
- One white LED lamp, one aviation green LED lamp
- All moving parts are permanently lubricated
- Impedance-protected motor eliminates burnouts
- Lamps preset 5° above horizontal, adjustable
- 12 RPM rotation, 24 flashes/minute
- Weatherproof steel cabinet, powder coated international orange
- Optional stainless steel cabinet & bearings for highly corrosive environments
- Class I temperature range: -30 to +55 °C (-22 to +131 °F)
- Class II temperature range: -55 to +55 °C (-67 to +131 °F)
- Tested to wind velocities of 100 mph
- Optional photocell and/or tell-tale relay
- Mountable on a Hali-Brite [Tipdown Pole](#)
- Power Consumption L801A(L)
 - Class I; 136
 - Class II; 536W
- Manufactured in the USA

Worldwide shipping available!

GENERAL AVIATION AIRPORTS - DISCRETIONARY FUNDS
RECOMMENDED PROJECTS

FUNDED

PRIORITY NO.	AIRPORT NAME	DESCRIPTION	FEDERAL AMOUNT	STATE DISCR. AMOUNT	LOCAL AMOUNT	TOTAL PROJECT AMOUNT
197	Manassas Regional Airport	T-Hangar Taxiway Rehabilitation (Construction)	\$0.00	\$76,763.00	\$19,191.00	\$95,954.00
194	Manassas Regional Airport	Terminal Building Boiler Replacement	\$0.00	\$38,642.00	\$16,958.00	\$55,600.00
175	Leesburg Executive Airport	Hangar Site Preparation (Construction) (non-AIP)	\$0.00	\$204,800.00	\$51,200.00	\$256,000.00

Region: 3

GENERAL AVIATION AIRPORTS - DISCRETIONARY FUNDS
NOT RECOMMENDED PROJECTS

Not Recommended

PRIORITY NO.	AIRPORT NAME	DESCRIPTION	FEDERAL AMOUNT	STATE DISCR. AMOUNT	LOCAL AMOUNT	TOTAL PROJECT AMOUNT
164	Culpeper Regional Airport	Greenhouse Road Extension - Phase 1 (Construction)	\$0.00	\$0.00	\$1,936,652.00	\$1,936,652.00
REGION TOTALS:			\$0.00	\$320,205.00	\$2,024,001.00	\$2,344,206.00

COMMONWEALTH AVIATION FUND
 FUNDING REQUEST SUMMARY
 VAB DATE: 06/17/2021

Airport: Culpeper Regional Airport
 Region: 3
 Name: Mr. Derek "Dak" Hardwick

Sponsor: County of Culpeper
 Contact: Mr. John Egertson , County Administrator
 Phone: 540-727-3404

State Funding Summary		
	Requested	Recommended
Entitlement	\$0.00	\$0.00
Air Carrier/Reliever Discretionary	\$0.00	\$0.00
General Aviation Discretionary	\$1,549,321.00	\$0.00
TOTALS	\$1,549,321.00	\$0.00

Unmitigated Obstructions

Based Aircraft:	174
Annual Operations:	60,542
Service Role:	GR

Development Program Projects									
Description	Priority	Project Cost	Federal	Requested Funding			Recommended Funding		
				State	Local	Federal	State	Local	
Greenhouse Road Extension - Phase 1 (Construction)	164	\$1,936,652.00		\$1,549,321.00	\$387,331.00		\$0.00	\$1,936,652.00	
TOTALS		\$1,936,652.00	\$0.00	\$1,549,321.00	\$387,331.00	\$0.00	\$0.00	\$1,936,652.00	

Remarks: Greenhouse Road Extension - Phase 1 (Construction)

Staff recommends disapproval.

The requested project accomplishes only part of the road relocation. There will likely be cost savings by constructing Phase 1 when the FAA plans to fund Phase 2 in FY2024. In addition, Phase 1 is not required at this time for airport access as apron and hangar development is not scheduled for construction until FY2027.

Culpeper Regional Airport
Greenhouse Road Extension – Phase 1 (Construction)
Narrative

The *Greenhouse Road Extension – (Construction)* is necessary for the development of Culpeper Regional Airport in accordance with the approved master plan. The west side of the airport is almost completely developed. This road extension will provide vehicle access to the east side of the airport for development, hangar space, apron areas, and potential aviation related businesses. Additionally, the road extension represents the “relocation” of Beverly Ford Road because it will assume the Beverly Ford Road role of maintaining south-north automobile connectivity past airport property. Further, the *Greenhouse Road Extension* project will ultimately eliminate the Part 77 airspace conflict created by the current alignment of Beverly Ford Road.

This scope of work is for phase 1 of the *Greenhouse Road Extension (Construction)* project. Phase 1 is for the first ± 2,900 feet of the road from Greenhouse Road proceeding north. Phase 1 will provide access to the east side of the Culpeper Regional Airport for development and will enable future completion of phase 2. Phase 2 will eliminate the Part 77 airspace conflict created by the current alignment of Beverly Ford Road.

The scope of work provides for the construction of the *Greenhouse Road Extension – Phase 1* project, including construction phase services, nutrient credits, and stream mitigation credits.

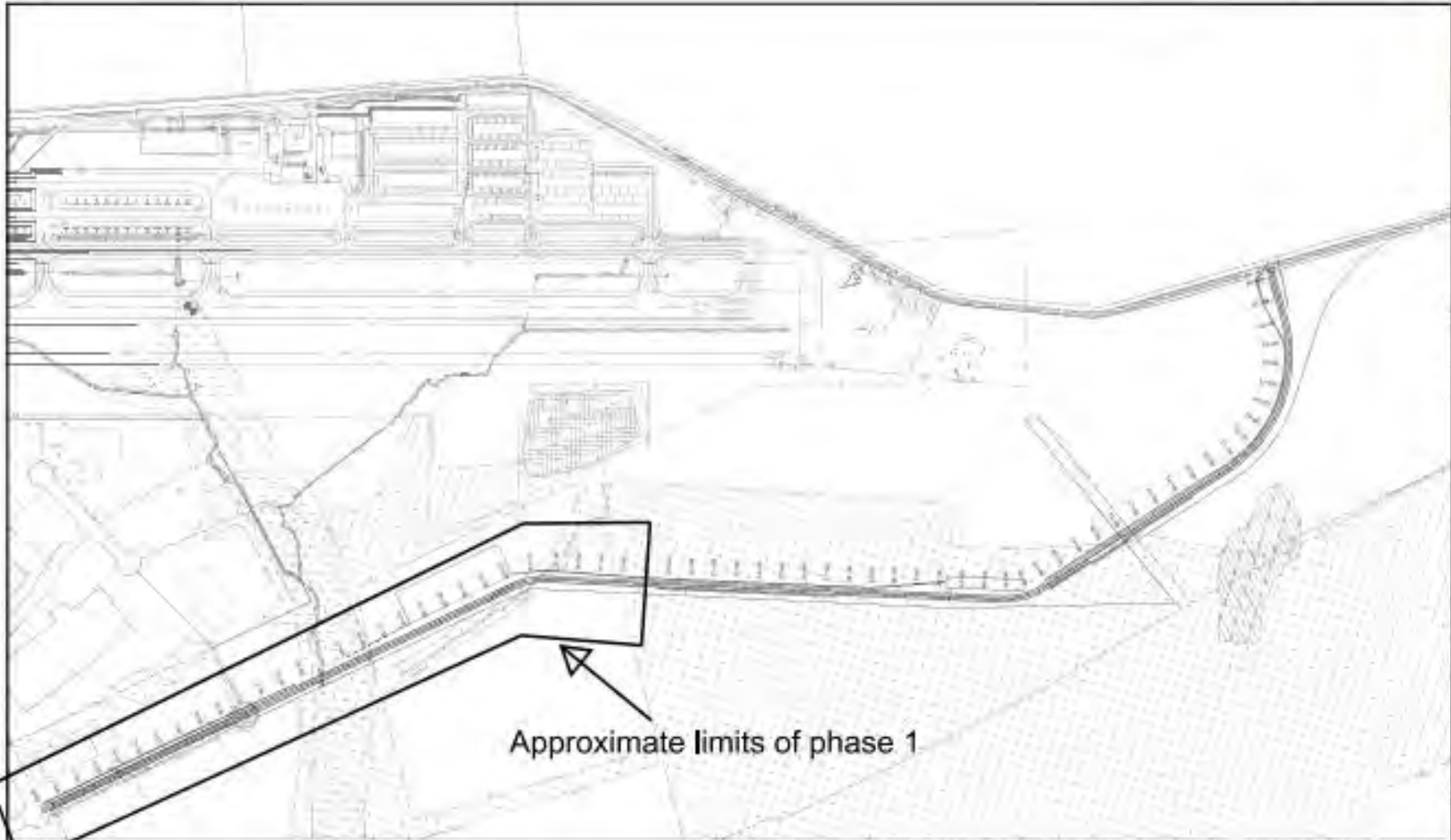

Approximate limits of phase 1

PHASE	SECTORS	ESTIMATED DURATION (MONTHS/DAYS)	ESTIMATED BIDDING PERIOD (MONTHS/DAYS)	DESCRIPTION
PHASE 1	1-06-21-21-06	6	3-00	<p>DEMOLITION OF EXISTING BUILDING AND SITE WORK AND RECONSTRUCTION OF BUILDING AND SITE WORK.</p> <p>DEMOLITION OF EXISTING BUILDING AND SITE WORK AND RECONSTRUCTION OF BUILDING AND SITE WORK.</p> <p>DEMOLITION OF EXISTING BUILDING AND SITE WORK AND RECONSTRUCTION OF BUILDING AND SITE WORK.</p>
PHASE 2	21-06-21-06	6	3-00	<p>DEMOLITION OF EXISTING BUILDING AND SITE WORK AND RECONSTRUCTION OF BUILDING AND SITE WORK.</p> <p>DEMOLITION OF EXISTING BUILDING AND SITE WORK AND RECONSTRUCTION OF BUILDING AND SITE WORK.</p> <p>DEMOLITION OF EXISTING BUILDING AND SITE WORK AND RECONSTRUCTION OF BUILDING AND SITE WORK.</p>

- NOTES:
1. CONTRACTOR SHALL BE RESPONSIBLE FOR OBTAINING ALL NECESSARY PERMITS AND APPROVALS FROM THE CITY OF CHARLOTTE.
 2. CONTRACTOR SHALL BE RESPONSIBLE FOR OBTAINING ALL NECESSARY PERMITS AND APPROVALS FROM THE CITY OF CHARLOTTE.



CARROLL & PARTNERS
 400 EAST WILSON AVENUE, SUITE 100
 CHARLOTTE, NC 28202
 PROJECT NO. 2021-001
 SHEET NO. 101

DESIGNER: CARROLL & PARTNERS
 CHECKED BY: [Signature]
 DATE: 06/17/2021

COUNTY OF MECKLENBURG
 PROJECT NO. 2021-001
 SHEET NO. 101

SCALE: 1" = 50'-0"

COMMONWEALTH AVIATION FUND
 FUNDING REQUEST SUMMARY
 VAB DATE: 06/09/2021

Airport: Leesburg Executive Airport
 Region: 3
 Name: Mr. Derek "Dak" Hardwick

Sponsor: Town of Leesburg
 Contact: Mr. Kaj Dentler , Deputy Town Manager
 Phone: 703-771-2710

State Funding Summary		
	Requested	Recommended
Entitlement	\$0.00	\$0.00
Air Carrier/Reliever Discretionary	\$204,800.00	\$0.00
General Aviation Discretionary	\$0.00	\$204,800.00
TOTALS	\$204,800.00	\$204,800.00

Unmitigated Obstructions

Based Aircraft:	225
Annual Operations:	106,024
Service Role:	RL

Development Program Projects								
Description	Priority	Project Cost	Requested Funding			Recommended Funding		
			Federal	State	Local	Federal	State	Local
Hangar Site Preparation (Construction) (non-AIP)	175	\$256,000.00		\$204,800.00	\$51,200.00		\$204,800.00	\$51,200.00
TOTALS		\$256,000.00	\$0.00	\$204,800.00	\$51,200.00	\$0.00	\$204,800.00	\$51,200.00

Remarks: Hangar Site Preparation (Construction) (non-AIP)
 Staff recommends approval.

**AIRPORT CAPITAL IMPROVEMENT PROGRAM
PROJECT NARRATIVE
LEESBURG EXECUTIVE AIRPORT (JYO)**

The following program narrative addresses the project description and justification for the current year of the Airport Capital Improvement Program.

1 North End Development - Construction (Non-AIP)

The Airport has experienced increased demand for hangar storage and also needs to provide replacement hangars for ones that will be removed in 2022 to make way for the relocated taxiway. The north end of the airfield is one of the few remaining clear areas open for development on the east side of the field. The final project will include the construction of a 26 unit T-Hangar and corporate box hangars and associated taxilanes, aprons, and auto parking facilities. This portion of the project is for the Non-AIP eligible portion of the construction.

The project budget includes a Sponsor Administrative Costs allowance for incidental costs that may be incurred.

Estimated Cost:	State (80%):	\$264,000.00
	Local (2%):	\$66,000.00

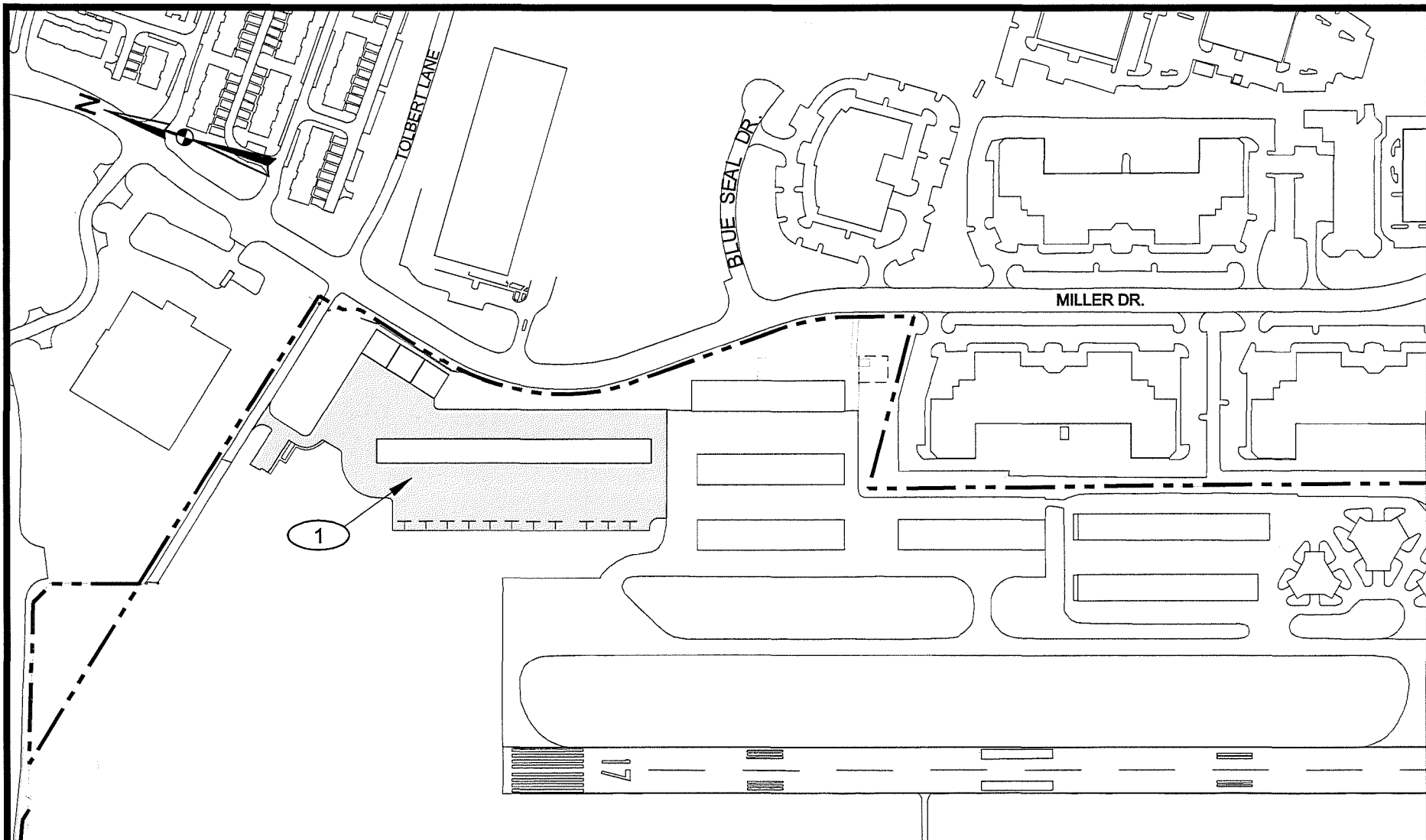

1 NORTH END DEVELOPMENT - CONSTRUCTION (NON-AIP)

ACIP SKETCH
LEESBURG EXECUTIVE AIRPORT
TALBERT & BRIGHT ENGINEERING & PLANNING CONSULTANTS 10105 KRAUSE ROAD, SUITE 100 CHESTERFIELD, VIRGINIA 23832 PHONE: 804-768-6878 FAX: 804-768-6871

COMMONWEALTH AVIATION FUND
 FUNDING REQUEST SUMMARY
 VAB DATE: 06/17/2021

Airport: Manassas Regional Airport
 Region: 3
 Name: Mr. Derek "Dak" Hardwick

Sponsor: City of Manassas
 Contact: Mr. Juan Rivera , Director
 Phone: 703-257-8261

State Funding Summary		
	Requested	Recommended
Entitlement	\$0.00	\$0.00
Air Carrier/Reliever Discretionary	\$0.00	\$0.00
General Aviation Discretionary	\$115,405.00	\$115,405.00
TOTALS	\$115,405.00	\$115,405.00

Unmitigated Obstructions

Based Aircraft:	391
Annual Operations:	87,607
Service Role:	RL

Development Program Projects								
Description	Priority	Project Cost	Requested Funding			Recommended Funding		
			Federal	State	Local	Federal	State	Local
Terminal Building Boiler Replacement	194	\$55,600.00		\$38,642.00	\$16,958.00		\$38,642.00	\$16,958.00
T-Hangar Taxiway Rehabilitation (Construction)	197	\$95,954.00		\$76,763.00	\$19,191.00		\$76,763.00	\$19,191.00
TOTALS		\$151,554.00	\$0.00	\$115,405.00	\$36,149.00	\$0.00	\$115,405.00	\$36,149.00

Remarks: Terminal Building Boiler Replacement
 Staff recommends approval.

T-Hangar Taxiway Rehabilitation (Construction)
 Staff recommends approval.

Manassas Regional Airport

June VAB Project Narratives

Repave East City T-Hangars:

Repave and rehabilitate pavement at East T-Hangars. The pavement is more than 20 years old and is in need of repair. The condition of the subgrade is unknown and drainage is less than adequate. This project is supported by the Airport's pavement management program. This project would restore drainage and repair pavement conditions between the hangar alleyways. The project requested in June is proposed to complete paving on the first three rows of the hangars.



Terminal Building Boiler Replacement:

The boiler system for the terminal building has reached the end of its useful life. The boiler provides heat for the entire terminal building. This project would provide for the installation of a new boiler for the terminal building. Details of the new system are provided in the accompanying proposal.

Springfield
7921 Woodruff Court
Springfield, VA 22151

Richmond
116 Sylvia Drive, Suite F
Ashland, VA 23005



Baltimore
1730 Twin Springs Road #217
Baltimore, MD 21227

Eastern Shore
805 N. Salisbury Blvd., # 3200
Salisbury, MD 21801

March 16, 2021

Proposal #L21-0068

Manassas Regional Airport
10600 Harry Parrish Blvd.
Manassas, Virginia 20110

Jobsite:
Boiler Room

Attn: Doug McCauley
Email: Dmccauley@manassasva.com
Phone: 571-233-1773

Page 1 of 2

RE: Replace Weil McLain Boiler with a New AERCO Condensing Boiler

Proposal-Acceptance

We hereby submit the Scope of Work requested with estimates for supplying the necessary labor and material to complete the following:

1. Demo Old Style Weil McLain 78 Series boiler.
2. Supply and install new Qty (1) Model: AM 1000B Advanced Modular 1000 MBH Boiler which will include the following:
 - a. 58133-5 Inlet Gas Pressure 1 Supply Pressure Natural Gas Supply Pressure
 - b. Instruction Package: INSTRUCTION PACKAGE (O&M)
 - c. 58142-03 AM1000B RELIEF VALVE KIT
 - d. 99251-4 - VAR SPD PUMP GRUNDFOS MAGNA 65-150 KIT
 - e. 69254-3 High Vent Temperature Kit
 - f. Natural Gas
 - g. Electrical: 120/1/60
 - h. EXHAUST VENTING Duravent PolyPro 6" diameter. 20' with roof flashing and storm collar, T termination
 - i. CSD-1 Complaint
3. Pipe in new boiler to the system.
4. Pipe in new burner to the existing gas service.
5. Install new Polyurethane Stack using the existing stack for a sleeve to vent above the roof.
6. Wire new boiler.
7. Insulate new piping.
8. Startup and check out operation.

We hereby propose to furnish material and labor complete in accordance with the above proposed scope of work for the sum of:

Sixty-Six Thousand Nine Hundred Seventy-Six Dollars

\$66,976.00



All materials guaranteed to be as specified. All work to be completed in a professional manner per standard practices. Any alteration or deviation from above specifications involving extra costs will be executed only upon written change orders and will become an extra charge over and above the estimate. A service charge of 1 1/2% per month will be charged on any unpaid balance after 30 days. In the event the account is sent for collection, client agrees to pay all costs and expenses of collection, including all court costs and attorneys' fees paid and/or incurred by Capitol Boiler Works, Inc. in seeking to collect this bill.

**INDUSTRIAL
COMBUSTION**



This page intentionally left blank.

Region: 4

GENERAL AVIATION AIRPORTS - DISCRETIONARY FUNDS
RECOMMENDED PROJECTS

FUNDED

PRIORITY NO.	AIRPORT NAME	DESCRIPTION	FEDERAL AMOUNT	STATE DISCR. AMOUNT	LOCAL AMOUNT	TOTAL PROJECT AMOUNT
183	Hanover County Municipal Airport	Terminal Building Furniture	\$0.00	\$41,126.00	\$10,282.00	\$51,408.00

Region: 4

GENERAL AVIATION AIRPORTS - DISCRETIONARY FUNDS
NOT RECOMMENDED PROJECTS

Not Recommended

PRIORITY NO.	AIRPORT NAME	DESCRIPTION	FEDERAL AMOUNT	STATE DISCR. AMOUNT	LOCAL AMOUNT	TOTAL PROJECT AMOUNT
125	Richmond Executive - Chesterfield County Airport	Southeast Apron Expansion (Design)	\$0.00	\$0.00	\$210,600.00	\$210,600.00
125	Richmond Executive - Chesterfield County Airport	Southeast Box Hangars Site Preparation (Design)	\$0.00	\$0.00	\$195,800.00	\$195,800.00
REGION TOTALS:			\$0.00	\$41,126.00	\$416,682.00	\$457,808.00

COMMONWEALTH AVIATION FUND
 FUNDING REQUEST SUMMARY
 VAB DATE: 06/09/2021

Airport: Hanover County Municipal Airport
 Region: 4
 Name: Mr. Alan Abbott

Sponsor: County of Hanover
 Contact: Mr. Mike Flagg , Director of Public Works
 Phone: 840-365-6182

State Funding Summary		
	Requested	Recommended
Entitlement	\$0.00	\$0.00
Air Carrier/Reliever Discretionary	\$41,126.00	\$0.00
General Aviation Discretionary	\$0.00	\$41,126.00
TOTALS	\$41,126.00	\$41,126.00

Unmitigated Obstructions

Based Aircraft:	100
Annual Operations:	37,287
Service Role:	RL

Development Program Projects									
Description	Priority	Project Cost	Federal	Requested Funding			Recommended Funding		
				State	Local	Federal	State	Local	
Terminal Building Furniture	183	\$51,408.00		\$41,126.00	\$10,282.00		\$41,126.00	\$10,282.00	
TOTALS		\$51,408.00	\$0.00	\$41,126.00	\$10,282.00	\$0.00	\$41,126.00	\$10,282.00	

Remarks: Terminal Building Furniture
 Staff recommends approval.

NARRATIVE
TERMINAL BUILDING FURNITURE
HANOVER COUNTY MUNICIPAL AIRPORT

Hanover County dedicated the existing public terminal building on May 30, 1971. This terminal on the West Side of Runway 16 -34, no longer has the capacity to accommodate the increased air traffic and passenger flow. A new Terminal Building on the East Side of the Runway is currently under construction and is set to be completed between October and December 2021, **fifty years** after the original terminal opened. Funding was never requested for the existing terminal building furniture. A physical count of the daily flight operations taken on May 6, 2021 totaled 152 operations, if this is an example of an average day, the yearly operations will exceed 55,000.

Given delays being experienced due COVID, in order to have furniture delivered in time for the terminal opening, we are requesting grant funding be approved by the Virginia Aviation Board at the June 2021 Meeting. Requests for quotes on the furniture have been given to two State contractors and the cost is expected to come in around \$75,000

The new terminal building will have roughly 6,500 square feet of floor space with 5,712 square feet of dedicated and combined (joint use) public use space. Using the Airport Program guidelines for available funding (see attached plan sheet), the maximum project amount to receive 80% funding would be **\$51,408.00** with the State funding request being **\$41,126.40**.

Hanover County will fund the local 20% share of **\$10,281.60** along with 100% of the overage (currently anticipated to be **\$23,592.00**).

The attached Narrative Sketch provides the planned furniture locations in each of the Public Use space areas and the furniture is tallied on the plan sheet. All furniture will be made of durable fabrics and coverings of the type typically used in higher traffic public areas.

TOTAL AMOUNT OF FUNDING REQUESTED: \$41,126.40

Hanover County Municipal Terminal Furniture Narrative Sketch

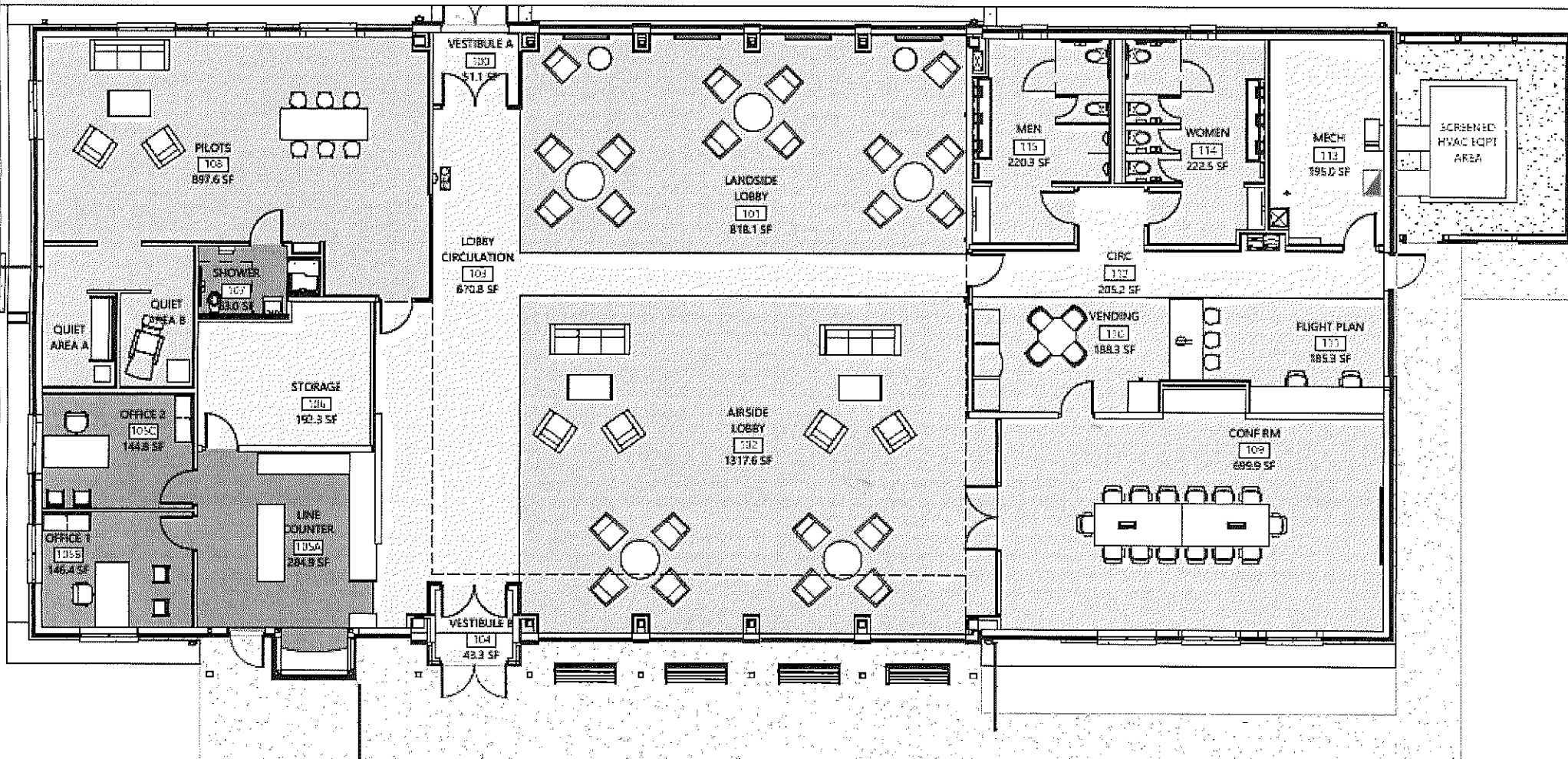

COMMONWEALTH AVIATION FUND
 FUNDING REQUEST SUMMARY
 VAB DATE: 06/17/2021

Airport: Richmond Executive - Chesterfield County Airport
 Region: 4
 Name: Mr. Alan Abbott

Sponsor: County of Chesterfield
 Contact: Mr. Jeremy Wilkinson , Acting Airport Manager
 Phone: 804-768-7700

State Funding Summary		
	Requested	Recommended
Entitlement	\$0.00	\$0.00
Air Carrier/Reliever Discretionary	\$300,645.00	\$0.00
General Aviation Discretionary	\$0.00	\$0.00
TOTALS	\$300,645.00	\$0.00

Unmitigated Obstructions

Based Aircraft:	119
Annual Operations:	67,623
Service Role:	RL

Development Program Projects								
Description	Priority	Project Cost	Requested Funding			Recommended Funding		
			Federal	State	Local	Federal	State	Local
Southeast Apron Expansion (Design)	125	\$210,600.00		\$168,480.00	\$42,120.00		\$0.00	\$210,600.00
Southeast Box Hangars Site Preparation (Design)	125	\$195,800.00		\$132,165.00	\$63,635.00		\$0.00	\$195,800.00
TOTALS		\$406,400.00	\$0.00	\$300,645.00	\$105,755.00	\$0.00	\$0.00	\$406,400.00

Remarks: Southeast Apron Expansion (Design)

Staff recommends disapproval.

The immediate use of the apron remains in question. In addition, the planned width of the apron does not appear sufficient for the transient DoD aircraft currently using the airport for refueling. Staff is still researching whether the apron will have a proprietary use so further study is required.

Southeast Box Hangars Site Preparation (Design)

Staff recommends disapproval.

The immediate use of the hangar site remains in question. Staff is still researching whether the hangar site will have a proprietary use so further study is required.

PROJECT NARRATIVE

SUBMITTED FOR JUNE 2021 VIRGINIA AVIATION BOARD MEETING

RICHMOND EXECUTIVE – CHESTERFIELD COUNTY AIRPORT

1. SE Apron – Apron (Design)

The proposed project at the Richmond Executive – Chesterfield County Airport includes design of a new apron to accommodate current and future operational and tenant demand and enhance customer service. All corporate hangar locations at the airport are currently leased and are fully occupied.

The apron design includes the following:

- Taxiway connector from Taxiway A to the associated hangar apron space
- Aircraft apron for two hangars
- Stormwater management

Environmental review for the proposed work was recently completed in close coordination with the DOAV and FAA, with a Finding of No Significant Impact (FONSI) issued in January 2021.

Proposed Funding: DOAV 80%, Local 20%

2. SE Apron – Hangar Site Preparation (Design)

The proposed project at the Richmond Executive – Chesterfield County Airport includes design of hangar site for two corporate hangars. All corporate hangar locations at the airport are currently leased and are fully occupied.

The hangar site preparation design includes the following:

- Access road from Airfield Drive
- Automobile parking area for two hangars
- Utility design
- Site prep for two clear span hangars
- Stormwater management

Environmental review for the proposed work was recently completed in close coordination with the DOAV and FAA, with a Finding of No Significant Impact (FONSI) issued in January 2021.

Proposed Funding: DOAV 67.5%, Local 32.5%

END OF PROJECT NARRATIVE

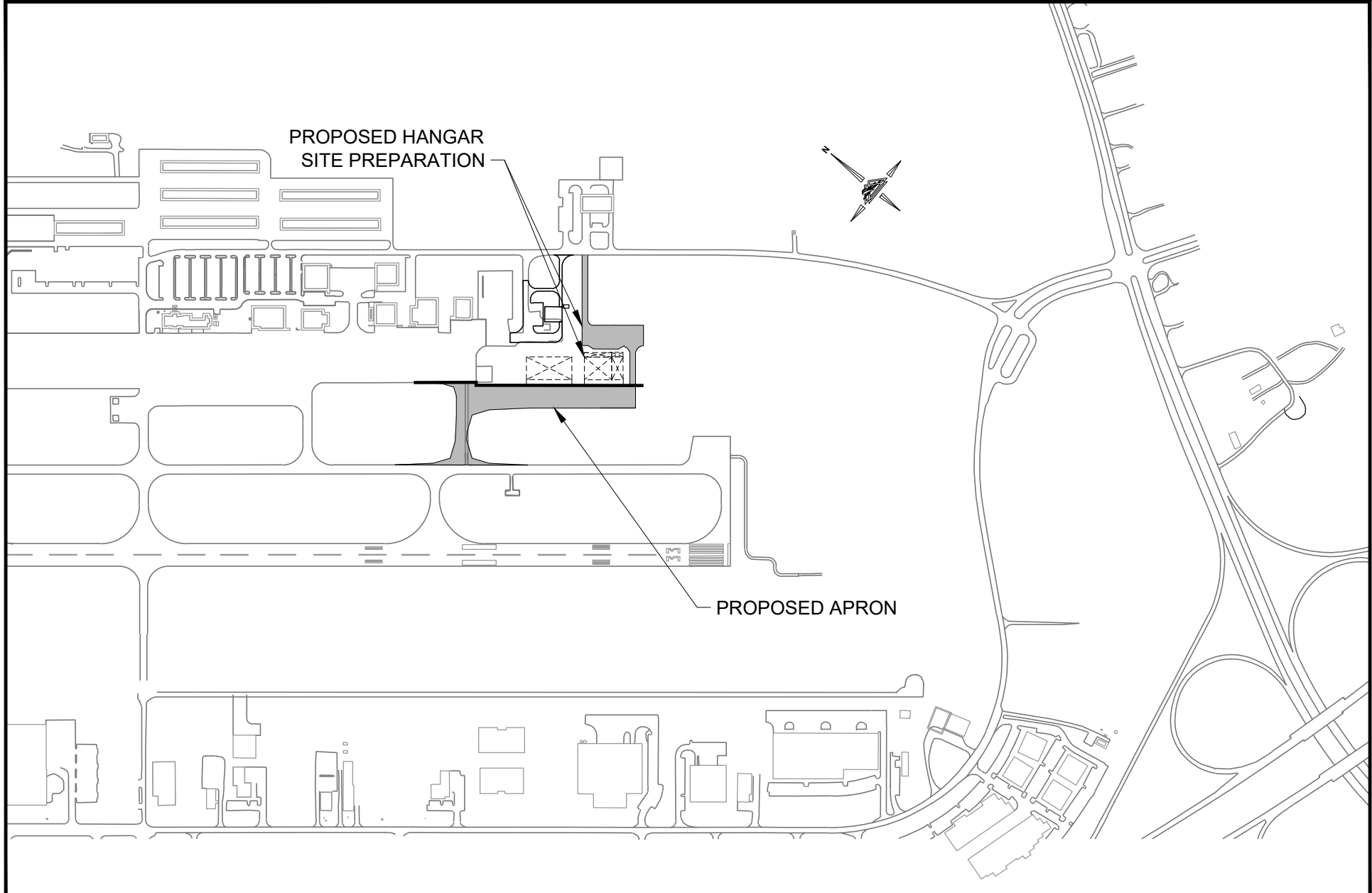

 www.deltaairport.com	SOUTHEAST APRON DEVELOPMENT SKETCH VAB 2021-06 RICHMOND EXECUTIVE - CHESTERFIELD COUNTY AIRPORT					EXHIBIT 1
	DRAWN BY: NLM	CHECKED BY: TSE	SCALE: 1"=600'	DATE: APRIL 2021		

GENERAL AVIATION AIRPORTS - DISCRETIONARY FUNDS
RECOMMENDED PROJECTS

FUNDED

PRIORITY NO.	AIRPORT NAME	DESCRIPTION	FEDERAL AMOUNT	STATE DISCR. AMOUNT	LOCAL AMOUNT	TOTAL PROJECT AMOUNT
100	Danville Regional Airport	Box Hangar Site Preparation (Design)	\$0.00	\$71,116.00	\$17,779.00	\$88,895.00
86	Allen C. Perkinson Municipal Airport	Apron Rehabilitation (Design)	\$0.00	\$40,000.00	\$10,000.00	\$50,000.00
REGION TOTALS:			\$0.00	\$111,116.00	\$27,779.00	\$138,895.00

COMMONWEALTH AVIATION FUND
 FUNDING REQUEST SUMMARY
 VAB DATE: 06/09/2021

Airport: Allen C. Perkinson Municipal Airport
 Region: 5
 Name: Ms. Maggie Ragon

Sponsor: Town of Blackstone
 Contact: Mr. Phillip Vannoorbeeck , Town Manager
 Phone: 434-292-7251

State Funding Summary		
	Requested	Recommended
Entitlement	\$0.00	\$0.00
Air Carrier/Reliever Discretionary	\$0.00	\$0.00
General Aviation Discretionary	\$40,000.00	\$40,000.00
TOTALS	\$40,000.00	\$40,000.00

Unmitigated Obstructions

Based Aircraft:	8
Annual Operations:	1,286
Service Role:	GC

Development Program Projects									
Projects			Requested Funding			Recommended Funding			
Description	Priority	Project Cost	Federal	State	Local	Federal	State	Local	
Apron Rehabilitation (Design)	86	\$50,000.00		\$40,000.00	\$10,000.00		\$40,000.00	\$10,000.00	
TOTALS		\$50,000.00	\$0.00	\$40,000.00	\$10,000.00	\$0.00	\$40,000.00	\$10,000.00	

Remarks: Apron Rehabilitation (Design)
 Staff recommends approval.

**AIRPORT CAPITAL IMPROVEMENT PROGRAM
PROJECT NARRATIVE
BLACKSTONE / ALLEN C. PERKINSON MUNICIPAL AIRPORT (BKT)**

The following program narrative addresses the project description and justification for the current year of the Airport Capital Improvement Program.

1 - Terminal Apron Rehabilitation (Design)

This project includes the rehabilitation of the existing terminal apron (approx. 30,000 sf) and existing connector taxiway. The existing pavements are showing signs of distress. The pavement is badly oxidized and becoming brittle. It has been cracked sealed numerous times and is in need of rehabilitation to avoid full reconstruction. As part of this project additional tie downs will be installed, the new pavement will be seal coated and new markings for the apron and taxiway pavements.

The project budget includes an allowance for Sponsor Administrative Costs that may be needed.

Estimated Cost:	DOAV (80%):	\$40,000.00
	BKT (20%):	\$10,000.00

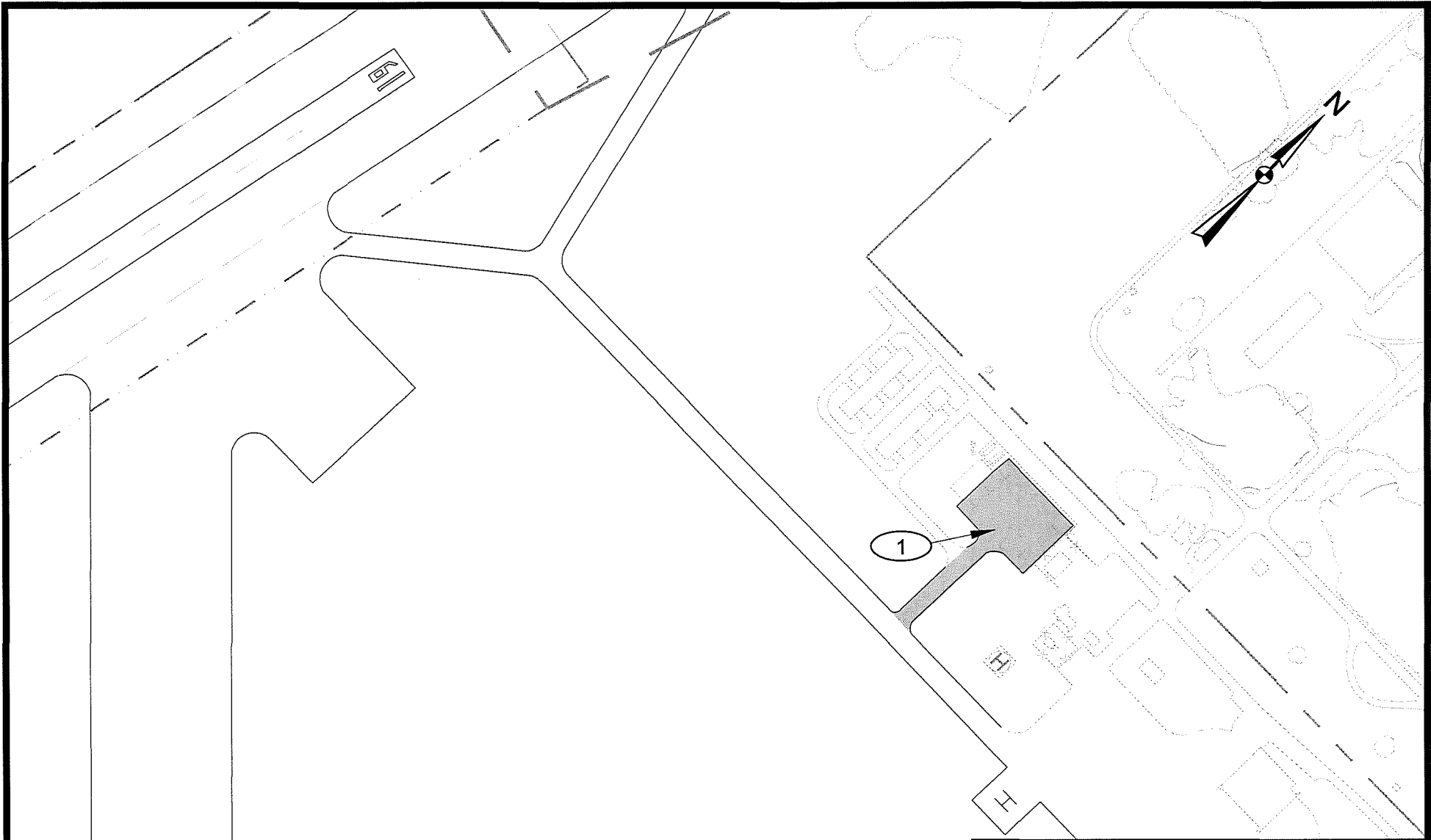

① TERMINAL APRON REHABILITATION

ACIP SKETCH
BLACKSTONE MUNICIPAL AIRPORT
TALBERT & BRIGHT ENGINEERING & PLANNING CONSULTANTS 10105 KRAUSE ROAD, SUITE 100 CHESTERFIELD, VIRGINIA 23832 PHONE: 804-768-6878 FAX: 804-768-6871

COMMONWEALTH AVIATION FUND
 FUNDING REQUEST SUMMARY
 VAB DATE: 06/09/2021

Airport: Danville Regional Airport
 Region: 5
 Name: Ms. Maggie Ragon

Sponsor: City of Danville
 Contact: Mr. Marc Adelman , Director of Transportation Services
 Phone: 434-799-5110

State Funding Summary		
	Requested	Recommended
Entitlement	\$0.00	\$0.00
Air Carrier/Reliever Discretionary	\$0.00	\$0.00
General Aviation Discretionary	\$71,116.00	\$71,116.00
TOTALS	\$71,116.00	\$71,116.00

Unmitigated Obstructions

Based Aircraft:	46
Annual Operations:	19,080
Service Role:	GR

Development Program Projects									
Description	Priority	Project Cost	Federal	Requested Funding			Recommended Funding		
				State	Local	Federal	State	Local	
Box Hangar Site Preparation (Design)	100	\$88,895.00		\$71,116.00	\$17,779.00		\$71,116.00	\$17,779.00	
TOTALS		\$88,895.00	\$0.00	\$71,116.00	\$17,779.00	\$0.00	\$71,116.00	\$17,779.00	

Remarks: Box Hangar Site Preparation (Design)
 Staff recommends approval.

NARRATIVE

DANVILLE REGIONAL AIRPORT

Corporate Hangar Site Development and Parking Lot for Thirty-Nine (39) automobiles

Currently, all corporate hangars and t-hangars are occupied at the Danville Regional Airport. This project will provide site preparation for three (3) future, corporate-size public use hangars and a paved aircraft apron area in front of the future hangars. Additionally, the project will include the construction of an automobile parking lot for thirty-nine (39) vehicles. Site prep activities would support the development of corporate hangars up to 13,000 square feet per building. Prior to the completion of the corporate hangars the aircraft apron area will provide surplus aircraft parking space to support anticipated casino traffic that overlaps with major Virginia International Raceway events. Presently, when major races occur most of the existing terminal ramp area is utilized by jet and turbo-prop aircraft owners.

DANVILLE REGIONAL AIRPORT (KDAN)
DANVILLE, VIRGINIA
PROPOSED AIRPORT PROJECT

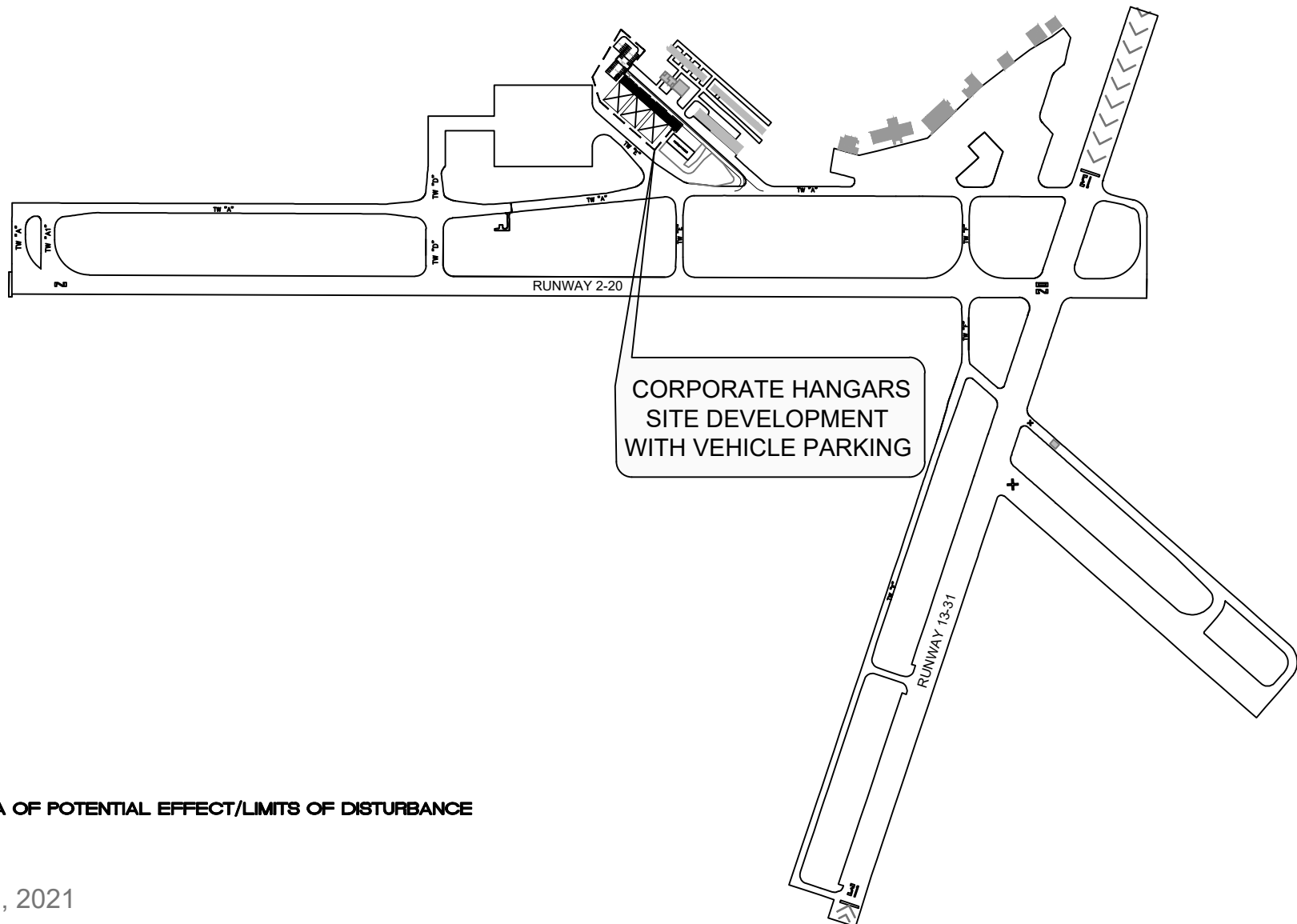

--- AREA OF POTENTIAL EFFECT/LIMITS OF DISTURBANCE

April 22, 2021

Path: I:\3004 DANVILLE REGIONAL\3004-100 Corporate Hangars Site Development\ Plan 2004-1000 Corporate Hangars Site Development.dwg Saved: Apr 22, 2021 - 10:42am by jmf / P:\hobbs Apr 22, 2021 - 10:42am

This page intentionally left blank.

GENERAL AVIATION AIRPORTS - DISCRETIONARY FUNDS
RECOMMENDED PROJECTS

FUNDED

PRIORITY NO.	AIRPORT NAME	DESCRIPTION	FEDERAL AMOUNT	STATE DISCR. AMOUNT	LOCAL AMOUNT	TOTAL PROJECT AMOUNT
142	Franklin Municipal Airport	Apron Sinkhole Repair (Construction)	\$0.00	\$11,600.00	\$2,900.00	\$14,500.00
112	Wakefield Municipal Airport	Runway Lighting Rehabilitation (Design)	\$0.00	\$40,000.00	\$10,000.00	\$50,000.00
REGION TOTALS:			\$0.00	\$51,600.00	\$12,900.00	\$64,500.00

COMMONWEALTH AVIATION FUND
 FUNDING REQUEST SUMMARY
 VAB DATE: 06/09/2021

Airport: Franklin Municipal Airport
 Region: 6
 Name: TBA

Sponsor: City of Franklin
 Contact: Ms. Amanda Jarratt , City Manager
 Phone: 757-562-8561

State Funding Summary		
	Requested	Recommended
Entitlement	\$0.00	\$0.00
Air Carrier/Reliever Discretionary	\$0.00	\$0.00
General Aviation Discretionary	\$11,600.00	\$11,600.00
TOTALS	\$11,600.00	\$11,600.00

Unmitigated Obstructions

Based Aircraft:	16
Annual Operations:	4,213
Service Role:	GC

Development Program Projects									
Description	Priority	Project Cost	Federal	Requested Funding			Recommended Funding		
				State	Local	Federal	State	Local	
Apron Sinkhole Repair (Construction)	142	\$14,500.00		\$11,600.00	\$2,900.00		\$11,600.00	\$2,900.00	
TOTALS		\$14,500.00	\$0.00	\$11,600.00	\$2,900.00	\$0.00	\$11,600.00	\$2,900.00	

Remarks: Apron Sinkhole Repair (Construction)
 Staff recommends approval.

City of Franklin

Franklin Municipal Airport

Narrative

Apron Sinkhole Repair (Construction)

This project will repair the sinkhole near the eastward corner of apron. The project will consist of the following:

- Saw cut and removal of existing concrete over a leaking/failing storm drain pipe
- Removal and replacement of existing chain link fencing as needed
- Plugging, excavating, and removing approximately 160 lf existing storm drain pipe
- Removal from site excavated soils unsuitable for backfill
- Furnishing and installing approximately 160 lf of new 15" CPP over 6" of VDOT no 57 stone
- Furnishing, installing and compacting suitable sand backfill around the pipe and 8" of 21A stone to match existing surface grades to facilitate stormwater runoff.

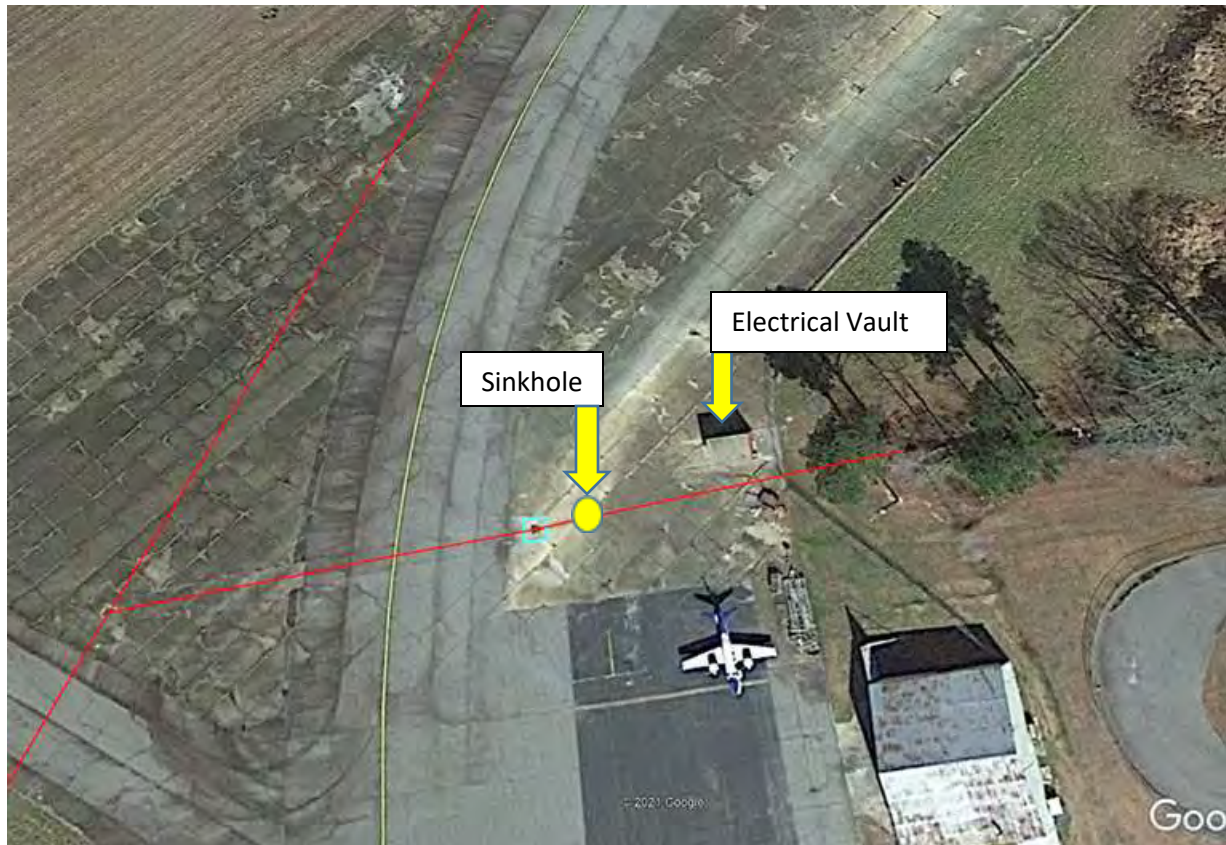

COMMONWEALTH AVIATION FUND
 FUNDING REQUEST SUMMARY
 VAB DATE: 06/09/2021

Airport: Wakefield Municipal Airport
 Region: 6
 Name: TBA

Sponsor: Town of Wakefield
 Contact: Mr. Brian Laine , Mayor
 Phone: 757-758-2629

State Funding Summary		
	Requested	Recommended
Entitlement	\$0.00	\$0.00
Air Carrier/Reliever Discretionary	\$0.00	\$0.00
General Aviation Discretionary	\$40,000.00	\$40,000.00
TOTALS	\$40,000.00	\$40,000.00

Unmitigated Obstructions

Based Aircraft:	20
Annual Operations:	16,286
Service Role:	GC

Development Program Projects									
Projects			Requested Funding			Recommended Funding			
Description	Priority	Project Cost	Federal	State	Local	Federal	State	Local	
Runway Lighting Rehabilitation (Design)	112	\$50,000.00		\$40,000.00	\$10,000.00		\$40,000.00	\$10,000.00	
TOTALS		\$50,000.00	\$0.00	\$40,000.00	\$10,000.00	\$0.00	\$40,000.00	\$10,000.00	

Remarks: Runway Lighting Rehabilitation (Design)
 Staff recommends approval.

**AIRPORT CAPITAL IMPROVEMENT PROGRAM
PROJECT NARRATIVE
WAKEFIELD MUNICIPAL AIRPORT (AKQ)**

The following project narrative addresses the project description and justification for the current year of the Airport Capital Improvement Program.

1 – Runway Lighting Rehabilitation (Construction)

The existing constant voltage medium intensity runway lighting (MIRL) system is well over 20 years old and has outlived its useful life. The cable and lighting fixtures will be replaced and the lighting power distribution panel will be upgraded as needed along with the photocell and pilot control lighting system.

The project budget includes an allowance for bid advertisement, copies, shipping and other incidental Sponsor Administrative Costs that may be incurred.

Estimated Cost:	State (80%):	\$40,000
	Local (20%):	\$10,000

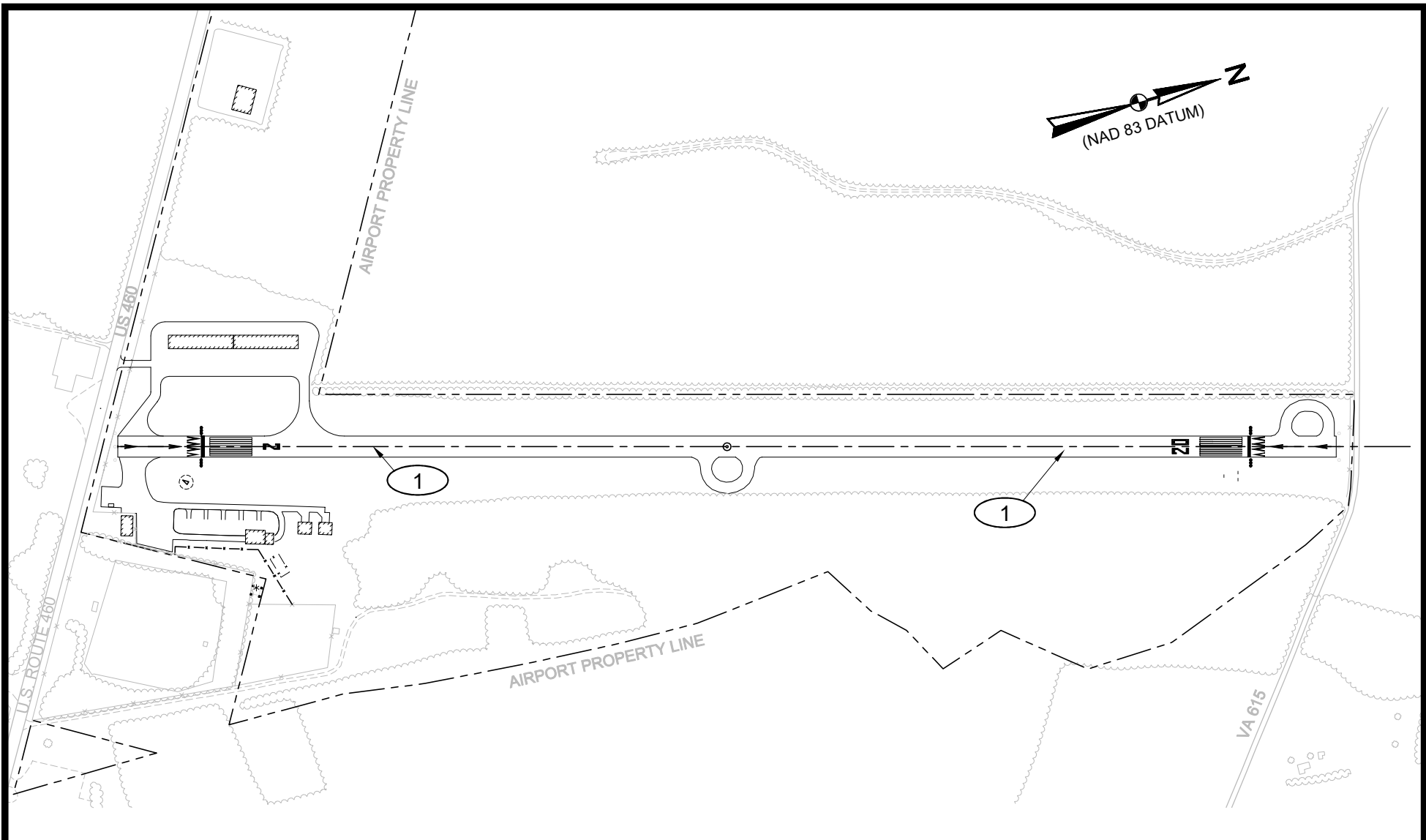

① RUNWAY LIGHTING REHABILITATION - DESIGN

ACIP SKETCH
WAKEFIELD MUNICIPAL AIRPORT
TALBERT & BRIGHT ENGINEERING & PLANNING CONSULTANTS 10105 KRAUSE ROAD, SUITE 100 CHESTERFIELD, VIRGINIA 23832 PHONE: 804-768-6878 FAX: 804-768-6871

GENERAL AVIATION AIRPORTS - DISCRETIONARY FUNDS
RECOMMENDED PROJECTS

FUNDED

PRIORITY NO.	AIRPORT NAME	DESCRIPTION	FEDERAL AMOUNT	STATE DISCR. AMOUNT	LOCAL AMOUNT	TOTAL PROJECT AMOUNT
194	Chesapeake Regional Airport	Terminal Building Restrooms Renovation	\$0.00	\$5,543.00	\$1,386.34	\$6,929.34
184	Hampton Roads Executive Airport	T-Hangar Taxilane Repair (Construction)	\$0.00	\$5,400.00	\$1,350.00	\$6,750.00
162	Middle Peninsula Regional Airport	Rotating Beacon Replacement (Construction)	\$0.00	\$12,160.00	\$3,040.00	\$15,200.00

Region: 7

GENERAL AVIATION AIRPORTS - DISCRETIONARY FUNDS
NOT RECOMMENDED PROJECTS

Not Recommended

PRIORITY NO.	AIRPORT NAME	DESCRIPTION	FEDERAL AMOUNT	STATE DISCR. AMOUNT	LOCAL AMOUNT	TOTAL PROJECT AMOUNT
165	Hampton Roads Executive Airport	Entrance Sign Replacement (Construction)	\$0.00	\$0.00	\$6,988.10	\$6,988.10
110	Middle Peninsula Regional Airport	Access Road & Box Hangar Site (Environmental)	\$0.00	\$0.00	\$24,000.00	\$24,000.00
70	Hummel Field	Environmental Impact Report	\$0.00	\$0.00	\$39,900.00	\$39,900.00
REGION TOTALS:			\$0.00	\$23,103.00	\$76,664.44	\$99,767.44

COMMONWEALTH AVIATION FUND
 FUNDING REQUEST SUMMARY
 VAB DATE: 06/09/2021

Airport: Chesapeake Regional Airport
 Region: 7
 Name: Ms. Vanessa Christie

Sponsor: Chesapeake Airport Authority
 Contact: Mr. Chris Schrantz , Manager
 Phone: 757-432-8110

State Funding Summary		
	Requested	Recommended
Entitlement	\$0.00	\$0.00
Air Carrier/Reliever Discretionary	\$5,543.00	\$0.00
General Aviation Discretionary	\$0.00	\$5,543.00
TOTALS	\$5,543.00	\$5,543.00

Unmitigated Obstructions

Based Aircraft:	121
Annual Operations:	50,967
Service Role:	RL

Development Program Projects									
Projects			Requested Funding			Recommended Funding			
Description	Priority	Project Cost	Federal	State	Local	Federal	State	Local	
Terminal Building Restrooms Renovation	194	\$6,929.34		\$5,543.00	\$1,386.34		\$5,543.00	\$1,386.34	
TOTALS		\$6,929.34	\$0.00	\$5,543.00	\$1,386.34	\$0.00	\$5,543.00	\$1,386.34	

Remarks: Terminal Building Restrooms Renovation
 Staff recommends approval.

CPK Public Restroom Rehabilitation Narrative

Chesapeake Regional Airport is planning to remove failing counter tops, sinks and plumbing, 3 toilets and one urinal. Existing fixtures have been exposed to well water and have become irrevocably stained. Counter tops have been compromised by repeated water exposure.

Chesapeake plans to replace the counter tops with impermeable material. The replacement porcelain fixtures and plumbing will be installed by airport maintenance staff using materials supplied by Ferguson.

Chesapeake Regional Airport Terminal Building

Restroom rehub

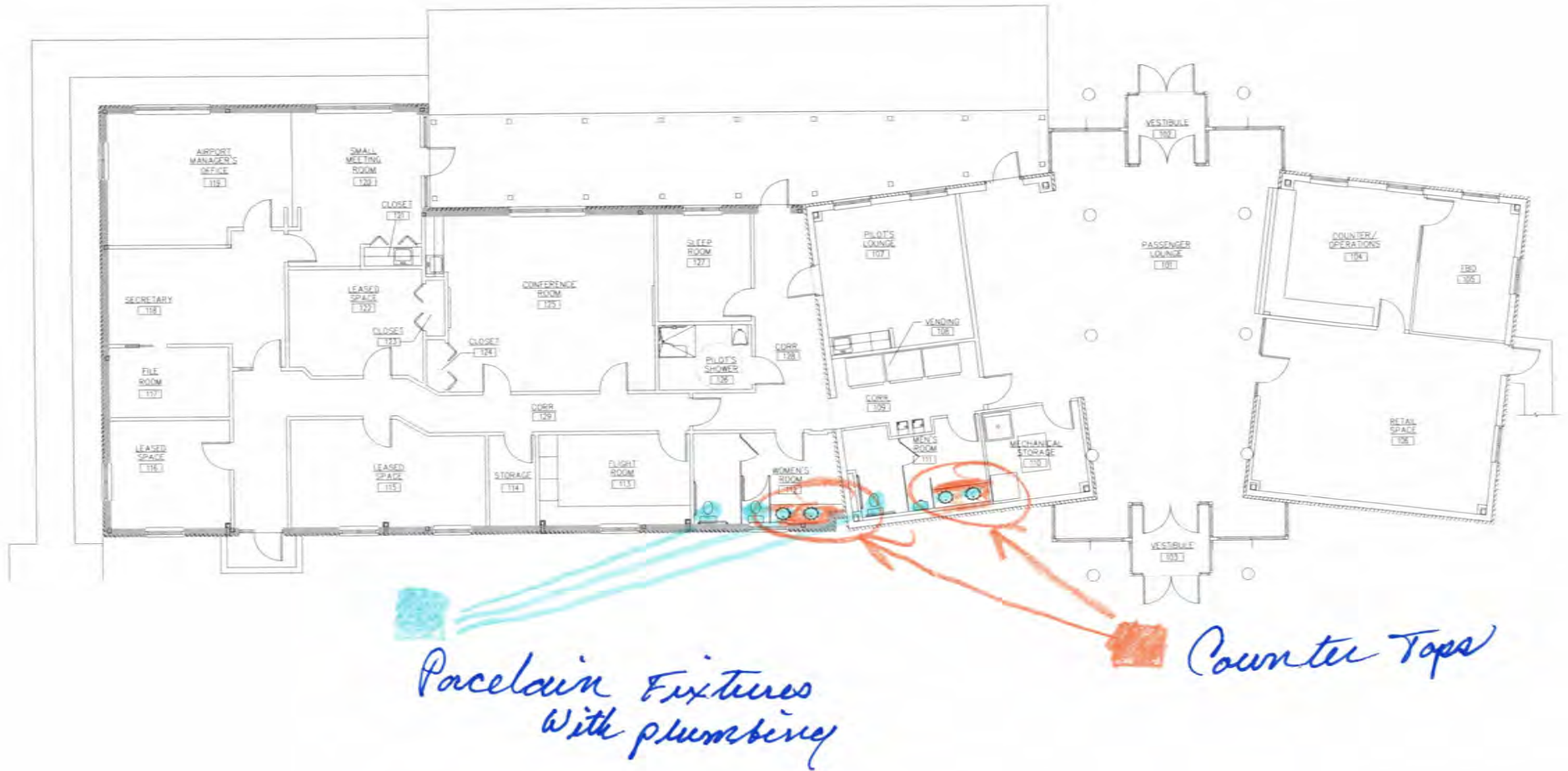

COMMONWEALTH AVIATION FUND
FUNDING REQUEST SUMMARY
VAB DATE: 06/09/2021

Airport: Hampton Roads Executive Airport
Region: 7
Name: Ms. Vanessa Christie

Sponsor: Virginia Aviation Associates, LLC
Contact: Mr. Steven Fox , Sponsor
Phone: 757-373-3151

State Funding Summary		
	Requested	Recommended
Entitlement	\$0.00	\$0.00
Air Carrier/Reliever Discretionary	\$10,990.00	\$0.00
General Aviation Discretionary	\$0.00	\$5,400.00
TOTALS	\$10,990.00	\$5,400.00

Unmitigated Obstructions

Based Aircraft:	157
Annual Operations:	71,736
Service Role:	RL

Development Program Projects									
Projects			Requested Funding			Recommended Funding			
Description	Priority	Project Cost	Federal	State	Local	Federal	State	Local	
Entrance Sign Replacement (Construction)	165	\$6,988.10		\$5,590.00	\$1,398.10		\$0.00	\$6,988.10	
T-Hangar Taxilane Repair (Construction)	184	\$6,750.00		\$5,400.00	\$1,350.00		\$5,400.00	\$1,350.00	
TOTALS		\$13,738.10	\$0.00	\$10,990.00	\$2,748.10	\$0.00	\$5,400.00	\$8,338.10	

Remarks: Entrance Sign Replacement (Construction)

Staff recommends disapproval.

The existing DOAV-funded entrance sign was damaged by a truck. The Sponsor should investigate insurance coverage for repair costs.

T-Hangar Taxilane Repair (Construction)

Staff recommends approval.

Project: Main Entrance Sign Replacement

Narrative

The existing main entrance sign at KPVG is quite damaged and requires replacement. The new sign will be in the same location. The proposal is attached including specifics of the new sign.

Sketch

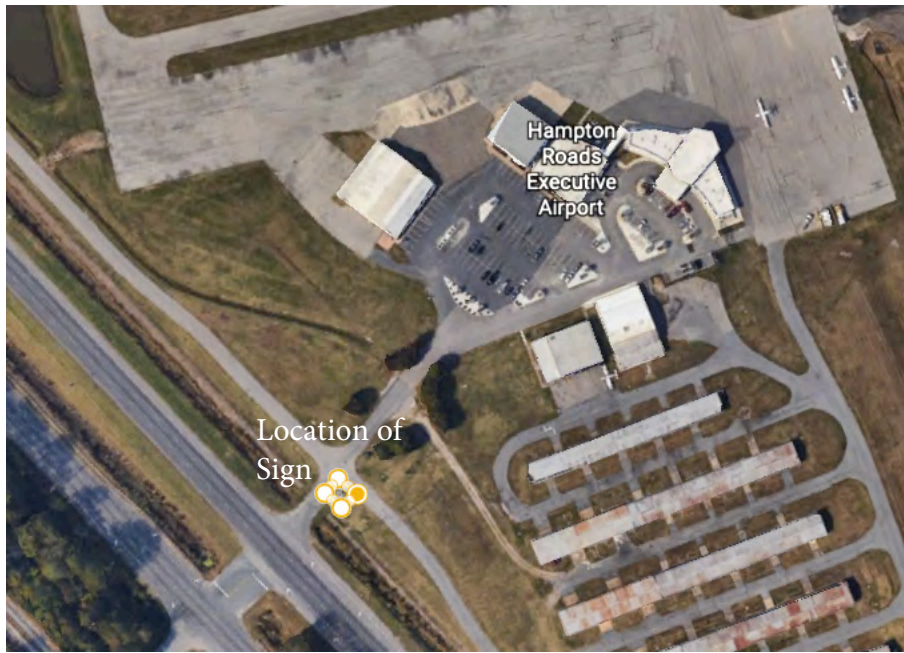
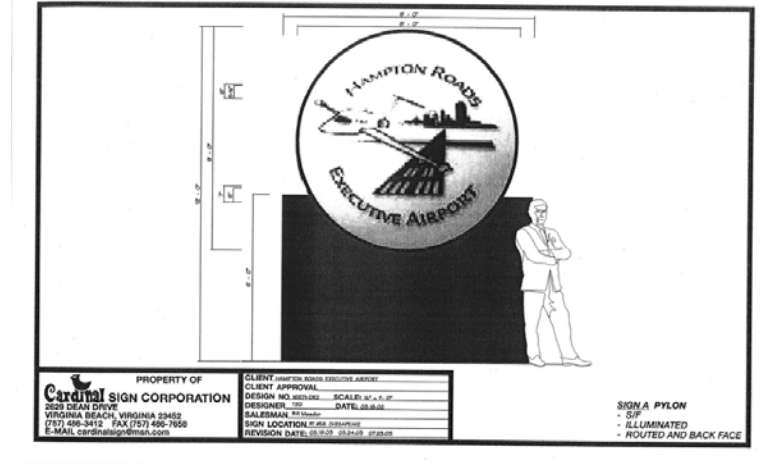

Project: Row 23/24 Asphalt Repairs

Narrative

The asphalt on the taxiway between hangar rows 23 and 24 has deteriorated and needs repair. The attached pictures are provided to display the condition of the asphalt deterioration. Specifics of the repair needed are included below:

Between Hangers: 24 & 23

1 Asphalt Patching approx. 85 sy

Mill areas to a depth of 2" - remove milled material from site
Furnish & place 2" - SM-9.5A asphalt

2 CRACK FILL--- 1500 lf

Clean cracks of all grass and debris and blow with commercial blowers.
Heat crack fill to 400 degrees F.
Distribute hot crack fill throughout cracks 1/4" and larger.

Total 1 & 2

Sketch



COMMONWEALTH AVIATION FUND
 FUNDING REQUEST SUMMARY
 VAB DATE: 06/09/2021

Airport: Hummel Field
 Region: 7
 Name: Ms. Vanessa Christie

Sponsor: County of Middlesex
 Contact: Mr. Matt Walker , County Administrator
 Phone: 804-758-4330

State Funding Summary		
	Requested	Recommended
Entitlement	\$0.00	\$0.00
Air Carrier/Reliever Discretionary	\$0.00	\$0.00
General Aviation Discretionary	\$31,920.00	\$0.00
TOTALS	\$31,920.00	\$0.00

Unmitigated Obstructions

Based Aircraft:	26
Annual Operations:	12,838
Service Role:	LO

Development Program Projects									
Description	Priority	Project Cost	Federal	Requested Funding			Recommended Funding		
				State	Local	Federal	State	Local	
Environmental Impact Report	70	\$39,900.00		\$31,920.00	\$7,980.00		\$0.00	\$39,900.00	
TOTALS		\$39,900.00	\$0.00	\$31,920.00	\$7,980.00	\$0.00	\$0.00	\$39,900.00	

Remarks: Environmental Impact Report
 Staff recommends disapproval.
 An Airport Layout Plan has not been completed.

Matthew L. Walker
County Administrator



Betty S. Muncy
Assistant County Administrator

County of Middlesex
Office of the County Administrator

PROJECT NARRATIVE

**Hummel Field – W75
Environmental Impact Review**

The Environmental Impact Review will be used to evaluate the proposed alternatives for runway improvements at Hummel Field, including runway realignment and lengthening. Environmental documentation will be prepared in accordance with the National Environmental Policy Act (NEPA) and the Code of Virginia with a goal of receiving a positive determination from the Department of Environmental Quality, as well as identification of a runway alternative that will provide public benefit while avoiding/minimizing environmental impacts.

Analysis of data will be performed for specific environmental categories as required by the Virginia Department of Environmental Quality's Environmental Impact Review Manual and *Virginia Code*, Section 5.1-7. The EIR documentation will be concise and will include support documents, as appropriate.

Hummel Field



COMMONWEALTH AVIATION FUND
 FUNDING REQUEST SUMMARY
 VAB DATE: 06/09/2021

Airport: Middle Peninsula Regional Airport
 Region: 7
 Name: Ms. Vanessa Christie

Sponsor: Middle Peninsula Regional Airport Authority
 Contact: Mr. Bill Dale , Manager
 Phone: 804-785-9725

State Funding Summary		
	Requested	Recommended
Entitlement	\$0.00	\$0.00
Air Carrier/Reliever Discretionary	\$0.00	\$0.00
General Aviation Discretionary	\$31,360.00	\$12,160.00
TOTALS	\$31,360.00	\$12,160.00

Unmitigated Obstructions

Based Aircraft:	37
Annual Operations:	15,343
Service Role:	GR

Development Program Projects									
Projects			Requested Funding			Recommended Funding			
Description	Priority	Project Cost	Federal	State	Local	Federal	State	Local	
Access Road & Box Hangar Site (Environmental)	110	\$24,000.00		\$19,200.00	\$4,800.00		\$0.00	\$24,000.00	
Rotating Beacon Replacement (Construction)	162	\$15,200.00		\$12,160.00	\$3,040.00		\$12,160.00	\$3,040.00	
TOTALS		\$39,200.00	\$0.00	\$31,360.00	\$7,840.00	\$0.00	\$12,160.00	\$27,040.00	

Remarks: Access Road & Box Hangar Site (Environmental)

Staff recommends disapproval.

Staff is requesting additional information on the demand for the nine proposed hangars, a schedule of hangar completion, and information on the developer(s).

Rotating Beacon Replacement (Construction)

Staff recommends approval.

**AIRPORT CAPITAL IMPROVEMENT PROGRAM
PROGRAM NARRATIVE
MIDDLE PENINSULA REGIONAL AIRPORT (FYJ)**

The following program narrative addresses the detailed project description and justification for the current year of the Airport Capital Improvement Program.

1 Box Hangar Site (Environmental)

This project includes the environmental coordination for the preparation of a Federal Aviation Administration (FAA) required Categorical Exclusion (CatEx) package for the construction of nine box hangars and associated facilities including parking lots and access road at the Middle Peninsula Regional Airport (FYJ). Also included is the coordination with the Virginia Department of Environmental Quality (DEQ) for the Coastal Zone Management Program (CZMP) and the Virginia Department of Historic Resources (DHR) for the Section 106 review. The parcels of airport property will be leased to private entities for the development of these hangars. All work will be conducted on airport property.

The project budget includes a Sponsor Administrative Cost allowance for incidental items that may be incurred.

Estimated Cost:	State (80%):	\$19,200
	Local (20%):	\$4,800

2 Rotating Beacon - LED

This existing rotating beacon has not been functioned properly and requires frequent service. Because of the age of the beacon, it's getting difficult to find parts and parts and maintenance are becoming more expensive. The airport's NAVAIDs and lighting consultant has recommended that the unit be replaced with a new LED beacon. The new beacon will be more energy efficient and less costly to operate.

Estimated Cost:	State (80%):	\$12,160
	Local (20%):	\$3,040

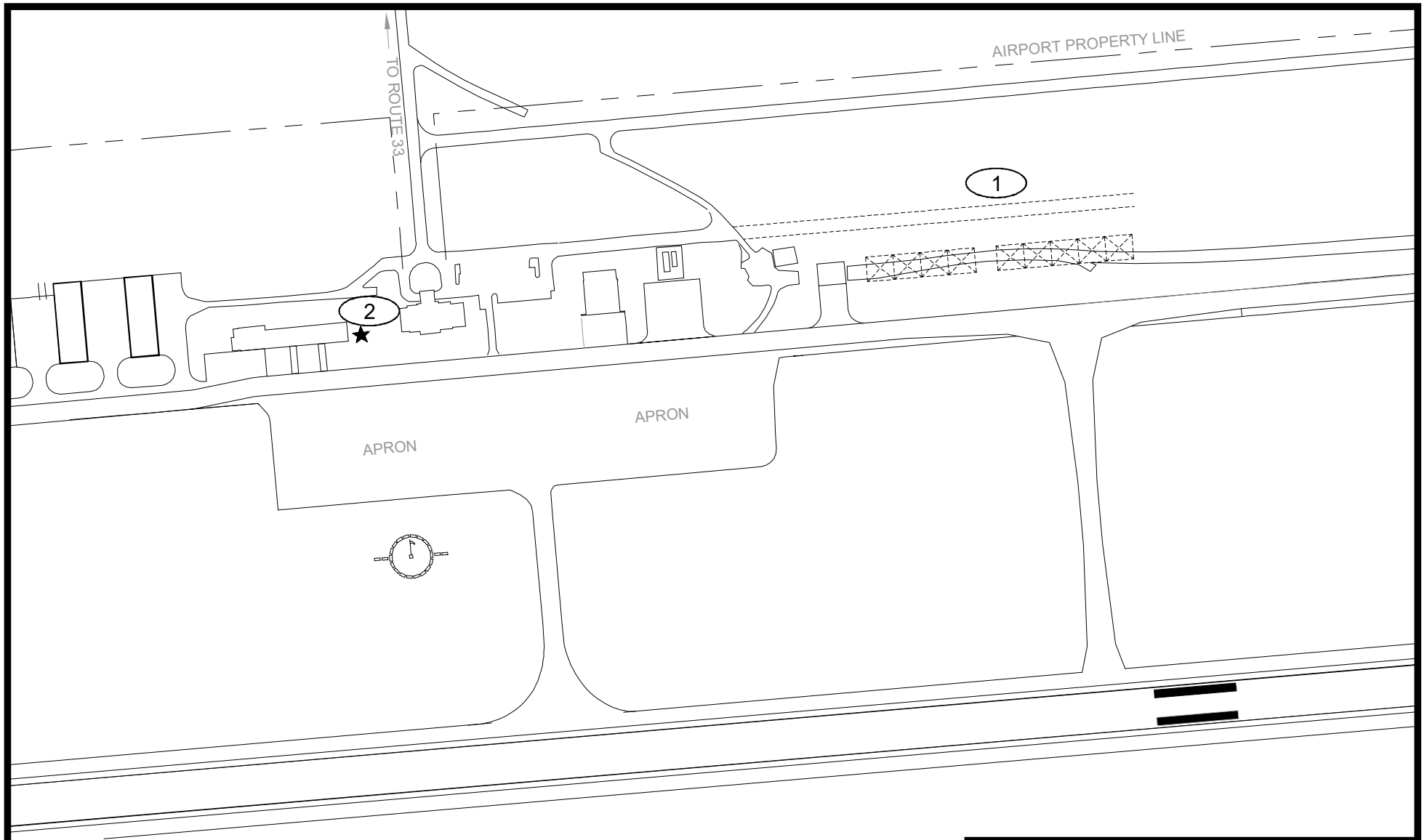

- ① ACCESS ROAD & BOX HANGAR SITE (ENVIRONMENTAL)
- ② ROTATING BEACON - LED REPLACEMENT

ACIP SKETCH
MIDDLE PENINSULA REGIONAL AIRPORT
TALBERT & BRIGHT ENGINEERING & PLANNING CONSULTANTS 10105 KRAUSE ROAD, SUITE 100 CHESTERFIELD, VIRGINIA 23832 PHONE: 804-768-6878 FAX: 804-768-6871